

LM2068E-1

LCD Module User Manual

Shenzhen TOPWAY Technology Co., Ltd.

Rev.	Descriptions	Release Date
0.1	Preliminary, new release	2007-05-28
0.2	Update Top, Tst	2007-10-24

Table of Content

1. Basic Specifications	3
1.1 Display Specifications.....	3
1.2 Mechanical Specifications	3
1.3 Block Diagram	3
1.4 Terminal Functions	4
2. Absolute Maximum Ratings	5
3. Electrical Characteristics	5
3.1 DC Characteristics	5
3.2 LED Backlight Circuit Characteristics	5
3.3 AC Characteristics	6
3.4 Reset Timing.....	7
4. Function Specifications	8
4.1 Adjusting the Display Contrast	8
4.2 Resetting the LCD module.....	8
4.3 Jumper Functions	8
4.4 Display Pixel Map	8
4.5 Command Summary.....	9
4.6 Initialization Setting Example.....	10
5. Design and Handling Precaution	11

1. Basic Specifications

1.1 Display Specifications

- 1) LCD Display Mode : FSTN, Positive, Transflective
- 2) Display Color : Display Data = "1" : Dark Gray (*1)
: Display Data = "0" : Light Gray (*2)
- 3) Viewing Angle : 9 H
- 4) Driving Method : 1/240 duty, 1/12 bias
- 5) Backlight : White LED backlight

Note:

*1. Color tone may slightly change by Temperature and Driving Condition.

*2. The Color is defined as the inactive / background color

1.2 Mechanical Specifications

- 1) Outline Dimension : 99.5 x 71.1 x 10.0 MAX. (exclude FFC terminal)
see attached Outline Drawing for details

1.3 Block Diagram

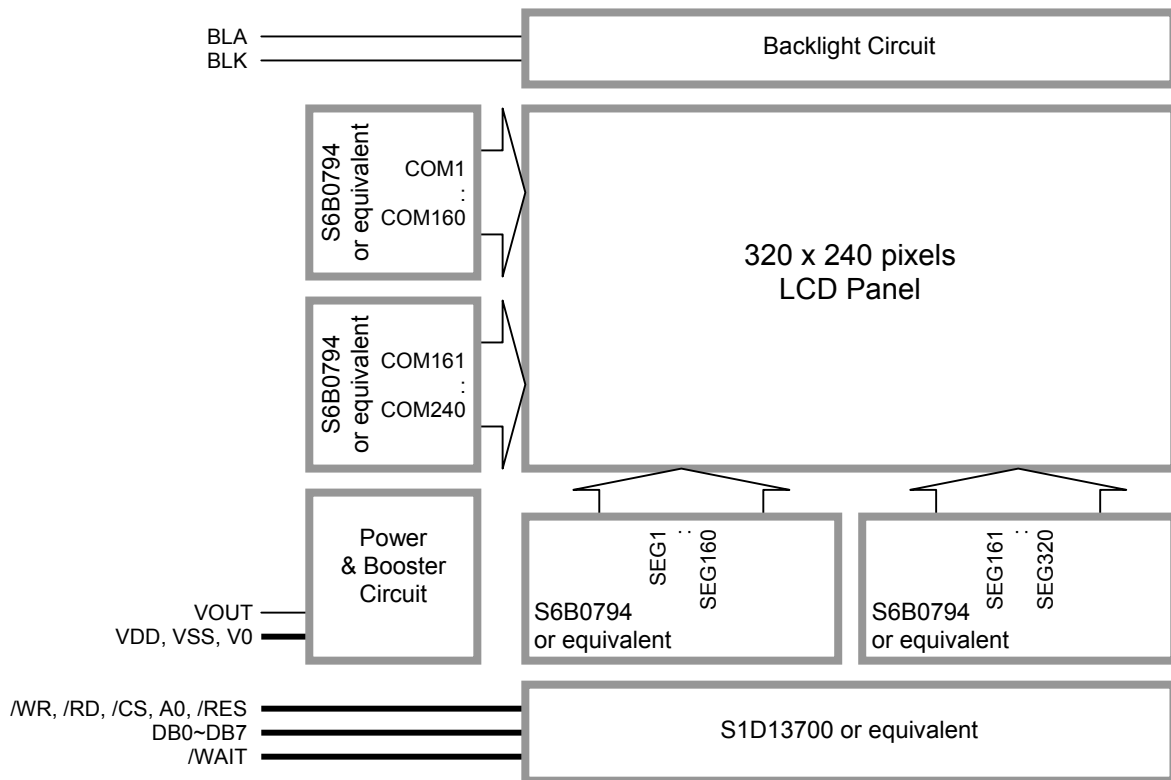

1.4 Terminal Functions

Pin No.	Pin Name	I/O	Descriptions
1	VSS	Power	0V Power Supply, GND
2	VDD	Power	Positive Power Supply
3	V0	Input	LCD Contrast Reference Input
4	/WR	Input	Write enable input, active LOW
5	/RD	Input	Read enable input, active LOW
6	/CS	Input	Chip Select Signal /CS=LOW: Data IO is enabled
7	A0	Input	Data Type Select A0=H: command write, display data or cursor add read A0=L: status flag read, display data or parameter write
8	/RES	Input	Reset Signal: /RES = L, Reset the LCD Module /RES = H, Normal Running
9	DB0	I/O	8-bit bi-directional data bus
:	:		
16	DB7		
17	/WAIT	Output	Wait signal (*1)
18	VOUT	Power	Power Booster Output for V0
19	BLA	Power	Positive Power Supply for LED backlight
20	BLK	Power	Negative Power Supply for LED backlight

note:

- *1. If there is no read write activity, /WAIT will be in HZ state.

2. Absolute Maximum Ratings

Items	Symbol	Min.	Max.	Unit	Condition
Supply Voltage	V_{DD}	0	+7.0	V	$V_{SS} = 0V$
Input Voltage	V_{IN}	$V_{SS}-0.3$	$V_{DD}+0.3$	V	$V_{SS} = 0V$
Operating Temperature	T_{OP}	-20	+70	°C	No Condensation
Storage Temperature	T_{ST}	-30	+80	°C	No Condensation

Cautions:

Any Stresses exceeding the Absolute Maximum Ratings may cause substantial damage to the device. Functional operation of this device at other conditions beyond those listed in the specification is not implied and prolonged exposure to extreme conditions may affect device reliability.

3. Electrical Characteristics

3.1 DC Characteristics

$V_{SS}=0V, V_{DD}=3.3V, T_{OP}=25^{\circ}C$

Items	Symbol	MIN.	TYP.	MAX.	Unit	Applicable Pin
Operating Voltage	V_{DD}	3.0	3.3	3.6	V	VDD
Input High Voltage	V_{IN}	$0.8 \times V_{DD}$	-	VDD	V	DB0~DB7, /WR, /RD, /CS, A0, /RES
Input Low Voltage	V_{IN}	VSS	-	$0.15 \times V_{DD}$	V	DB0~DB7, /WR, /RD, /CS, A0, /RES
LCD Contrast Reference Voltage (*1)	V_0	-	15.9	-	V	V0
Frame Freq.	f_{FRAME}	60	66	80	Hz	
Operating Current	I_{DD}	-	24.0	62.0	mA	VDD

Note:

*1. Frame freq. at 66Hz

3.2 LED Backlight Circuit Characteristics

$BLK=0V, I_{f_{BLA}}=100.0mA, T_{OP}=25^{\circ}C$

Items	Symbol	MIN.	TYP.	MAX.	Unit	Applicable Pin
Forward Voltage	$V_{f_{BLA}}$	-	3.3	-	V	BLA
Forward Current	$I_{f_{BLA}}$	-	100	130	mA	BLA

Cautions:

Exceeding the recommended driving current could cause substantial damage to the backlight and shorten its lifetime.

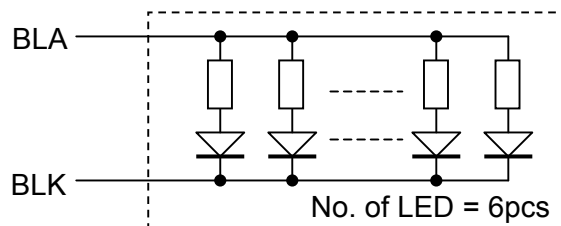

3.3 AC Characteristics

3.3.1 8080 Mode

$V_{SS}=0V, V_{DD}=3.3V, T_{OP}=25^{\circ}C$

Item	Symbol	MIN.	TYP.	MAX.	Unit
/CS setup time	t1	7	-	-	ns
A0 setup time	t2	7	-	-	ns
/WR, /RD falling edge to /WAIT driven low	t3	1.6	-	20	ns
D[7:0] setup time to /WR rising edge (write cycle)	t4	(*2)	-	-	ns
/RD falling edge to D[7:0] driven (read cycle)	t5	4	-	-	ns
/CS hold time	t6	9	-	-	ns
A0 hold time	t7	9	-	-	ns
/RD, /WR rising edge to WAIT# high impedance	t8	1.6	-	13	ns
D[7:0] hold time from /WR rising edge (write cycle)	t9	6.5	-	-	ns
D[7:0] hold time from /CS rising edge (read cycle)	t10	2.4	-	18	ns
/WAIT rising edge to valid Data	t11	-	-	(*3)	ns
/RD, /WR pulse inactive time	t12	(*4)	-	-	ns
/WAIT pulse active time	t13	-	-	(*5)	ns

Note:

- *1. T_s = System clock period
- *2. t_{4min} = $2T_s + 5$
- *3. t_{11max} = $1T_s + 5$ (for 3.3V)
- *4. t_{12min} = $1T_s$ (for a read cycle followed by a read or write cycle)
 = $2T_s + 2$ (for a write cycle followed by a write cycle)
 = $5T_s + 2$ (for a write cycle followed by a read cycle)
- *5. t_{13max} = $4T_s + 2$
- *6. Input signal rise/fall time should be less than 4.5ns
- *7. for details, please see the S1D13700 data sheet

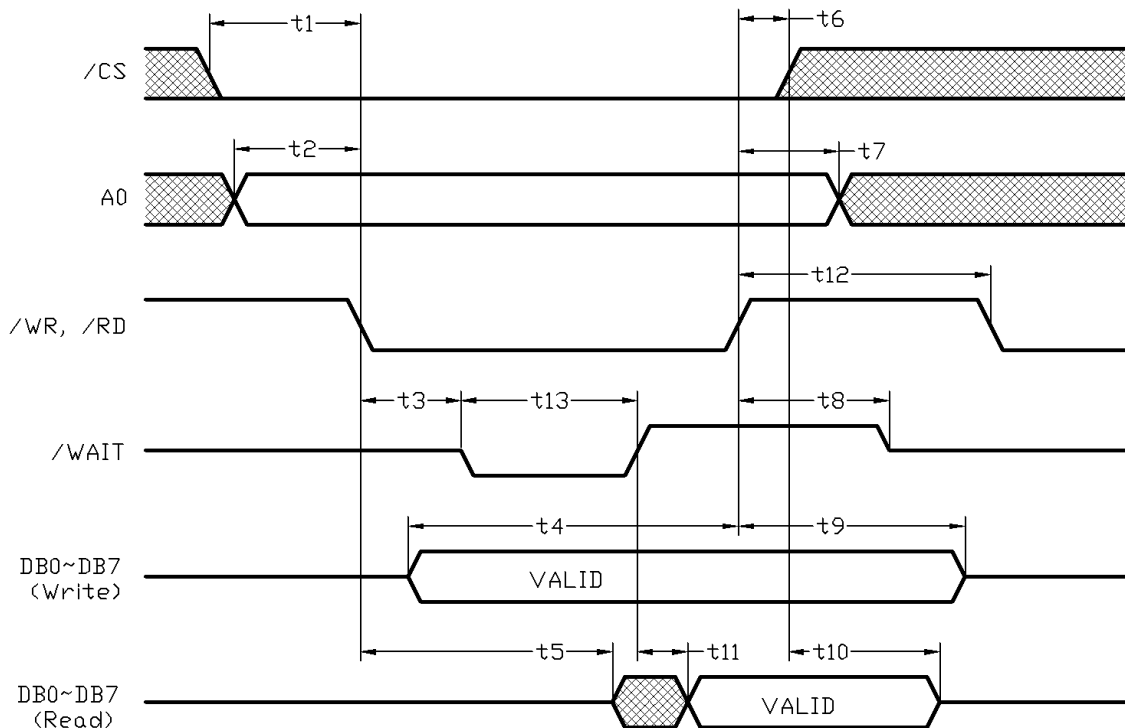

Bus Timing Diagram

3.4 Reset Timing

$V_{SS}=0V, V_{DD}=3.3V, T_{OP}=25^{\circ}C$

Item	Symbol	MIN.	TYP.	MAX.	Unit
Oscillator Stable Delay (*1)	t1	4.0	-	-	ms
Reset Pulse Duration (*2)	t2	1.3	-	-	ms

note:

- *1. A delay is required after exiting power save mode. Writing the SYSTEM SET command will exit power save mode and start the internal oscillator.
- *2. It requires a reset pulse after power-on in order to re-initialize its internal state.

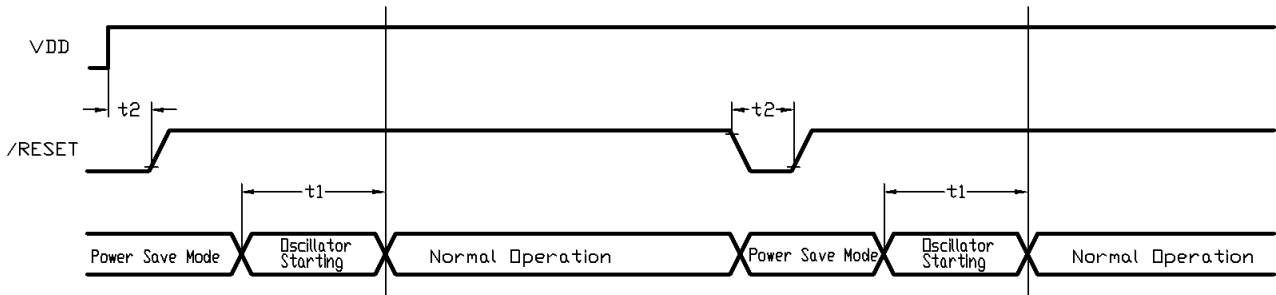

Reset Timing Diagram

4. Function Specifications

4.1 Adjusting the Display Contrast

A Variable-Resistor must be connected to the LCD module for providing a reference to V0. Adjusting the VR will result the change of LCD display contrast.

The recommended value of VR is 25k to 50k

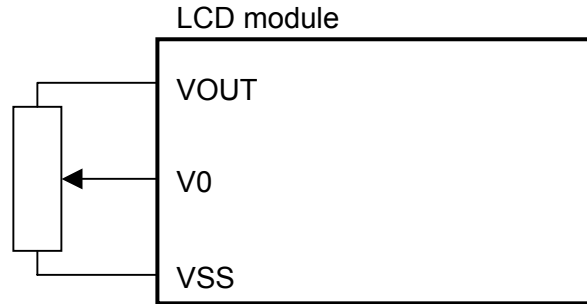

4.2 Resetting the LCD module

The LCD module should be initialized by hardware reset, using /RES terminal.

4.3 Jumper Functions

4.3.1 Interfacing Setting

Jumper		Function Description
JP3	JP6	
Open	Close	CNF3=L, 8080 mode selected <default>
Close	Open	CNF3=H, 6800 mode selected

4.3.2 Clock Divider Setting

Jumper				Function Description
JP1	JP2	JP4	JP5	
Open	Open	Close	Close	1/4 clock divider <default>
Close	Open	Open	Close	1/8 clock divider
Open	Close	Close	Open	1/16 clock divider

4.4 Display Pixel Map

1,1 (D7)	2,1 (D6)	3,1 (D5)	4,1 (D4)	5,1 (D3)	---	---	316,1 (D4)	317,1 (D3)	318,1 (D2)	319,1 (D1)	320,1 (D0)
1,2 (D7)	2,2 (D6)	3,2 (D5)	4,2 (D4)	5,2 (D3)	---	---	316,2 (D4)	317,2 (D3)	318,2 (D2)	319,2 (D1)	320,2 (D0)
1,3 (D7)	2,3 (D6)	3,3 (D5)	4,3 (D4)	5,3 (D3)	---	---	316,3 (D4)	317,3 (D3)	318,3 (D2)	319,3 (D1)	320,3 (D0)
:	:	:	:	:	:	:	:	:	:	:	:
:	:	:	:	:	:	:	:	:	:	:	:
:	:	:	:	:	:	:	:	:	:	:	:
1,238 (D7)	2,238 (D6)	3,238 (D5)	4,238 (D4)	5,238 (D3)	---	---	316,238 (D4)	317,238 (D3)	318,238 (D2)	319,238 (D1)	320,238 (D0)
1,239 (D7)	2,239 (D6)	3,239 (D5)	4,239 (D4)	5,239 (D3)	---	---	316,239 (D4)	317,239 (D3)	318,239 (D2)	319,239 (D1)	320,239 (D0)
1,240 (D7)	2,240 (D6)	3,240 (D5)	4,240 (D4)	5,240 (D3)	---	---	316,240 (D4)	317,240 (D3)	318,240 (D2)	319,240 (D1)	320,240 (D0)

Pixel mapping (Top View)

Note:

- *1. Based on the top view of the LCD module, the 1, 1 (x, y) pixel is the upper-left pixel; the 320, 240 (x, y) pixel is the lower-right pixel.
- *2. For the details of memory mapping please refer to S1D13700 datasheet.

4.5 Command Summary

Command	Parameter	A0	/RD	/WR	D7	D6	D5	D4	D3	D2	D1	D0	HEX	Descriptions
SYSTEM SET	-	1	1	0	0	1	0	0	0	0	0	0	40	Init device and display (with 8 parameters)
	P1	0	1	0	0	0	IV	1	W/S	M2	0	M0	**	M0=0: internal CG ROM M0=1: internal CG RAM M2=0: 8-pixel char height M2=1: 16-pixel char height W/S=0: single panel drive W/S=1: dual panel drive IV=0: Screen top-line correction IV=1: No screen top-line correction
	P2	0	1	0	MOD	0	0	0	FX			**	FX=Horizontal Char Size in pixels – 1 (define the horizontal char size) MOD=0: 16-line AC drive MOD=1: two frame AC drive	
	P3	0	1	0	0	0	0	0	FY			**	FY=Vertical Char Size in pixels – 1 (define the vertical char size)	
	P4	0	1	0	C/R								**	C/R: Character Bytes per Row
	P5	0	1	0	TC/R								**	TC/R: Total Char Bytes per Row (including horizontal blanking)
	P6	0	1	0	L/F								**	L/F: Lines per Frame
	P7	0	1	0	APL								**	APL: Horizontal address range of the virtual screen (low byte)
	P8	0	1	0	APH								**	APH: Horizontal address range of the virtual screen (high byte)
POWER SAVE	-	1	1	0	0	1	0	1	0	0	1	1	53	Power Save Mode Enable
DISP ON/OFF	-	1	1	0	0	1	0	1	1	0	0	D	58 / 59	Enable and disable display and display flashing (with 1 parameter) D=0: Display OFF D=1: Display ON
	P1	0	1	0	FP5	FP4	FP3	FP2	FP1	FP0	FC1	FC0	**	Each pair of bit in FP sets the attributes of one screen block
SCROLL	-	1	1	0	0	1	0	0	0	1	0	0	44	Set display start address and display regions (with 8 or 10 parameters)
	P1	0	1	0	A7	A6	A5	A4	A3	A2	A1	A0	**	Screen Block 1 Start Address (SAD1) LSB
	P2	0	1	0	A15	A14	A13	A12	A11	A10	A9	A8	**	Screen Block 1 Start Address (SAD1) MSB
	P3	0	1	0	L7	L6	L5	L4	L3	L2	L1	L0	**	Screen Block 1 Size Register (SL1)
	P4	0	1	0	A7	A6	A5	A4	A3	A2	A1	A0	**	Screen Block 2 Start Address (SAD2) LSB
	P5	0	1	0	A15	A14	A13	A12	A11	A10	A9	A8	**	Screen Block 2 Start Address (SAD2) MSB
	P6	0	1	0	L7	L6	L5	L4	L3	L2	L1	L0	**	Screen Block 2 Size Register (SL2)
	P7	0	1	0	A7	A6	A5	A4	A3	A2	A1	A0	**	Screen Block 3 Start Address (SAD3) LSB
	P8	0	1	0	A15	A14	A13	A12	A11	A10	A9	A8	**	Screen Block 3 Start Address (SAD3) MSB
	P9	0	1	0	A7	A6	A5	A4	A3	A2	A1	A0	**	Screen Block 4 Start Address (SAD4) LSB (for dual panel drive and two layer config are select)
P10	0	1	0	A15	A14	A13	A12	A11	A10	A9	A8	**	Screen Block 4 Start Address (SAD4) MSB (for dual panel drive and two layer config are select)	
CSRFORM	-	1	1	0	0	1	0	1	1	1	0	1	5D	Set cursor type (with 2 parameters)
	P1	0	1	0	0	0	0	0	X3	X2	X1	X0	**	CRX
	P2	0	1	0	CM	0	0	0	Y3	Y2	Y1	Y0	**	CRY CM=0: underscore cursor; CM=1: block cursor
CSRDIR	-	1	1	0	0	1	0	0	1	1	CD1	CD0	4C~4F	Set Direction of Cursor movement CD=00: Right; CD=01: Left; CD=10: Up; CD=11: Down
OVLAY	-	1	1	0	0	1	0	1	1	0	1	1	5B	Set display overlay format (with 1 parameters)
	P1	0	1	0	0	0	0	OV	DM2	DM1	MX1	MX0	**	
CGRAM ADR	-	1	1	0	0	1	0	1	1	1	0	0	5C	Set Start address of char generator RAM (with 2 parameters)
	P1	0	1	0	A7	A6	A5	A4	A3	A2	A1	A0	**	SAGL
	P2	0	1	0	A15	A14	A13	A12	A11	A10	A9	A8	**	SAGH
HDOT SCR	-	1	1	0	0	1	0	1	1	0	1	0	5A	Set horizontal scroll position (with 1 parameters)
	P1	0	1	0	0	0	0	0	0	D2	D1	D0	**	
CSRW	-	1	1	0	0	1	0	0	0	1	1	0	46	Set cursor address (with 2 parameters)
	P1	0	1	0	A7	A6	A5	A4	A3	A2	A1	A0	**	CSRL
	P2	0	1	0	A15	A14	A13	A12	A11	A10	A9	A8	**	CSRH
CSRR	-	1	1	0	0	1	0	0	0	1	1	1	47	Read Cursor Address (with 2 parameters)
	P1	1	0	1	A7	A6	A5	A4	A3	A2	A1	A0	**	CSRL
	P2	1	0	1	A15	A14	A13	A12	A11	A10	A9	A8	**	CSRH
GRAY SCALE	-	1	1	0	0	1	1	0	0	0	0	0	60	select the gray scale depth (in bits-per-pixel)
	P1	0	1	0	0	0	0	0	0	0	BPP1	BPP2	**	BPP=00: 1 bits-per-pixel; BPP=01: 2 bits-per-pixel; BPP=10: 4 bits-per-pixel; BPP=01: reserved
MWRITE	-	1	1	0	0	1	0	0	0	0	1	0	42	Write to display memory (with n parameters)
	P1	0	1	0	Memory Data								**	Display memory data
	:	:	:	:	:								**	
	Pn	0	1	0	Memory Data								**	
MREAD	-	1	1	0	0	1	0	0	0	0	1	1	43	Read from display memory (with n parameters)
	P1	1	0	1	Memory Data								**	Display memory data
	:	:	:	:	:								**	
	Pn	1	0	1	Memory Data								**	

Note:
For details please refer to S1D13700 datasheet.

4.6 Initialization Setting Example

The following setting should be issue to LCD module after hardware reset.
(example could be adjusted if necessary.)

Command	Parameter	A0	/RD	/WR	Value (binary)	HEX	Descriptions
SYSTEM SET	-	1	1	0	0100 0000	40	Init device and display (with 8 parameters)
	P1	0	1	0	0011 0000	30	M0=0: internal CG ROM M2=0: 8-pixel char height W/S=0: single panel drive IV=1: No screen top-line correction
	P2	0	1	0	1000 0111	87	FX=7: the horizontal char size=7+1=8 WF=1: two frame AC drive
	P3	0	1	0	0000 0111	07	FY=7: the vertical char size=7+1=8
	P4	0	1	0	0010 1000	28	C/R: Character Bytes per Row
	P5	0	1	0	0100 1001	47	TC/R: Total Char Bytes per Row (including horizontal blanking)
	P6	0	1	0	1110 1111	EF	L/F: Lines per Frame
	P7	0	1	0	0010 1000	28	APL: Horizontal address range of the virtual screen (low byte)
P8	0	1	0	0000 0000	00	APH: Horizontal address range of the virtual screen (high byte)	
DISP ON/OFF	-	1	1	0	0101 1001	59	Display ON
	P1	0	1	0	0000 0100	04	sets the attributes of screen block (SAD1 on, cursor off)
SCROLL	-	1	1	0	0100 0100	44	Set cursor type (with 10 parameters)
	P1	0	1	0	0000 0000	00	SAD 1L
	P2	0	1	0	0000 0000	00	SAD 1H
	P3	0	1	0	1110 1111	EF	SL1
	P4	0	1	0	0000 0000	00	SAD 2L (not assigned in this example)
	P5	0	1	0	0000 0000	00	SAD 2H (not assigned in this example)
	P6	0	1	0	1110 1111	EF	SL2
	P7	0	1	0	0000 0000	00	SAD3L (not assigned in this example)
P8	0	1	0	0000 0000	00	SAD3H (not assigned in this example)	
CSRFORM	-	1	1	0	0101 1101	5D	Set cursor type (with 2 parameters)
	P1	0	1	0	0000 0111	07	CRX
	P2	0	1	0	0001 0111	17	CRY
CSRDIR	-	1	1	0	0100 1100	4C	Set Direction of Cursor movement
OVLAY	-	1	1	0	0101 1011	5B	Set display overlay format (with 1 parameters)
	P1	0	1	0	0000 0101	05	OV=0: two layer in used; DM1=0: layer 3 as text mode; DM0=1: layer 1 as graphic mode; MX=01: layer1 XOR Layer 2
HDOT SCR	-	1	1	0	0101 1010	5A	Set horizontal scroll position (with 1 parameters)
	P1	0	1	0	0000 0000	00	no scroll
GRAY SCALE	-	1	1	0	0110 0000	60	sel select the gray scale depth (in bits-per-pixel)
	P1	0	1	0	0000 0000	00	BPP=00: 1 bits-per-pixel
CSRW	-	1	1	0	0100 0110	46	Set cursor address (with 2 parameters)
	P1	0	1	0	0000 0000	00	CSRL
	P2	0	1	0	0000 0000	00	CSRH
MWRITE	-	1	1	0	0100 0010	42	Write to display memory (with n parameters)
	P1	0	1	0	Memory Data	**	Display memory data
	:	:	:	:	:	**	
	Pn	0	1	0	Memory Data	**	

Note:
For details please refer to S1D13700 datasheet.

5. Design and Handling Precaution

1. The LCD panel is made by glass. Any mechanical shock (eg. dropping from high place) will damage the LCD module.
2. Do not add excessive force on the surface of the display, which may cause the Display color change abnormally.
3. The polarizer on the LCD is easily get scratched. If possible, do not remove the LCD protective film until the last step of installation.
4. Never attempt to disassemble or rework the LCD module.
5. Only Clean the LCD with Isopropyl Alcohol or Ethyl Alcohol. Other solvents (eg. water) may damage the LCD.
6. When mounting the LCD module, make sure that it is free from twisting, warping and distortion.
7. Ensure to provide enough space (with cushion) between case and LCD panel to prevent external force adding on it, or it may cause damage to the LCD or degrade the display result.
8. Only hold the LCD module by its side. Never hold LCD module by add force on the heat seal or TAB.
9. Never add force to component of the LCD module. It may cause invisible damage or degrade of the reliability.
10. LCD module could be easily damaged by static electricity. Be careful to maintain an optimum anti-static work environment to protect the LCD module.
11. When peeling off the protective film from LCD, static charge may cause abnormal display pattern. It is normal and will resume to normal in a short while.
12. Take care and prevent get hurt by the LCD panel sharp edge.
13. Never operate the LCD module exceed the absolute maximum ratings.
14. Keep the signal line as short as possible to prevent noisy signal applying to LCD module.
15. Never apply signal to the LCD module without power supply.
16. IC chip (eg. TAB or COG) is sensitive to the light. Strong lighting environment could possibly cause malfunction. Light sealing structure casing is recommend.
17. LCD module reliability may be reduced by temperature shock.
18. When storing the LCD module, avoid exposure to the direct sunlight, high humidity, high temperature or low temperature. They may damage or degrade the LCD module