

# LM24064DDC

## LCD Module User Manual

Shenzhen TOPWAY Technology Co., Ltd.

Rev.	Descriptions	Release Date
0.1	New release	2004-11-19
0.2	Revise section "4.3 Internal Hard-wired Setting" MD3, MD2, MD1, MD0 & MDS	2005-06-11

**Table of Content**

<b>1. Basic Specifications</b> .....	<b>3</b>
1.1 Display Specifications .....	3
1.2 Mechanical Specifications .....	3
1.3 Block Diagram .....	3
1.4 Terminal Functions .....	4
<b>2. Absolute Maximum Ratings</b> .....	<b>5</b>
<b>3. Electrical Characteristics</b> .....	<b>5</b>
3.1 DC Characteristics .....	5
3.2 LED Backlight Circuit Characteristics .....	5
3.3 AC Characteristics .....	6
<b>4. Function Specifications</b> .....	<b>7</b>
4.1 Adjusting the Display Contrast .....	7
4.2 Resetting the LCD module .....	7
4.3 Internal Hard-wired Setting .....	7
4.4 Display Memory Mapping Parameter .....	7
4.5 Commands Table .....	8
<b>5. Design and Handling Precaution</b> .....	<b>10</b>

# 1. Basic Specifications

## 1.1 Display Specifications

- 1) LCD Display Mode : STN, Positive, Transflective
- 2) Display Color : Display Data = "1" : Deep Blue (\*1)  
: Display Data = "0" : Light Gray (\*2)
- 3) Viewing Angle : 6 H
- 4) Driving Method : 1/64 duty, 1/9 bias
- 5) Backlight : White LED backlight

Note:

\*1. Color tone may slightly change by Temperature and Driving Condition.

\*2. The Color is defined as the inactive / background color

## 1.2 Mechanical Specifications

- 1) Outline Dimension : 180.0 x 62.0 x 13.8MAX  
see attached Outline Drawing for details

## 1.3 Block Diagram

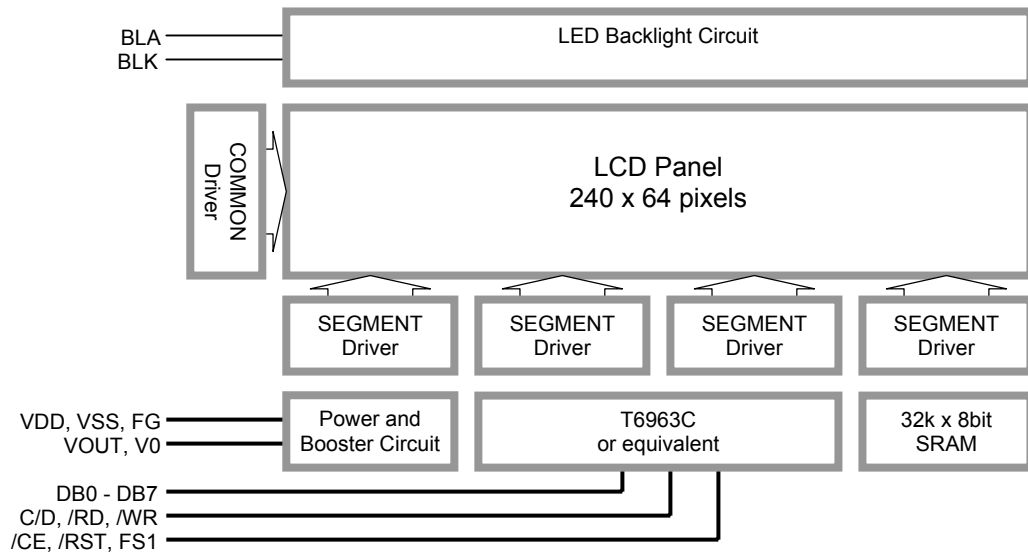

## 1.4 Terminal Functions

Pin No.	Pin Name	I/O	Descriptions
1	FG	Power	Frame Ground, Connected to VSS
2	VSS	Power	0V Power Supply, GND
3	VDD	Power	Positive Power Supply
4	V0	Power	LCD Contrast Reference Input
5	/WR	Input	Data or Command Write Signal
6	/RD	Input	Data or Status Read Signal
7	/CE	Input	Chip Enable Signal
8	C/D	Input	Address for Data or Command: C/D=H, /WR=L, /RD=H : Command Write C/D=H, /WR=H, /RD=L : Status Read C/D=L, /WR=L, /RD=H : Data Write C/D=L, /WR=H, /RD=L : Data Read
9	NC	-	No Connection, Leave Open
10	/RST	Input	Reset Signal: /RST = L, Reset the LCD Module /RST = H, Normal Running
11	DB0	I/O	8-bit data bus
:	:		
18	DB7		
19	FS1	Input	Font Selection Input: FS1=H : 6x8 font FS1=L : 8x8 font
20	VOUT	Power	Power Booster Output for V0
21	BLA	Power	Positive Power Supply for LED backlight
22	BLK	Power	Negative Power Supply for LED backlight

## 2. Absolute Maximum Ratings

Items	Symbol	Min.	Max.	Unit	Condition
Supply Voltage	$V_{DD}$	0	+6.0	V	$V_{SS} = 0V$
Input Voltage	$V_{IN}$	$V_{SS}-0.3$	$V_{DD}+0.3$	V	$V_{SS} = 0V$
Operating Temperature	$T_{OP}$	-20	+70	°C	No Condensation
Storage Temperature	$T_{ST}$	-30	+80	°C	No Condensation

Cautions:

Any Stresses exceeding the Absolute Maximum Ratings may cause substantial damage to the device. Functional operation of this device at other conditions beyond those listed in the specification is not implied and prolonged exposure to extreme conditions may affect device reliability.

## 3. Electrical Characteristics

### 3.1 DC Characteristics

$V_{SS}=0V, V_{DD} =5.0V, T_{OP} =25^{\circ}C$

Items	Symbol	MIN.	TYP.	MAX.	Unit	Applicable Pin
Operating Voltage	$V_{DD}$	4.5	5.0	5.5	V	VDD
Input High Voltage	$V_{IN}$	$0.6 \times V_{DD}$	-	VDD	V	DB0~DB8, /WR, /RD, /CE, C/D, /RST, FS1
Input Low Voltage	$V_{IN}$	0	-	0.6	V	DB0~DB8, /WR, /RD, /CE, C/D, /RST, FS1
Operating Current	$I_{DD}$	-	7.0	20.0	mA	VDD

### 3.2 LED Backlight Circuit Characteristics

$BLK=0V, I_{f_{BLA}}=165mA, T_{OP} =25^{\circ}C$

Items	Symbol	MIN.	TYP.	MAX.	Unit	Applicable Pin
Forward Voltage	$V_{f_{BLA}}$	-	5.0	-	V	BLA
Forward Current	$I_{f_{BLA}}$	-	165	200	mA	BLA

Cautions:

Exceeding the recommended driving current could cause substantial damage to the backlight and shorten its lifetime.

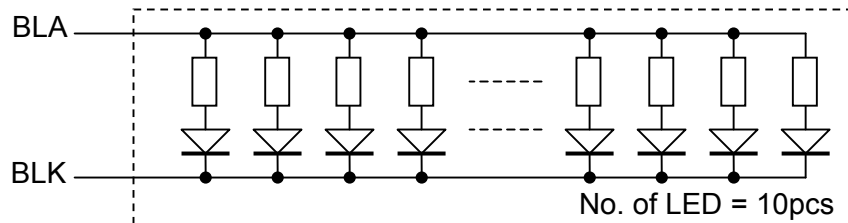

**3.3 AC Characteristics**

$V_{SS}=0V, V_{DD}=5.0V, T_{OP}=25^{\circ}C$

Item	Symbol	MIN.	TYP.	MAX.	Unit
C/D Setup Time	tcds	130	-	-	ns
C/D Hold Time	tcdh	13	-	-	ns
/CE,/RD,/WR Pulse Width	tce, trd, twr	100	-	-	ns
Data Setup Time	tds	100	-	-	ns
Data Hold Time	tdh	50	-	-	ns
Access Time	tacc	-	-	190	ns
Output Hold Time	toh	-	-	65	ns

Note: \*1. Input signal rise/fall time should be less than 20ns

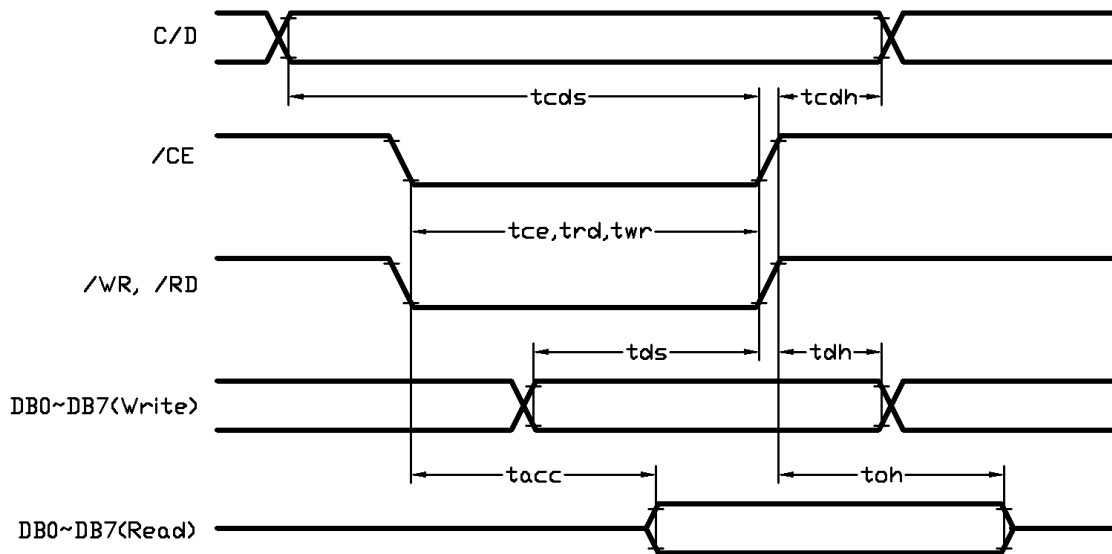

**Bus Timing Diagram**

**3.3.1 Reset Timing**

$V_{SS}=0V, V_{DD}=5.0V, T_{OP}=25^{\circ}C$

Item	Symbol	MIN.	TYP.	MAX.	Unit
Reset Time	tr	-	-	100	$\mu s$
Reset LOW pulse width	trw	100	-	-	$\mu s$

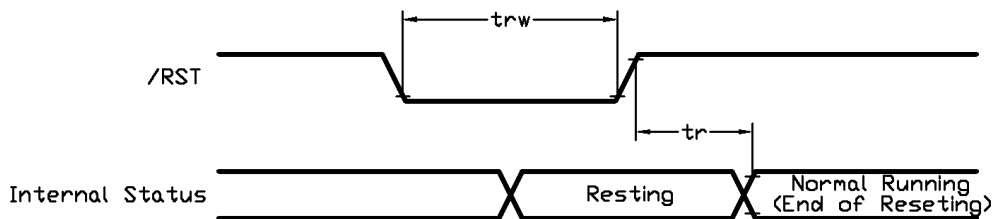

**Reset Timing Diagram**

## 4. Function Specifications

### 4.1 Adjusting the Display Contrast

A Variable-Resistor must be connected to the LCD module for providing a reference to V0. Adjusting the VR will result the change of LCD display contrast. The recommended value of VR is 25k to 50k

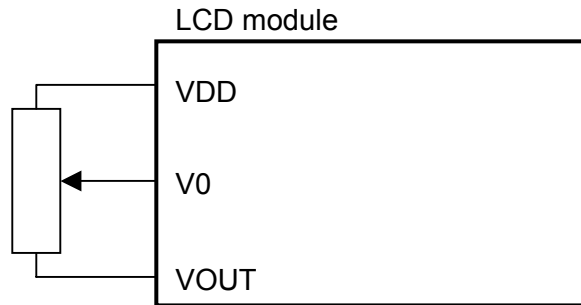

### 4.2 Resetting the LCD module

The LCD module should be initialized by using /RST terminal.

While turning on the VDD and VSS power supply, maintain /RST terminal at LOW level. After the power supply stabilized, release the reset terminal (/RST=HIGH)

### 4.3 Internal Hard-wired Setting

The followings are the major hard-wired setting of the T6963C in side the LCD module.

Items	Value	Wiring Setting	Note
Scanning Type	Single	/DUAL=H	Single scanning LCD
Logical Display Size (x)	320	MD3=H, MD2=L	Logical Display Size is NOT equal Physical Display Size
Logical Display Size (y)	64	MDS=L, MD1=L, MD0=L	
Font size setting	8x8 dot	FS0=L, FS1=L	Font size is depends on FS1 status connected externally
	6x8 dot	FS0=L, FS1=H	

### 4.4 Display Memory Mapping Parameter

Example:

	Home Address	Area
<b>Text Layer</b>	0000(hex)	001E(hex)
<b>Graphics Layer</b>	0800(hex)	001E(hex)

Note:

\*1. For the details of the commands and T6963C operation please refer to T6963C Data sheet.

**4.5 Commands Table**

Command		W/R	R/D	C/D	Code (8bit)	Note
Registers Setting	Set Cursor Pointer	0	1	0	X Address	
		0	1	0	Y Address	
		0	1	1	0010 0001	
	Set Offset Register	0	1	0	DATA	
		0	1	0	0000 0000	
		0	1	1	0010 0010	
	Set Address Pointer	0	1	0	Low Address	
		0	1	0	High Address	
		0	1	1	0010 0100	
Set Control Word	Set Text Home Address	0	1	0	Low Address	
		0	1	0	High Address	
		0	1	1	0100 0000	
	Set Text Area	0	1	0	Columns	
		0	1	0	0000 0000	
		0	1	1	0100 0001	
	Set Graphic Home Address	0	1	0	Low Address	
		0	1	0	High Address	
		0	1	1	0100 0010	
	Set Graphic Area	0	1	0	Columns	
		0	1	0	0000 0000	
		0	1	1	0100 0011	
Mode Set	OR mode	0	1	1	1000 x000	
	EXOR mode	0	1	1	1000 x001	
	AND mode	0	1	1	1000 x011	
	Text Attribute mode	0	1	1	1000 x100	
	Internal CG ROM mode	0	1	1	1000 0xxx	
	External CG RAM mode	0	1	1	1000 1xxx	
Display Mode	Display off	0	1	1	1001 0000	D3: Graphic Display on D2: Text Display on D1: Cursor Display on D0: Cursor Blink on
	Cursor on, Blink off	0	1	1	1001 xx10	
	Cursor on, Blink on	0	1	1	1001 xx11	
	Text on, Graphic off	0	1	1	1001 01xx	
	Text off, Graphic on	0	1	1	1001 10xx	
	Text on, Graphic on	0	1	1	1001 11xx	
Cursor Pattern Select	1-line cursor	0	1	1	1010 0000	
	2-line cursor	0	1	1	1010 0001	
	3-line cursor	0	1	1	1010 0010	
	4-line cursor	0	1	1	1010 0011	
	5-line cursor	0	1	1	1010 0100	
	6-line cursor	0	1	1	1010 0101	
	7-line cursor	0	1	1	1010 0110	
	8-line cursor	0	1	1	1010 0111	
Data Auto Read/Write	Set Data Auto Write	0	1	1	1011 0000	
	Set Data Auto Read	0	1	1	1011 0001	
	Auto Reset	0	1	1	1011 0010	
Data Read/Write	Data Write Increment ADP	0	1	0	Data	
		0	1	1	1100 0000	
	Data Read Increment ADP	0	1	1	1100 0001	
		1	0	0	Data	
	Data Write Decrement ADP	0	1	0	Data	
		0	1	1	1100 0010	
	Data Read Decrement ADP	0	1	1	1100 0011	
		1	0	0	Data	
	Data Write Non-variable ADP	0	1	0	Data	
		0	1	1	1100 0100	
	Data Read Non-variable ADP	0	1	1	1100 0101	
		1	0	0	Data	

**Commands Table (continue)**

Command		/WR	/RD	C/D	Code (8bit)	Note
Screen Peek/Copy	Screen Peek	0	1	1	1110 0000	Not use
	Screen Copy	0	1	1	1110 1000	Not use
Bit Set/Reset	Bit Reset	0	1	1	1111 0xxx	D3: Set/Clear bit D2,D1,D0: bit no.
	Bit Set	0	1	1	1111 1xxx	
	Bit 0 (LSB)	0	1	1	1111 x000	
	Bit 1	0	1	1	1111 x001	
	Bit 2	0	1	1	1111 x010	
	Bit 3	0	1	1	1111 x011	
	Bit 4	0	1	1	1111 x100	
	Bit 5	0	1	1	1111 x101	
	Bit 6	0	1	1	1111 x110	
Bit 7 (MSB)	0	1	1	1111 x111		
Status Check	Check the status	1	0	1	<i>Status</i>	D0: Command execution ready D1: Data read/write ready D2: Auto mode data read ready D3: Auto mode data write ready D4: not used D5: Controller operation normal D6: Error Flag D7: Normal display

Note:

- \*1. When sending commands or data, Status Check must be performed. Otherwise, T6963C cannot operate normally, even after a delay time.
- \*2. For the details of the commands and T6963C operation please refer to T6963C Data sheet.

## 5. Design and Handling Precaution

1. The LCD panel is made by glass. Any mechanical shock (eg. dropping from high place) will damage the LCD module.
2. Do not add excessive force on the surface of the display, which may cause the Display color change abnormally.
3. The polarizer on the LCD is easily get scratched. If possible, do not remove the LCD protective film until the last step of installation.
4. Never attempt to disassemble or rework the LCD module.
5. Only Clean the LCD with Isopropyl Alcohol or Ethyl Alcohol. Other solvents (eg. water) may damage the LCD.
6. When mounting the LCD module, make sure that it is free from twisting, warping and distortion.
7. Ensure to provide enough space (with cushion) between case and LCD panel to prevent external force adding on it, or it may cause damage to the LCD or degrade the display result.
8. Only hold the LCD module by its side. Never hold LCD module by add force on the heat seal or TAB.
9. Never add force to component of the LCD module. It may cause invisible damage or degrade of the reliability.
10. LCD module could be easily damaged by static electricity. Be careful to maintain an optimum anti-static work environment to protect the LCD module.
11. When peeling off the protective film from LCD, static charge may cause abnormal display pattern. It is normal and will resume to normal in a short while.
12. Take care and prevent get hurt by the LCD panel sharp edge.
13. Never operate the LCD module exceed the absolute maximum ratings.
14. Keep the signal line as short as possible to prevent noisy signal applying to LCD module.
15. Never apply signal to the LCD module without power supply.
16. IC chip (eg. TAB or COG) is sensitive to the light. Strong lighting environment could possibly cause malfunction. Light sealing structure casing is recommend.
17. LCD module reliability may be reduced by temperature shock.
18. When storing the LCD module, avoid exposure to the direct sunlight, high humidity, high temperature or low temperature. They may damage or degrade the LCD module