

# LM32019TCW

## LCD Module User Manual

Shenzhen TOPWAY Technology Co., Ltd.

Rev.	Descriptions	Release Date
0.1	Preliminary new release	2008-03-11
0.2	Revise VEE supply voltage	2008-06-05

**Table of Content**

<b>1. Basic Specifications</b> .....	<b>3</b>
1.1 Display Specifications .....	3
1.2 Mechanical Specifications .....	3
1.3 Block Diagram.....	3
1.4 Terminal Functions.....	4
<b>2. Absolute Maximum Ratings</b> .....	<b>5</b>
<b>3. Electrical Characteristics</b> .....	<b>5</b>
3.1 DC Characteristics .....	5
3.2 LED Backlight Circuit Characteristics .....	5
3.3 AC Characteristics .....	6
<b>4. Function Specifications</b> .....	<b>7</b>
4.1 Adjusting the Display Contrast .....	7
4.2 Display Pixel Map.....	7
4.3 Signal Sequence .....	8
<b>5. Design and Handling Precaution</b> .....	<b>9</b>

# 1. Basic Specifications

## 1.1 Display Specifications

- 1) LCD Display Mode : FSTN, Positive, Transmissive
- 2) Display Color : Display Data = "1" : Dark Gray (\*1)  
: Display Data = "0" : Light Gray (\*2)
- 3) Driving Method : 1/240 duty, 1/14 bias
- 4) Backlight : White LED backlight

Note: \*1. Color tone may slightly change by Temperature and Driving Condition.  
\*2. The Color is defined as the inactive / background color

## 1.2 Mechanical Specifications

- 1) Outline Dimension : 159.0 x 107.8 x 10.0 MAX.  
see attached Outline Drawing for details

## 1.3 Block Diagram

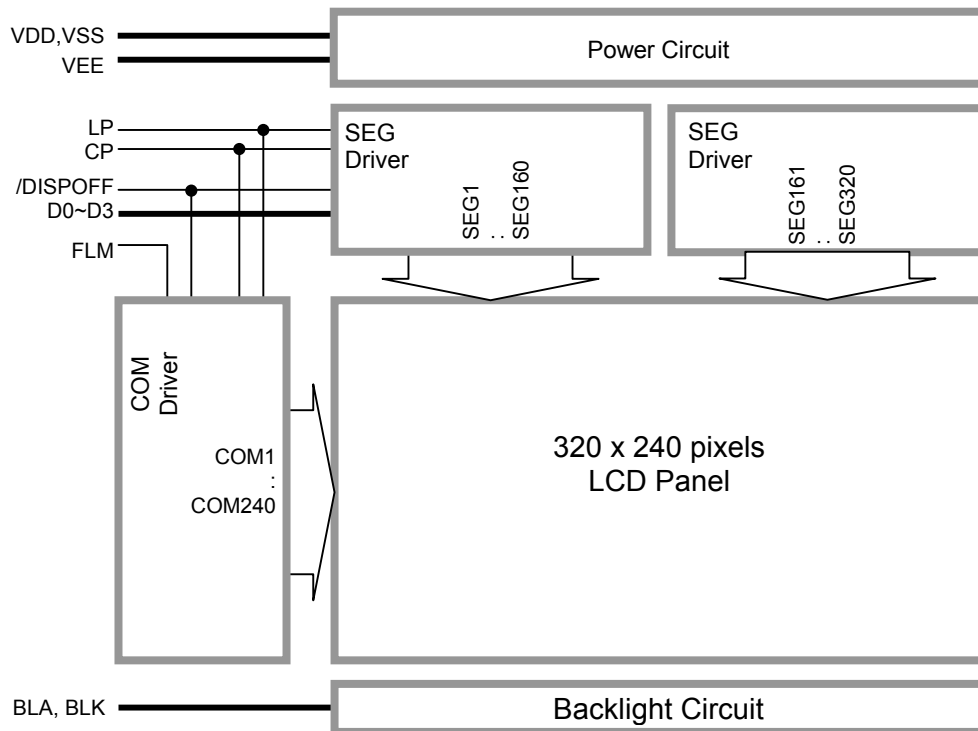

#### 1.4 FFC Terminal Functions

Pin No.	Pin Name	I/O	Descriptions
1	FLM	Input	First Line Marker
2	LP	Input	Line Pulse signal, for latching the segment buffer to the segment driver
3	CP	Input	Clock Pulse signal, for shifting the data (D0~D3) into the segment buffer
4	NC	Input	No connection (leave open)
5	/DISPOFF	Input	Display ON/OFF control signal, /DISPOFF = 0, display off /DISPOFF = 1, display on
6	D0	Input	Display Data
7	D1	Input	Display Data
8	D2	Input	Display Data
9	D3	Input	Display Data
10	VDD	Power	Positive Power Supply
11	VSS	Power	0V Power Supply, GND
12	VEE	Input	LCD Driving Supply

#### 1.5 Backlight Terminal Functions

Pin Color	Pin Name	I/O	Descriptions
Red	BLA	Power	Positive Power Supply for LED backlight
White	BLK	Power	Negative Power Supply for LED backlight

## 2. Absolute Maximum Ratings

Items	Symbol	Min.	Max.	Unit	Condition
Logic Supply	V <sub>DD</sub>	-0.3	+6.0	V	V <sub>SS</sub> = 0V
LCD Driving Supply	V <sub>EE</sub>	-0.3	25	V	V <sub>SS</sub> = 0V
Input Voltage	V <sub>IN</sub>	V <sub>SS</sub> -0.3	V <sub>DD</sub> +0.3	V	V <sub>SS</sub> = 0V
Operating Temperature	T <sub>OP</sub>	-20	70	°C	No Condensation
Storage Temperature	T <sub>ST</sub>	-30	80	°C	No Condensation

Cautions:

Any Stresses exceeding the Absolute Maximum Ratings may cause substantial damage to the device. Functional operation of this device at other conditions beyond those listed in the specification is not implied and prolonged exposure to extreme conditions may affect device reliability.

## 3. Electrical Characteristics

### 3.1 DC Characteristics

V<sub>SS</sub>=0V, V<sub>DD</sub> =5.0V, T<sub>OP</sub> =25°C

Items	Symbol	MIN.	TYP.	MAX.	Unit	Applicable Pin
Logic Supply	V <sub>DD</sub>	3.0	5.0	5.3	V	VDD
LCD Driving Supply	V <sub>EE</sub>	-	22.6	-	V	VEE (*1)
Frame Freq.	f <sub>FRAME</sub>	60	66	80	Hz	
Input High Voltage	V <sub>IN</sub>	0.8xVDD	-	VDD	V	D0~D3, CP, LP, FLM, M, /DISPOFF
Input Low Voltage	V <sub>IN</sub>	0	-	0.2x VDD	V	D0~D3, CP, LP, FLM, M, /DISPOFF
Operating Current	I <sub>DD</sub>	-	0.1	0.5	mA	VDD
LCD Driving current	I <sub>EE</sub>	-	2.0	10.5	mA	VEE

Note:

\*1. Frame freq. at 66Hz

### 3.2 LED Backlight Circuit Characteristics

BLK=0V, I<sub>fBLA</sub>=221mA, T<sub>OP</sub> =25°C

Items	Symbol	MIN.	TYP.	MAX.	Unit	Applicable Pin
Forward Voltage	V <sub>fBLA</sub>	-	5.0	-	V	BLA
Forward Current	I <sub>fBLA</sub>	-	221	290	mA	BLA

Cautions:

Exceeding the recommended driving current could cause substantial damage to the backlight and shorten its lifetime.

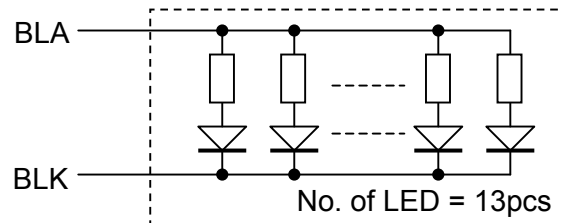

**3.3 AC Characteristics**

$V_{SS}=0V, T_{OP}=25^{\circ}C$

Item	Symbol	$V_{DD}=5.0V$		$V_{DD}=3.3V$		Unit
		MIN.	MAX.	MIN.	MAX.	
Shift clock period (*1)	twck	90	-	160	-	ns
Shift clock "H" pulse width	twckh	30	-	64	-	ns
Shift clock "L" pulse width	twckl	30	-	64	-	ns
SEG Data set-up time	tds	13	-	38	-	ns
SEG Data hold time	tdh	13	-	50	-	ns
Latch pulse "H" pulse width	twlph	30	-	64	-	ns
Shift clock rise to latch pulse rise time	tld	9	-	9	-	ns
Shift clock fall to latch pulse fall time	tsl	32	-	64	-	ns
Latch pulse rise to shift clock rise time	tls	32	-	64	-	ns
Latch pulse fall to shift clock fall time	tlh	32	-	64	-	ns
Rise time	tr	-	40	-	40	ns
Fall time	tf	-	40	-	40	ns
/DISPOFF removal time	tsd	125	-	125	-	ns
/DISPOFF "L" pulse width	twdl	1500	-	1500	-	ns
COM Data setup time	tsu	38	-	38	-	ns
COM Data hold time	th	63	-	63	-	ns

Note: \*1.  $t_r, t_f < 9ns$

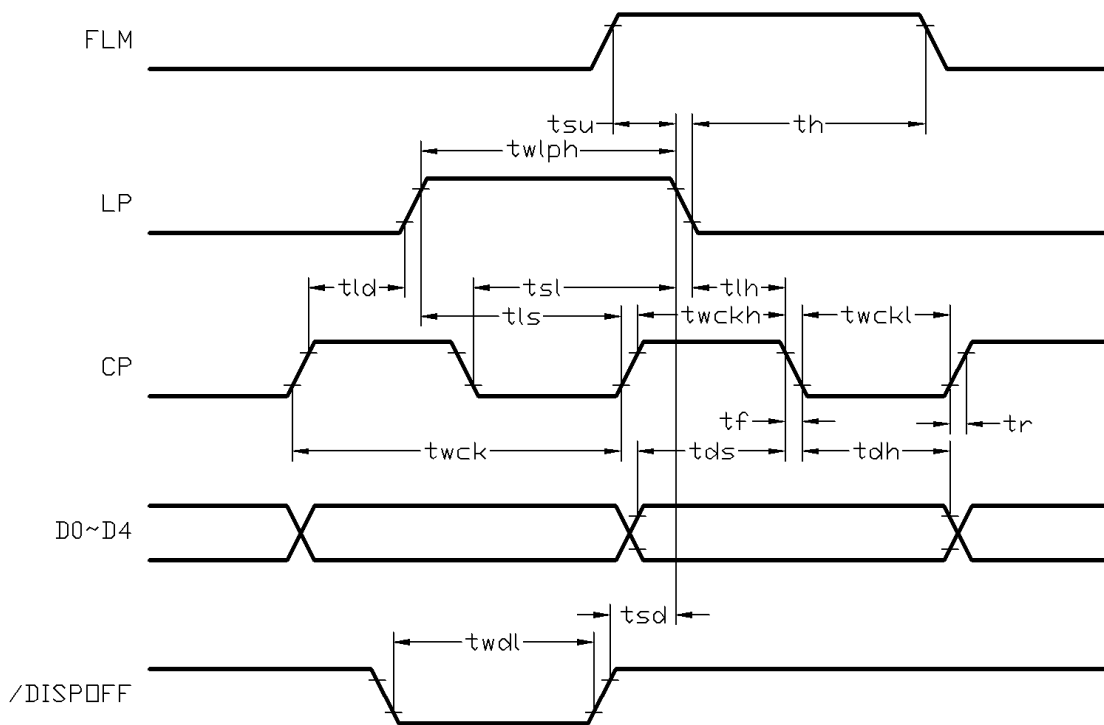

**Interface Timing Diagram**

## 4. Function Specifications

### 4.1 Adjusting the Display Contrast

Adjusting the LCD Driving Supply on the VEE will result the change of LCD display contrast. The following is a simplest circuit to provide a variable voltage on VEE.

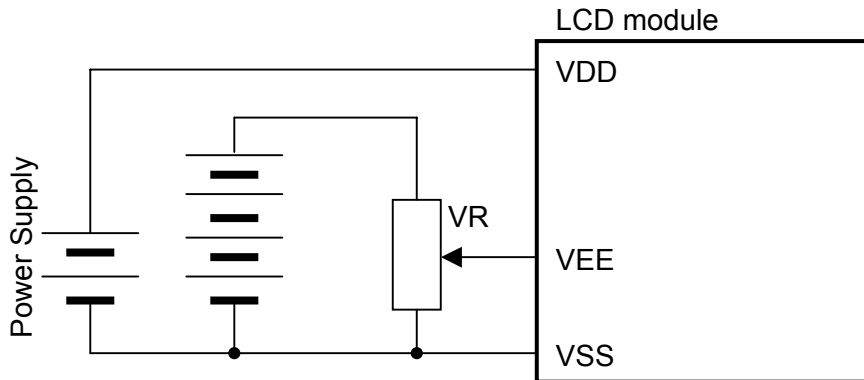

### 4.2 Display Pixel Map

1,1 (D3)	2,1 (D2)	3,1 (D1)	4,1 (D0)	5,1 (D3)	---	---	316,1 (D0)	317,1 (D3)	318,1 (D2)	319,1 (D1)	320,1 (D0)
1,2 (D3)	2,2 (D2)	3,2 (D1)	4,2 (D0)	5,2 (D3)	---	---	316,2 (D0)	317,2 (D3)	318,2 (D2)	319,2 (D1)	320,2 (D0)
1,3 (D3)	2,3 (D2)	3,3 (D1)	4,3 (D0)	5,3 (D3)	---	---	316,3 (D0)	317,3 (D3)	318,3 (D2)	319,3 (D1)	320,3 (D0)
:	:	:	:	:	:	:	:	:	:	:	:
:	:	:	:	:	:	:	:	:	:	:	:
:	:	:	:	:	:	:	:	:	:	:	:
1,238 (D3)	2,238 (D2)	3,238 (D1)	4,238 (D0)	5,238 (D3)	---	---	316,238 (D0)	317,238 (D3)	318,238 (D2)	319,238 (D1)	320,238 (D0)
1,239 (D3)	2,239 (D2)	3,239 (D1)	4,239 (D0)	5,239 (D3)	---	---	316,239 (D0)	317,239 (D3)	318,239 (D2)	319,239 (D1)	320,239 (D0)
1,240 (D3)	2,240 (D2)	3,240 (D1)	4,240 (D0)	5,240 (D3)	---	---	316,240 (D0)	317,240 (D3)	318,240 (D2)	319,240 (D1)	320,240 (D0)

Pixel mapping (Top View)

Based on the top view of the LCD module, the 1, 1 (x, y) pixel is the upper-left pixel; the 320, 240 (x, y) pixel is the lower-right pixel.

4.3 Signal Sequence

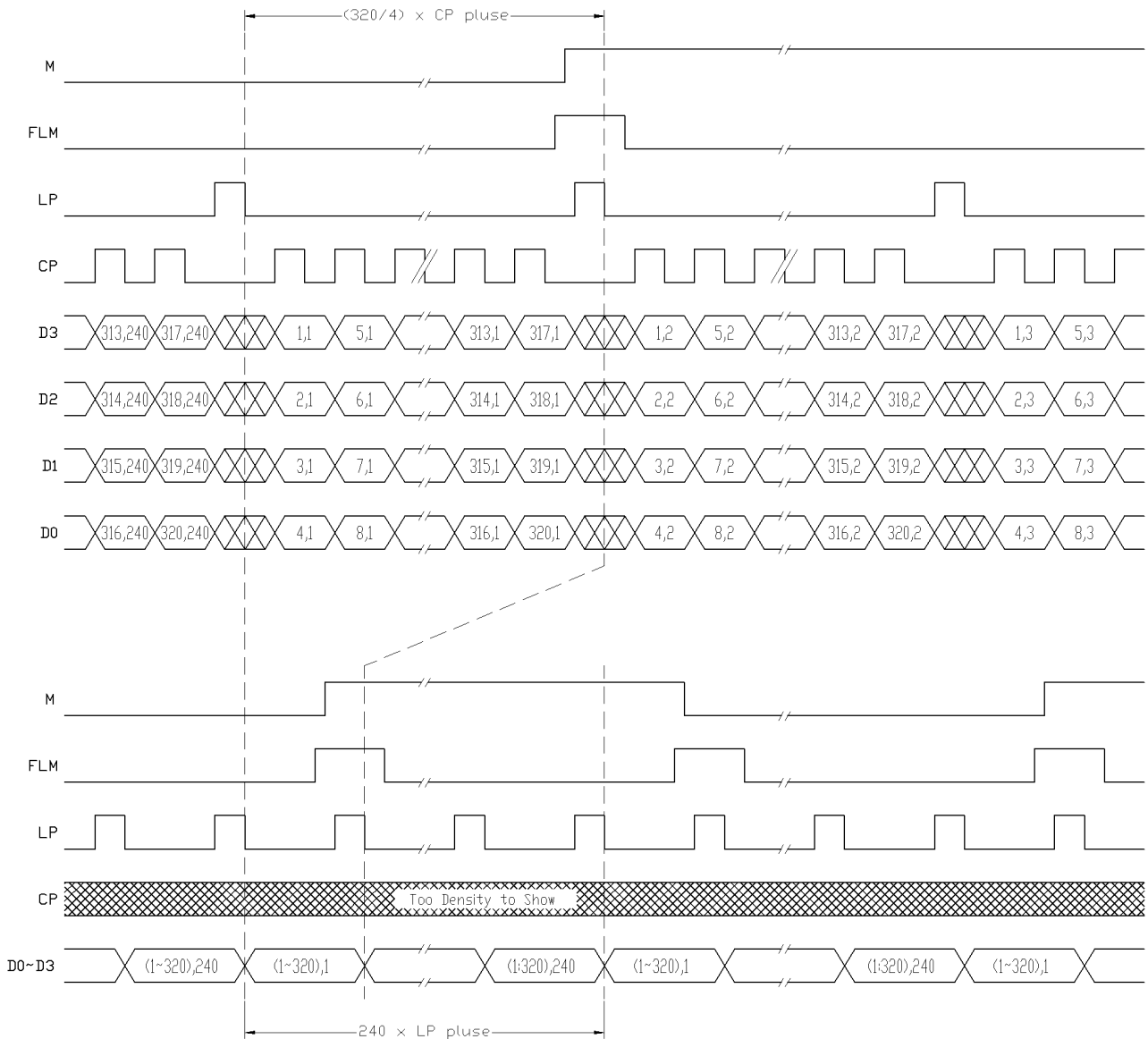

In the upper section (expanded view), shows the data sequence of lines.

In the lower section (compressed view), shows the signal sequence of FLM, LP and M in frames.

## 5. Design and Handling Precaution

1. The LCD panel is made by glass. Any mechanical shock (eg. dropping from high place) will damage the LCD module.
2. Do not add excessive force on the surface of the display, which may cause the Display color change abnormally.
3. The polarizer on the LCD is easily get scratched. If possible, do not remove the LCD protective film until the last step of installation.
4. Never attempt to disassemble or rework the LCD module.
5. Only Clean the LCD with Isopropyl Alcohol or Ethyl Alcohol. Other solvents (eg. water) may damage the LCD.
6. When mounting the LCD module, make sure that it is free from twisting, warping and distortion.
7. Ensure to provide enough space (with cushion) between case and LCD panel to prevent external force adding on it, or it may cause damage to the LCD or degrade the display result.
8. Only hold the LCD module by its side. Never hold LCD module by add force on the heat seal or TAB.
9. Never add force to component of the LCD module. It may cause invisible damage or degrade of the reliability.
10. LCD module could be easily damaged by static electricity. Be careful to maintain an optimum anti-static work environment to protect the LCD module.
11. When peeling off the protective film from LCD, static charge may cause abnormal display pattern. It is normal and will resume to normal in a short while.
12. Take care and prevent get hurt by the LCD panel sharp edge.
13. Never operate the LCD module exceed the absolute maximum ratings.
14. Keep the signal line as short as possible to prevent noisy signal applying to LCD module.
15. Never apply signal to the LCD module without power supply.
16. IC chip (eg. TAB or COG) is sensitive to the light. Strong lighting environment could possibly cause malfunction. Light sealing structure casing is recommend.
17. LCD module reliability may be reduced by temperature shock.
18. When storing the LCD module, avoid exposure to the direct sunlight, high humidity, high temperature or low temperature. They may damage or degrade the LCD module