



深圳市拓普微科技开发有限公司

SHENZHEN TOPWAY TECHNOLOGY CO., LTD.

# LM192160ACW

## LCD Module User Manual

Prepared by:  <b>Luolailiang</b>  Date: 2012-04-11	Checked by:    Date:	Approved by:    Date:
--	----------------------------------	-----------------------------------

Rev.	Descriptions	Release Date
0.1	Preliminary release	2012-04-11

**Table of Content**

<b>1. Basic Specifications .....</b>	<b>3</b>
1.1 Display Specifications .....	3
1.2 Mechanical Specifications .....	3
1.3 Block Diagram.....	3
1.4 Terminal Functions.....	4
<b>2. Absolute Maximum Ratings .....</b>	<b>5</b>
<b>3. Electrical Characteristics .....</b>	<b>5</b>
3.1 DC Characteristics .....	5
3.2 LED Backlight Circuit Characteristics .....	5
3.3 AC Characteristics .....	6
3.4 Reset Timing.....	8
<b>4. Function Specifications .....</b>	<b>9</b>
4.1 Adjusting the Display Contrast .....	9
4.2 Application circuit (Example).....	9
4.3 Resetting the LCD module .....	9
4.4 Display Memory Map .....	10
4.5 Commands.....	11
4.6 Command Table.....	14
<b>5. Design and Handling Precaution.....</b>	<b>15</b>

# 1. Basic Specifications

## 1.1 Display Specifications

- 1) LCD Display Mode : FSTN, Positive, Transflective
- 2) Display Color : Display Data = "1" : Light Gray (\*1)  
: Display Data = "0" : Dark Blue (\*2)
- 3) Viewing Angle : 6H
- 4) Driving Method : 1/160 duty, 1/10 bias
- 5) Back Light : White LED backlight

Note:

\*1. Color tone may slightly change by Temperature and Driving Condition.

\*2. The Color is defined as the inactive / background color

\*3. Fine Contrast adjustment function is necessary in the application design for optimal display result

## 1.2 Mechanical Specifications

- 1) Outline Dimension : 76.7 x 71.6 x 7.6 (Exclude FPC)  
(See attached Outline Drawing for details)

## 1.3 Block Diagram

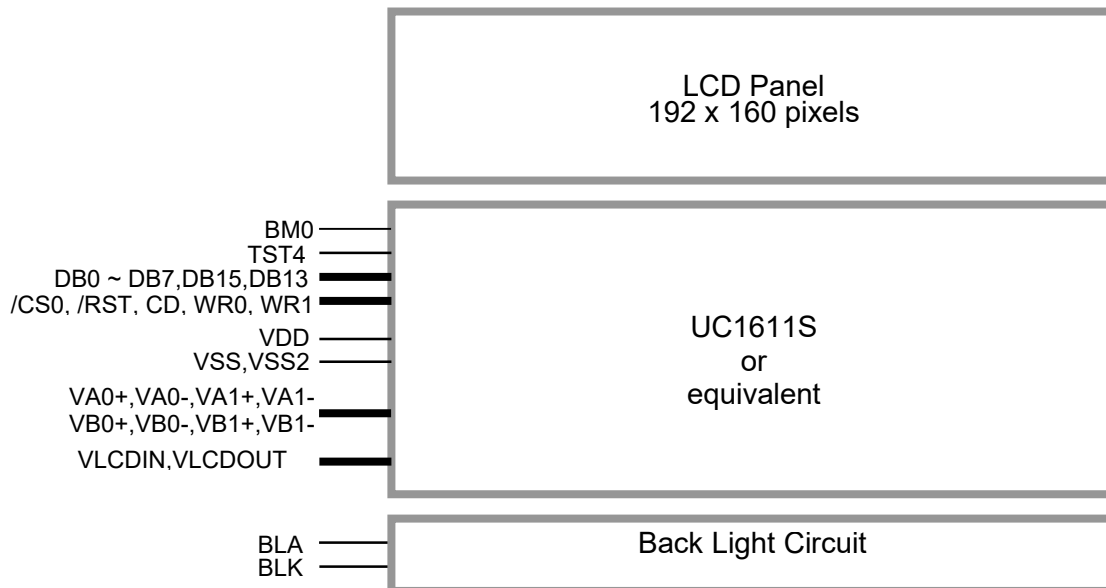

**1.4 Terminal Functions**

Pin No.	Pin Name	I/O	Descriptions			
			8-bit parallel 8080 mode	8-bit parallel 6800 mode	Serial mode 4Line	
1	VSS2	Power	Connect to VSS			
2	DB15	I/O	L	L	H	
3	DB13	I/O	L	L	L	
4	DB7	I/O	8-bit Data bus; Three state I/O terminal for display data or instruction data when /CS =H, DB0~DB7=High Impedance			Not use, Connect to VSS
:	:					Serial data input(DB3)
7	DB3(SDA)					Not use, Connect to VSS
:	:					Serial clock input(DB0)
11	DB0(SCL)					
12	/RST	Input	Reset: /RST=LOW: Initialization is executed /RST=HIGH: Normal			
13	/CS0	Input	Chip Select /CS0=LOW : Data IO is enabled			
14	CD	Input	Register Select CD=HIGH: data on DB0 to DB7 is display data CD=LOW: data on DB0 to DB7 is control data			
15	WR0	Input	WR0=L→H, WR1=H; Data or Instruction latch into the LCD module	WR0=H,WR1=H; Data or Status read from the LCD module WR0=L,WR1=H→L; Data or Status latch into the LCD module	Not used, Connect to VSS	
16	WR1	Input	WR0=H, WR1=L; Data or Status read form the LCD module			
17	NC	-	Not connection(Leave open)			
18	BM0	Input	L	H	L	
19	TST4	-	Not use(Leave open)			
20	VSS	Power	0V Supply, Ground (0V)			
21	VDD	Power	Positive Power Supply			
22	VLCDIN	Power	High voltage LCD Power Supply			
23	VLCDOUT	Power	High voltage LCD Power Supply			
24	VA0-	Power	LCD driving voltage supply terminals			
25	VA1-					
26	VA1+					
27	VA0+					
28	VB0-					
29	VB1-					
30	VB1+					
31	VB0+					
32	VSS2	Power	Connect to VSS			
/	BLA	Power	Backlight Positive Power Supply			
/	BLK	Power	Backlight Negative Power Supply			

Note: About Interface setting, please refer to UC1611 datasheet for more detail.

## 2. Absolute Maximum Ratings

Items	Symbol	Min.	Max.	Unit	Condition
Supply Voltage	$V_{DD}$	-0.3	+4.0	V	$V_{SS} = 0V$
Input Voltage	$V_{IN}$	-0.3	$V_{DD}+0.3$	V	$V_{SS} = 0V$
Operating Temperature	$T_{OP}$	-20	+70	°C	No Condensation
Storage Temperature	$T_{ST}$	-30	+80	°C	No Condensation

Cautions:

Any Stresses exceeding the Absolute Maximum Ratings may cause substantial damage to the device. Functional operation of this device at other conditions beyond those listed in the specification is not implied and prolonged exposure to extreme conditions may affect device reliability.

## 3. Electrical Characteristics

### 3.1 DC Characteristics

$V_{SS}=0V, V_{DD}=3.3V, T_{OP}=25^{\circ}C$

Items	Symbol	MIN.	TYP.	MAX.	Unit	Condition / Application Pin
Operating Voltage	$V_{DD}$	3.0	3.3	3.6	V	VDD
Input High Voltage	$V_{IH}$	$0.8 \times V_{DD}$	-	$V_{DD}$	V	/RST, /CS0, CD, WR0,
Input Low Voltage	$V_{IL}$	0	-	$0.2 \times V_{DD}$	V	WR1, DB0~DB7
Operating Current	$I_{DD}$	-	1.4	3.5	mA	VDD

### 3.2 LED Backlight Circuit Characteristics

$V_{SS}=0V, I_{f_{BLA}}=102mA, T_{OP}=25^{\circ}C$

Items	Symbol	MIN.	TYP.	MAX.	Unit	Applicable Pin
Forward Voltage	$V_{f_{BLA}}$	-	3.3	-	V	BLA
Forward Current	$I_{f_{BLA}}$	-	102	120	mA	BLA

Cautions:

Exceeding the recommended driving current could cause substantial damage to the backlight and shorten its lifetime.

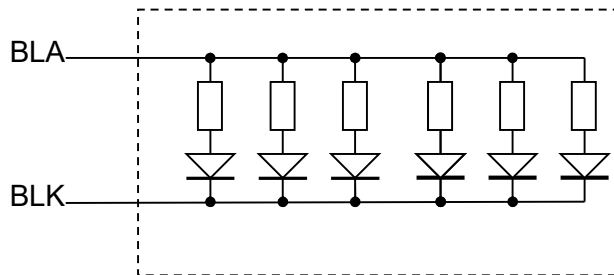

**3.3 AC Characteristics**

**3.3.1 8080 Mode System Bus Timing**

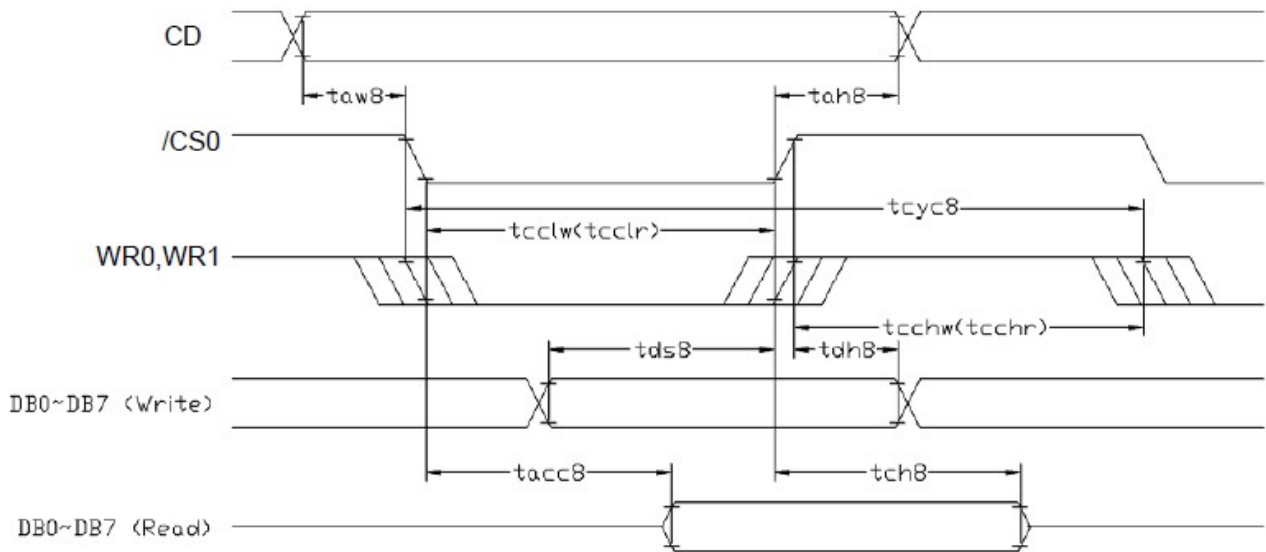

$V_{SS}=0V, V_{DD}=3.3V, T_{OP}=25^{\circ}C$

Item	Symbol	MIN.	TYP.	MAX.	Unit
System cycle time	tcyc8	185	-	-	ns
Address setup time (CD)	taw8	10	-	-	ns
Address hold time (CD)	tah8	10	-	-	ns
Control LOW pulse width (WR0)	tcclw	93	-	-	ns
Control LOW pulse width (WR1)	tcclr	93	-	-	ns
Control HIGH pulse width (WR0)	tcchw	93	-	-	ns
Control HIGH pulse width (WR1)	tcchr	93	-	-	ns
Data setup time	tds8	43	-	-	ns
Data hold time	tdh8	10	-	-	ns
WR1 access time (*2)	tacc8	-	-	85	ns
Output disable time (*2)	tch8	21	-	-	ns

Note:

\*1. Input signal rise/fall time should be less than 12ns

\*2. CL=100pF

**3.3.2 6800 Mode System Bus Timing**

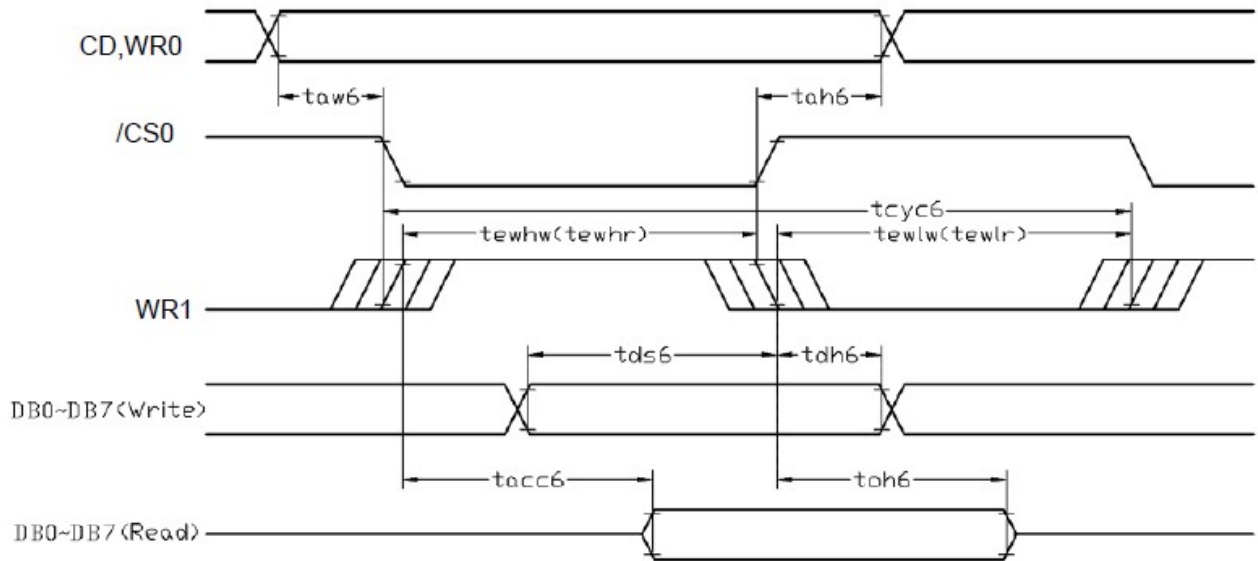

$V_{SS}=0V, V_{DD}=3.3V, T_{OP}=25^{\circ}C$

Item	Symbol	MIN.	TYP.	MAX.	Unit
System cycle time	$t_{cyc6}$	185	-	-	ns
Address setup time (CD)	$t_{aw6}$	10	-	-	ns
Address hold time (CD)	$t_{ah6}$	10	-	-	ns
Control LOW pulse width (WR0)	$t_{ewlr}$	93	-	-	ns
Control LOW pulse width (WR0)	$t_{ewlw}$	93	-	-	ns
Control HIGH pulse width (WR1)	$t_{ewhr}$	93	-	-	ns
Control HIGH pulse width (WR0)	$t_{ewhw}$	93	-	-	ns
Data setup time	$t_{ds6}$	43	-	-	ns
Data hold time	$t_{dh6}$	10	-	-	ns
WR1 access time (*2)	$t_{acc6}$	-	-	85	ns
Output disable time (*2)	$t_{oh6}$	21	-	-	ns

Note:

\*1. Input signal rise/fall time should be less than 12ns

\*2.  $C_L=100pF$

3.3.3 Serial Mode Interface

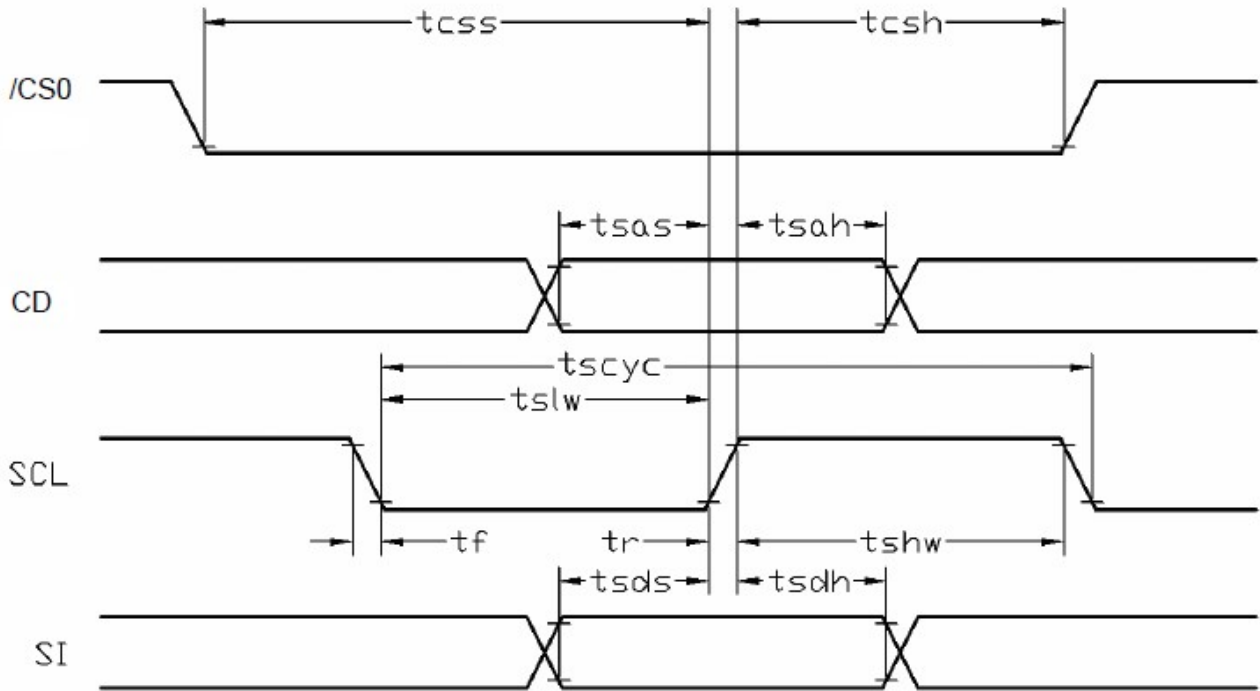

V<sub>SS</sub>=0V, V<sub>DD</sub>=3.3V, T<sub>OP</sub>=25°C

Item	Symbol	MIN.	TYP.	MAX.	Unit
Serial Clock Period	tscyc	51	-	-	ns
Address setup time (CD)	tsas	10	-	-	ns
Address hold time (CD)	tsah	10	-	-	ns
SCL "H" pulse width	tshw	26	-	-	ns
SCL "L" pulse width	tslw	26	-	-	ns
Data setup time	tsds	21	-	-	ns
Data hold time	tsdh	10	-	-	ns
CS-SCL time	tcss	10	-	-	ns
CS-SCL time	tcsh	10	-	-	ns

Note:

\*1. Input signal rise/fall time should be less than 12ns

3.4 Reset Timing

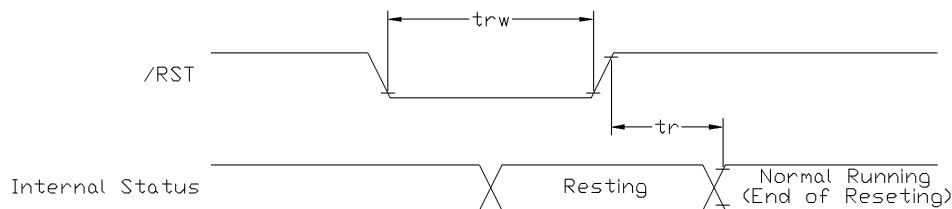

V<sub>SS</sub>=0V, V<sub>DD</sub>=3.3V, T<sub>OP</sub>=25°C

Item	Symbol	MIN.	TYP.	MAX.	Unit
Reset time	tr	-	-	15	ms
Reset LOW pulse width	trw	4	-	-	μs

Note:

\*1. Input signal rise/fall time should be less than 12ns



## 4. Function Specifications

### 4.1 Adjusting the Display Contrast

- This LCD module equipped with latest digital contrast adjustment function.
- Its display contrast could be adjusted by MCU command. (please see the command tables for details)
- It is recommended to provide a contrast adjustment interface for end-user, where the best display result could meet the individual preference in mass production.

### 4.2 Application circuit (Example)

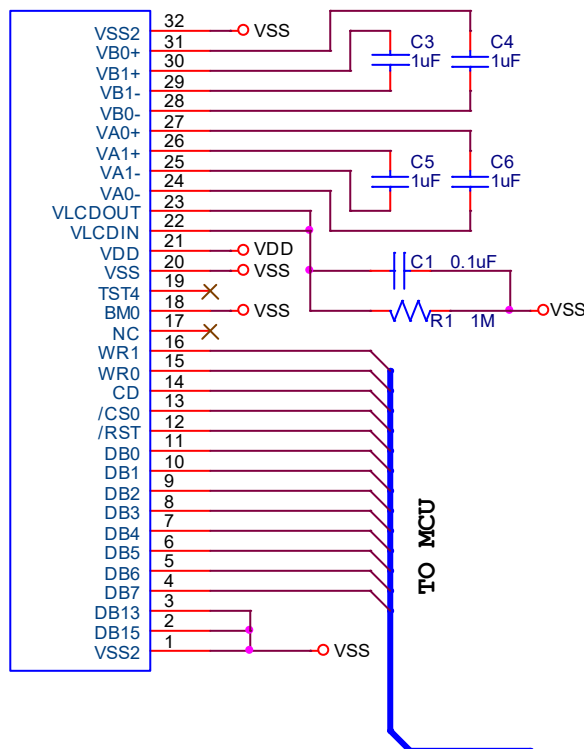

NOTE: 8080 mode (Default setting), please refer to UC1611 datasheet for details.

### 4.3 Resetting the LCD module

The LCD module should be initialized by using /RST terminal. While turning on the VDD and VSS power supply, maintain /RST terminal at LOW level. After the power supply stabilized, release the reset terminal (/RST=HIGH)

**4.4 Display Memory Map**

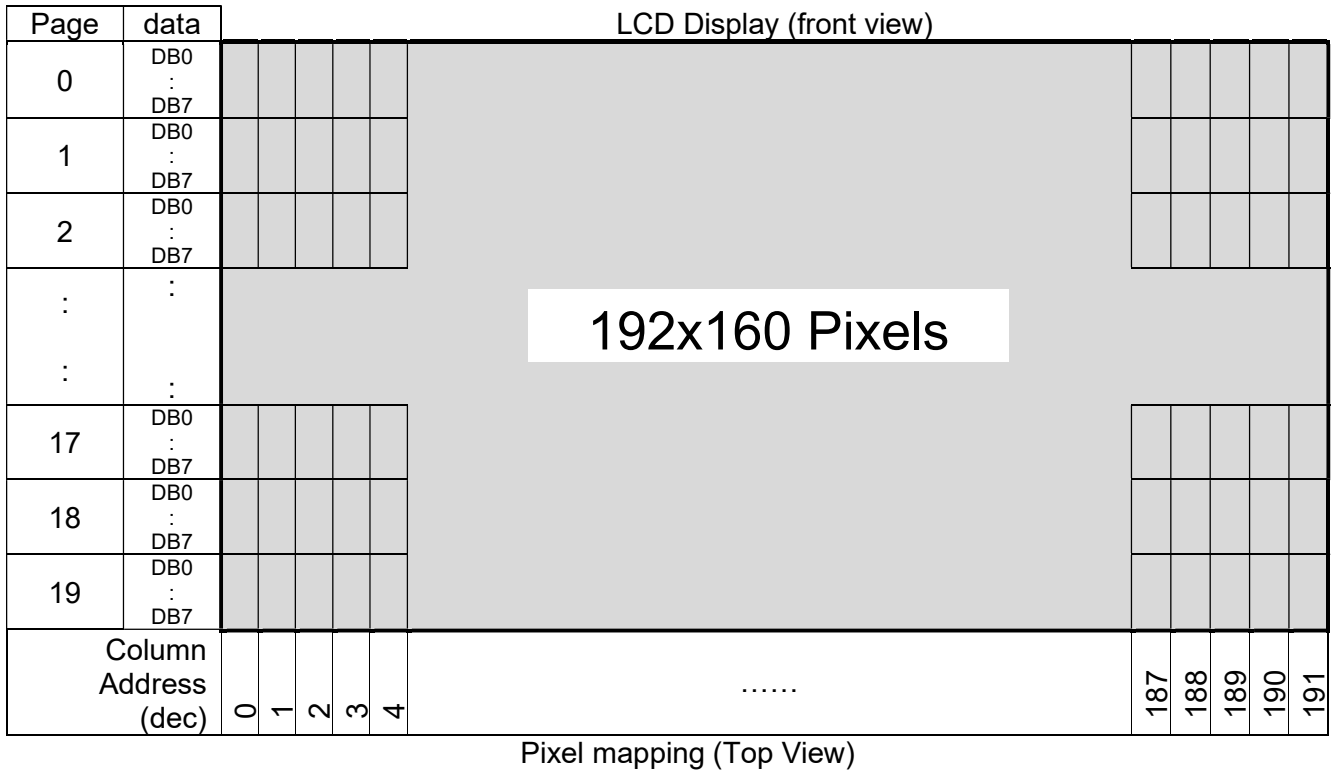

Note:

- \*1. Based on the top view of the LCD module,
- \*2. The above is memory map based on:  
 On/Off mode setting, DC[5:3]=100 (1bpp), the Page value range:0~19  
 LC[0]=MSF=0  
 LC[1]=MX=1  
 LC[2]=MY=0  
 SL=0
- \*3. For 4,8 and 16 Gray-shade operation please refer to UC1611 datasheet.

## 4.5 Commands

### 4.5.1 Register Table

Name	Bits	Default	Description
SL	8	00H	Scroll Line. Scroll the displayed image up by SL rows. The valid SL value are between 0 (for no scrolling) and (159 – FL). Setting SL outside of this range causes undefined effect on the displayed image.
FL	4	0H	Fixed lines. The first (FLx2) lines of each frame are fixed and are not affected by scrolling (SL). When FL is non-zero, the screen is effectively separated into two regions: one scrollable, one non-scrollable.
CA	8	00H	Display Data RAM Column Address (Used in Host to Display Data RAM access)
PA	7	00H	Display Data RAM Page Address (Used in Host for Display Data RAM access) When DC[5:3] = 100b, PA[6:5] : used to select Write Pattern 0~3. PA[4:0] : set SRAM page address
BR	2	2H	Bias Ratio. The ratio between $V_{LCD}$ and $V_{BIAS}$ . 00b: 5                      01b: 10 <b>10b: 11                    11b: 12</b>
TC	2	0H	Temperature Compensation (per °C). <b>00b: -0.05%</b> 01b: -0.10% 10b: -0.15%            11b: 0.00%
PM	8	EAH	Electronic Potentiometer to fine tune $V_{BIAS}$ and $V_{LCD}$
PMO	6	00H	PM offset. the effective PM value, $PMV = PM - PMO[4:0]$ when $PMO[5]=1$ the effective PM value, $PMV = PM + PMO[4:0]$ when $PMO[5]=0$
PC	4	FH	Pump Control. PC[1:0]: Panel Loading 00b: LCD: $\leq 33nF$ <b>11b: <math>33nF \leq LCD \leq 55nF</math></b> PC[3:2]: Pump Control 00b: External $V_{LCD}$ <b>11b: Internal <math>V_{LCD}</math> (11x charge pump)</b> (Setting to 01 or 10 will be invalid and default value will be used instead.)
AC	4	1H	Address Control: AC[0]: WA: Automatic column/page Wrap Around (Default <b>1:ON</b> ) AC[1]: Auto-Increment order <b>0: Column (CA) first</b> 1: Page (PA) first AC[2]: PID: PA (page address) auto increment direction ( <b>0:+1</b> , 1:-1) AC[3]: Window Program Mode <b>0 : Inside Mode:</b> Write to SRAM within the window defined by (WPC0,WPP0), (WPC1,WPP1) 1 : Outside Mode: Write to SRAM but skip the window defined by (WPC0,WPP0), (WPC1,WPP1)

**Register Table (continue)**

Name	Bits	Default	Description																									
DC	8	18H	Display Control: DC[0]: PXV: Pixels Inverse. Bit-wise data inversion. (Default <b>0:OFF</b> ) DC[1]: APO: All Pixels ON (Default <b>0:OFF</b> ) DC[2]: Display ON/OFF (Default <b>0:OFF</b> ) DC[4:3]: Gray-shade Modulation mode. 00 : On/Off mode                      01: 8-shade Mode 10 : 4-shade Mode <b>11: 16-shade mode</b> DC[5]: Input Type of On/Off Mode (enable only when DC[4:3]=00b) <b>0: 4-bit per 1-pixel</b> 1: 1-bit per 1-pixel DC[7:6]: Display Pattern Selection (enable only when DC[5:3]=100b) <b>00: Pattern0</b> 01: Pattern1 10: Pattern2                          11: Pattern3																									
LC	10	020H	LCD Control: LC[0]: MSF: MSB First mapping Option (Default: <b>0:OFF</b> ) LC[1]: MX, Mirror X. SEG/Column sequence inversion (Default: <b>0:OFF</b> ) LC[2]: MY, Mirror Y. COM/Row sequence inversion (Default: <b>0:OFF</b> ) LC[3]: Enable FL lines in partial display mode.(Default: <b>0:OFF</b> ) LC[5:4]: Line Rate (= Frame-Rate x Mux-Rate) <table border="1" style="margin-left: 40px; margin-top: 10px;"> <thead> <tr> <th></th> <th>LC[5:4]=00b</th> <th>01b</th> <th><b>10b</b></th> <th>11b</th> </tr> </thead> <tbody> <tr> <td><b>16-shade</b></td> <td>20.0 Klps</td> <td>24.0</td> <td><b>28.0</b></td> <td>32.0</td> </tr> <tr> <td>8-shade</td> <td>14.1</td> <td>16.9</td> <td><b>19.7</b></td> <td>22.5</td> </tr> <tr> <td>4-shade</td> <td>13.3</td> <td>16.0</td> <td><b>18.7</b></td> <td>21.4</td> </tr> <tr> <td>On/Off mode</td> <td>5.9</td> <td>7.1</td> <td><b>8.2</b></td> <td>9.4</td> </tr> </tbody> </table> <p style="text-align: right;">( Klps: Kilo-Line-per-second )</p> LC[7:6] : Reserved (Default : <b>00b</b> ) LC[9:8] : Partial Display Control <b>0xb: Disable</b> Mux-rate = CEN+1    (DST and DEN are not used.) 11b: Enabled        Mux-rate = DEN-DST+1+LC[3]xFLx2		LC[5:4]=00b	01b	<b>10b</b>	11b	<b>16-shade</b>	20.0 Klps	24.0	<b>28.0</b>	32.0	8-shade	14.1	16.9	<b>19.7</b>	22.5	4-shade	13.3	16.0	<b>18.7</b>	21.4	On/Off mode	5.9	7.1	<b>8.2</b>	9.4
	LC[5:4]=00b	01b	<b>10b</b>	11b																								
<b>16-shade</b>	20.0 Klps	24.0	<b>28.0</b>	32.0																								
8-shade	14.1	16.9	<b>19.7</b>	22.5																								
4-shade	13.3	16.0	<b>18.7</b>	21.4																								
On/Off mode	5.9	7.1	<b>8.2</b>	9.4																								
NIV	7	00H	N-Line Inversion NIV[5:0] : <b>000000b : Disable N-line Inversion</b> NIV[6] : <b>0b: no-XOR</b> 1b: XOR																									
CEN DST DEN	8 8 8	9FH 00H 9FH	COM scanning ENd (the last COM with full line cycle, 0-based index) Display STart (the first COM with active scan pulse, 0-based index) Display EDd (the last COM with active scan pulse, 0-based index) Please maintain the following relationship: CEN = (the actual number of pixel rows on the LCD) – 1 CEN ≥ DEN ≥ DST+ 9																									
ISOF	4	1H	Set the ISOLation clock in Front of COM pulse.																									
ISOB	4	0H	Set the ISOLation clock in Back of COM pulse.																									
WPC0	8	00H	Window program starting column address. Value range: 0 ~255.																									
WPP0	6	00H	Window program starting row address. Value range: 0~79. When DC[5:3]=100b, value range: 0~19																									
WPC1	8	FFH	Window program ending column address. Value range: 0~255.																									
WPP1	6	4FH	Window program ending row address. Value range: 0~79. When DC[5:3]=100b, value range: 0~19																									

**Register Table (continue)**

Name	Bits	Default	Description
MTPC	5	10H	MTP Programming Control: MTPC[2:0] : MTP command <b>000 : Idle</b> 001 : Read 010 : Erase           011 : Program 1xx : For UltraChip debug use only MTPC[3] : MTP Enable (automatically cleared after each MTP command) MTPC[4] : Ignore/Use MTP. 0: Ignore <b>1: Use</b>
MTPM	6	00H	MTP Write Mask.. 0: no action 1: program
APC	1	N/A	Advanced Product Configuration. For UltraChip only. Please do not use.
<b>Status Registers</b>			
OM	2	–	Operating Modes (Read Only) 00b: Reset   01b: (Not used) 10b: Sleep   11b: Normal
MD	1	–	MTP option flag. 0 : for non-MTP version.   1 : for MTP version
MS	1	–	MTP programming in-progress
WS	1	–	MTP Operation Succeeded

**4.6 Command Table**

The following setting should be issue to LCD module after hardware reset.  
(It is an example only; it could be adjusted if necessary.)

	Command	D/C	W/R	D7	D6	D5	D4	D3	D2	D1	D0	Action	Default
1.	Write Data Byte	1	0	#	#	#	#	#	#	#	#	Write 1 byte	N/A
2.	Read Data Byte	1	1	#	#	#	#	#	#	#	#	Read 1 byte	N/A
3.	Get Status	0	1	Ver	MX	MY	WA	DE	WS	MD	MS	Get Status	N/A
				ID[1:0]				PMO[5:0]					
				Product Code				0	0	0	EF		
4.	Set Column Addr. LSB	0	0	0	0	0	0	#	#	#	#	Set CA[3:0]	0
	Set Column Addr. MSB	0	0	0	0	0	1	#	#	#	#	Set CA[7:4]	0
5.	Temp. Compensation.	0	0	0	0	1	0	0	1	#	#	Set TC[1:0]	00b: -0.05%/°C
6.	Set Panel Loading	0	0	0	0	1	0	1	0	#	#	Set PC [1:0]	11b: 33~55 nF
7.	Set Pump Control	0	0	0	0	1	0	1	1	#	#	Set PC [3:2]	11b
8.	Set Adv. Program Control (double-byte command)	0	0	0	0	1	1	0	0	R	R	Set APC[R][7:0] R = 0~3	N/A
				#	#	#	#	#	#	#	#		
9.	Set Scroll Line LSB	0	0	0	1	0	0	#	#	#	#	Set SL[3:0]	0
	Set Scroll Line MSB			0	1	0	1	#	#	#	#	Set SL[7:4]	0
10.	Set Page Address LSB	0	0	0	1	1	0	#	#	#	#	Set PA[3:0]	0
	Set Page Address MSB			0	1	1	1	0	#	#	#	Set PA[6:4]	0
11.	Set Potentiometer (double-byte command)	0	0	1	0	0	0	0	0	0	1	Set PM[7:0]	PM=EAH
				#	#	#	#	#	#	#	#		
12.	Set Isolation Clock Front	0	0	1	0	0	0	0	0	1	0	Set ISOF[3:0]	1H
				0	0	0	1	0	0	1	1		
				-	-	-	-	#	#	#	#		
13.	Set Isolation Clock Back	0	0	1	0	0	0	0	0	1	0	Set ISOB[3:0]	0H
				0	0	0	1	0	1	0	0		
				-	-	-	-	#	#	#	#		
14.	Set Partial Display Control	0	0	1	0	0	0	0	1	#	#	Set LC[9:8]	00b: Disable
15.	Set RAM Address Control	0	0	1	0	0	0	1	#	#	#	Set AC[2:0]	001b
16.	Set Fixed Lines	0	0	1	0	0	1	#	#	#	#	Set FL[3:0]	0
17.	Set Line Rate	0	0	1	0	1	0	0	0	#	#	Set LC[5:4]	10b:28klps
18.	Set All-Pixel-ON	0	0	1	0	1	0	0	1	0	#	Set DC[1]	0
19.	Set Inverse Display	0	0	1	0	1	0	0	1	1	#	Set DC[0]	0
20.	Set Display Enable	0	0	1	0	1	0	1	#	#	#	Set DC[4:2]	110b
21.	Set LCD Mapping Control (double-byte command)	0	0	1	1	0	0	0	0	0	0	Set LC[3:0]	0
				0	0	0	0	#	#	#	#		
22.	Set N-line Inversion (double-byte command)	0	0	1	1	0	0	1	0	0	0	Set NIV[6:0]	00H
				-	#	#	#	#	#	#	#		
23.	Set Display Pattern	0	0	1	1	0	1	0	#	#	#	Set DC[7:5]	000b
24.	System Reset	0	0	1	1	1	0	0	0	1	0	System Reset	N/A
25.	NOP	0	0	1	1	1	0	0	0	1	1	No operation	N/A
26.	Set test control (double-byte command)	0	0	1	1	1	0	0	1	TT		For testing only. Do not use.	N/A
				#	#	#	#	#	#	#	#		
27.	Set LCD Bias Ratio	0	0	1	1	1	0	1	0	#	#	Set BR[1:0]	10b: 11
28.	Set COM End	0	0	1	1	1	1	0	0	0	1	Set CEN[7:0]	159
				#	#	#	#	#	#	#	#		
29.	Set Partial Display Start	0	0	1	1	1	1	0	0	1	0	Set DST[7:0]	0
				#	#	#	#	#	#	#	#		
30.	Set Partial Display End	0	0	1	1	1	1	0	0	1	1	Set DEN[7:0]	159
				#	#	#	#	#	#	#	#		

Note:  
Please refer to UC1611 data sheet for details  
R/W=0 means it is a write function, R/W=1 means it is a read function  
D/C=0 means it is a control data, D/C=1 means it is a display data

## 5. Design and Handling Precaution

Please refer to "LCD-Module-Design-Handling-Precaution.pdf".

