



深圳市拓普微科技开发有限公司

SHENZHEN TOPWAY TECHNOLOGY CO., LTD.

LM6029ACW

LCD Module User Manual

Prepared by: Yang Lin Date: 2010-06-10	Checked by: Date:	Approved by: Date:
---	----------------------------------	-----------------------------------

Rev.	Descriptions	Release Date
0.1	Preliminary release	2008-07-23
0.2	Typing correction on Display Command Table Heading	2009-05-15
0.3	Typing correction on Terminal Functions	2009-05-19
0.4	Refine Terminal Functions Discription	2010-06-10

Table of Content

1. Basic Specifications	3
1.1 Display Specifications	3
1.2 Mechanical Specifications	3
1.3 Block Diagram	3
1.4 Terminal Functions	4
2. Absolute Maximum Ratings	5
3. Electrical Characteristics	5
3.1 DC Characteristics	5
3.2 LED Backlight Circuit Characteristics	5
3.3 AC Characteristics	6
4. Function specifications	7
4.1 Basic Setting	7
4.2 Resetting the LCD module	7
4.3 Display Memory Map	8
4.4 Display Commands	9
4.5 Display Commands (continue)	10
5. Design and Handling Precaution	11

1. Basic Specifications

1.1 Display Specifications

- 1) LCD Display Mode : FSTN,Positive, Transflective
- 2) Display Color : Display Data = "1" : Dark Blue (*1)
: Display Data = "0" : Light Gray (*2)
- 3) Viewing Angle : 6H
- 4) Driving Method : 1/65 duty, 1/9 bias
- 5) Backlight : White LED backlight

Note:

*1. Color tone may slightly change by Temperature and Driving Condition.

*2. The Color is defined as the inactive / background color

1.2 Mechanical Specifications

- 1) Outline Dimension : 59.6 x 50.6 x 8.7MAX (mm)
(See attached Outline Drawing for details)

1.3 Block Diagram

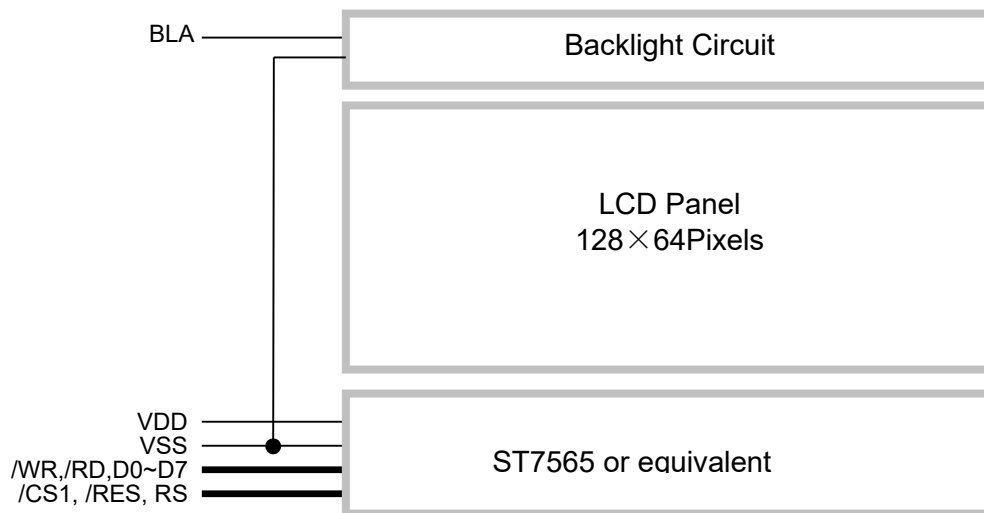

1.4 Terminal Functions

Pin No.	PIN Name	I/O	Descriptions
1	VSS	Power	Negative power supply,0V
2	VDD	Power	Positive power supply
3	DB7	I/O	8-bit Data bus; Three state I/O terminal for display data or instruction data When /CS =H; DB0~DB7=High Impedance
:	:		
10	DB0		
11	/RD	Input	Read enable input, active LOW
12	/WR	Input	Write enable input, active LOW
13	RS	Input	Register Select RS = H, Transferring the Display Data RS = L, Transferring the Control Data
14	/RES	Input	Reset signal /RES = L, Initialization is executed /RES = H, Normal running.
15	/CS1	Input	Chip Select /CS1=L, enable access to the LCD module /CS1=H, disable access to the LCD module
16	BLA	Power	Positive power for LED backlight

2. Absolute Maximum Ratings

Items	Symbol	Min.	Max.	Unit	Condition
Supply Voltage	V_{DD}	-0.3	+3.4	V	$V_{SS} = 0V$
Input Voltage	V_{IN}	-0.3	$V_{DD}+0.3$	V	$V_{SS} = 0V$
Operating Temperature	T_{OP}	-20	+70	°C	No Condensation
Storage Temperature	T_{ST}	-30	+80	°C	No Condensation

Cautions:

Any Stresses exceeding the Absolute Maximum Ratings may cause substantial damage to the device. Functional operation of this device at other conditions beyond those listed in the specification is not implied and prolonged exposure to extreme conditions may affect device reliability.

3. Electrical Characteristics

3.1 DC Characteristics

$V_{SS}=0V, V_{DD}=3.3V, T_{OP}=25^{\circ}C$

Items	Symbol	MIN.	TYP.	MAX.	Unit	Condition / Application Pin
Operating Voltage	V_{DD}	2.9	3.3	3.4	V	VDD
Input High Voltage	V_{IH}	$0.8 \times V_{DD}$	-	V_{DD}	V	/RES, /CS1, RS,
Input Low Voltage	V_{IL}	V_{SS}	-	$0.2 \times V_{DD}$	V	D0~D7, /WR, /RD
Operating Current	I_{DD}	-	0.15	1.4	mA	VDD

3.2 LED Backlight Circuit Characteristics

$V_{SS}=0V, I_{f_{BLA}}=39mA, T_{OP} = 25^{\circ}C$

Items	Symbol	MIN.	TYP.	MAX.	Unit	Applicable Pin
Forward Voltage	$V_{f_{BLA}}$	-	3.3	-	V	BLA
Forward Current	$I_{f_{BLA}}$	-	39	60	mA	BLA

Cautions:

Exceeding the recommended driving current could cause substantial damage to the backlight and shorten its lifetime.

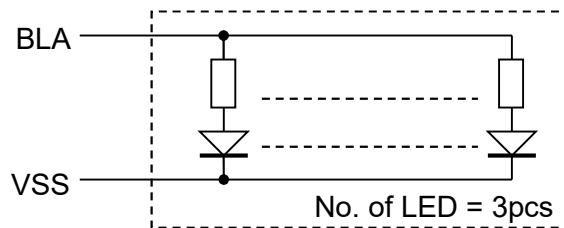

3.3 AC Characteristics

3.3.1 8080 Mode System Bus Timing

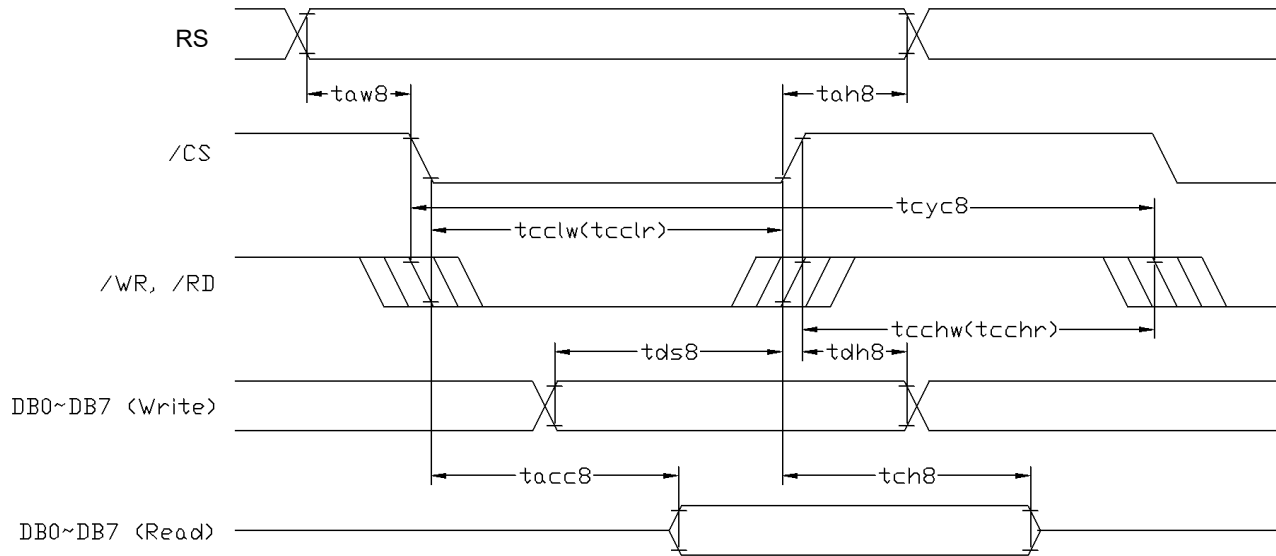

$V_{SS}=0V, V_{DD}=3.0V, T_{OP}=25^{\circ}C$

Item	Symbol	MIN.	TYP.	MAX.	Unit
System cycle time	tcyc8	240	-	-	ns
Address setup time (RS)	taw8	0	-	-	ns
Address hold time (RS)	tah8	0	-	-	ns
Control LOW pulse width (/WR)	tcclw	80	-	-	ns
Control LOW pulse width (/RD)	tcclr	140	-	-	ns
Control HIGH pulse width (/WR)	tcchw	80	-	-	ns
Control HIGH pulse width (/RD)	tcchr	80	-	-	ns
Data setup time	tds8	40	-	-	ns
Data hold time	tdh8	0	-	-	ns
/RD access time (*2)	tacc8	-	-	70	ns
Output disable time (*2)	tch8	-	5	50	ns

Note:

*1. Input signal rise/fall time should be less than 15ns .

*2. CL=100pF

*3.All timing is using 20% and 80% of VDD as the reference.

3.3.2 Reset Timing

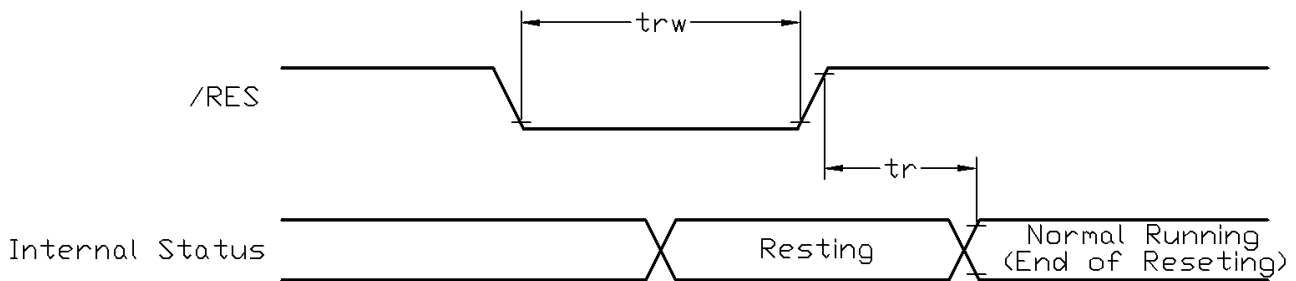

$V_{SS}=0V, V_{DD}=3.0V, T_{OP}=25^{\circ}C$

Item	Symbol	MIN.	TYP.	MAX.	Unit
Reset time	tr	-	-	2.5	μs
Reset LOW pulse width	trw	2.5	-	-	μs

Note:

*1.All timing is using 20% and 80% of VDD as the reference.

4. Function specifications

4.1 Basic Setting

To drive the LCD module correctly and provide normally display, please use the following setting

- ADC = 0 (normal)
- SHL select = 1 (reverse)
- LCD Bias Select = 1/9
- Initial Display Line = 0
- Entire Display ON/OFF = OFF (normal)
- Reverse Display ON/OFF = OFF (normal)
- Set Power Control Set:
voltage follower = ON, voltage converter = ON, voltage regulator = ON
- Display ON/OFF = ON

Note:

*1. These setting/commands should issue the LCD module while start up.

*2. See the Display Commands section for details.

4.2 Resetting the LCD module

The LCD module should be initialized by using /RES terminal.

While turning on the VDD and VSS power supply, maintain /RES terminal at LOW level. After the power supply stabilized, release the reset terminal (/RES=HIGH)

4.3 Display Memory Map

Page address	data	LCD Display (front view)	
0	D0 : D7	128x64 pixels	
1	D0 : D7		
2	D0 : D7		
3	D0 : D7		
4	D0 : D7		
5	D0 : D7		
6	D0 : D7		
7	D0 : D7		
Column Address		00h	→ 7Fh

Note:

- *1. ADC = 0 (normal)
- *2. SHL Selection = 1 (reverse)
- *3. Initial Display Line = 0

4.4 Display Commands

No.	Instructions	Code											Function
		RS	/RD	/WR	D7	D6	D5	D4	D3	D2	D1	D0	
1	Display ON/OFF	0	1	0	1	0	1	0	1	1	1	DON	DON=0, display off DON=1, display on
2	Display start line set	0	1	0	0	1	Display start address						Sets the display RAM display start line address
3	Set Page Address	0	1	0	1	0	1	1	Page Address				Set the display RAM page address
4	Set Column Address (Upper-4-bits)	0	1	0	0	0	0	1	Col. Add. Upper				Set the upper-4-bit of column address counter
	Set Column Address (Lower-4-bits)	0	1	0	0	0	0	0	Col. Add. Lower				Set the lower-4-bit of column address counter
5	Read Status	0	0	1	Status				0	0	0	0	Read the status data
6	Write Display Data	1	1	0	Write Data								Write data into the display RAM
7	Read Display Data	1	0	1	Read Data								Read data form the display RAM
8	ADC Select	0	1	0	1	0	1	0	0	0	0	ADC	Sets the display RAM address SEG output correspondence ADC= 0,normal . ADC=1, reverse
9	Normal/Reverse Display	0	1	0	1	0	1	0	0	1	1	REV	REV=0, Normal display REV=1, Reverse display
10	Entire Display ON/OFF	0	1	0	1	0	1	0	0	1	0	EON	EON=0, Normal display EON=1, Entire display ON
11	Set LCD Bias	0	1	0	1	0	1	0	0	0	1	BIAS	Set the LCD driving voltage bias BIAS=0, 1/9 BIAS BIAS=1, 1/7 BIAS
12	Set Read-Modify-Write	0	1	0	1	1	1	0	0	0	0		Enter the "Read-Modify-Write" mode column address counter will increase in each "Write Display Data", and will not increase in each "Read Display Data command"
13	Reset Read-Modify-Write	0	1	0	1	1	1	0	1	1	1	0	Clear the "Read-Modify-Write" mode
14	Reset	0	1	0	1	1	1	0	0	0	1	0	Resets the LCD module
15	SHL Select	0	1	0	1	1	0	0	SHL	*	*	*	Set the COM scanning direction SHL=0, Normal display SHL=1, Flipped in y direction * = don't care terms
16	Power Control Set	0	1	0	0	0	1	0	1	VC	VR	VF	Set the power circuit operation mode VF: LCD Supply Voltage Follower VR: LCD Supply Voltage Regulator VC: LCD Supply Voltage Converter (1=ON, 0=OFF)
17	Regulator Resistor Select	0	1	0	0	0	1	0	0	Radio setting			Set the built-in resistor ratio (Rb/Ra)

4.5 Display Commands (continue)

No.	Instructions	Code										Function	
		RS	/RD	/WR	D7	D6	D5	D4	D3	D2	D1		D0
18	Electronic volume mode set	0	1	0	1	0	0	0	0	0	0	1	Set reference voltage mode
	Electronic volume register set	0	1	0	*	*	Electronic Control value					Set reference voltage register (Display contrast value)	
19	Sleep Mode Set	0	1	0	1	0	1	0	1	1	0	S	Sleep Mode (2 byte command) S=0, sleep mode S=1, normal mode
		0	1	0	0	0	0	0	0	0	0	0	
20	Booster Ratio Set	0	1	0	1	1	1	1	1	0	0	0	Booster Ratio (2 byte command) Ratio=00, 2x, 3x, 4x
		0	1	0	0	0	0	0	0	0	0	Ratio	Ratio=01, 5x Ratio=11, 6x
21	NOP	0	1	0	1	1	1	0	0	0	1	1	Non-operation command

Note: *1. Do not use any other command not listed, or the system malfunction may result.
*2. For the details of the Display Commands, please refer to ST7565R data sheet.

4.5.1 Power off the LCD Module

It recommends that enter Sleep Mode before power off the LCD module.

4.5.2 Refreshing The LCD Module

It recommends that the operating modes and display contents be refreshed periodically to prevent the effect of unexpected noise.

5. Design and Handling Precaution

Please refer to "LCD-Module-Design-Handling-Precaution.pdf".

Terminal No.	Pin Name
1	VSS
2	VDD
3	DB7
4	DB6
5	DB5
6	DB4
7	DB3
8	DB2
9	DB1
10	DB0
11	/RD
12	/wR
13	RS
14	/RES
15	/CS1
16	BLA

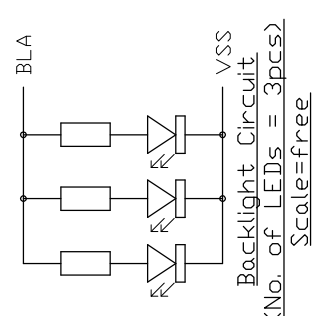
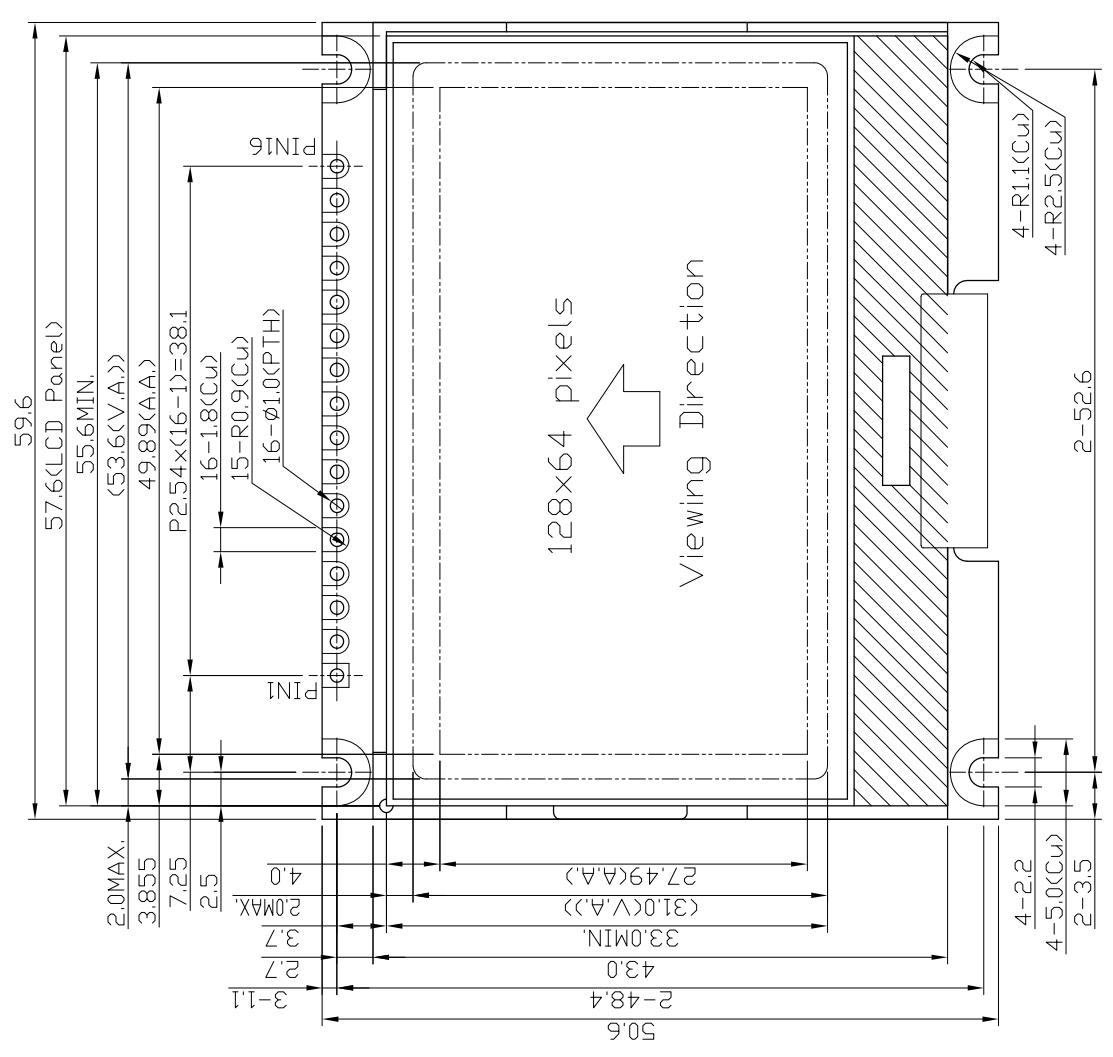
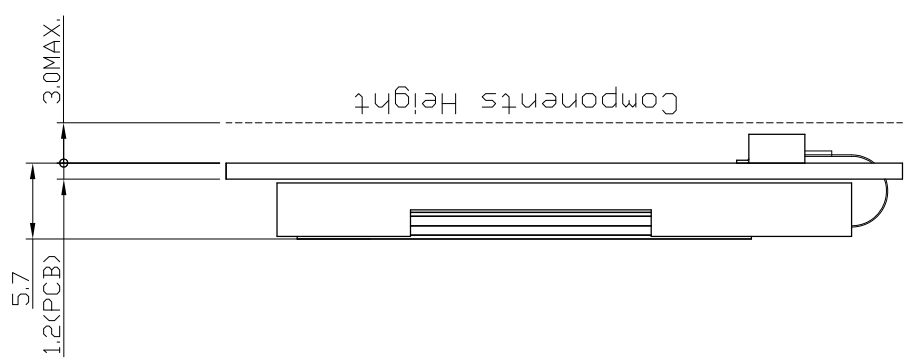
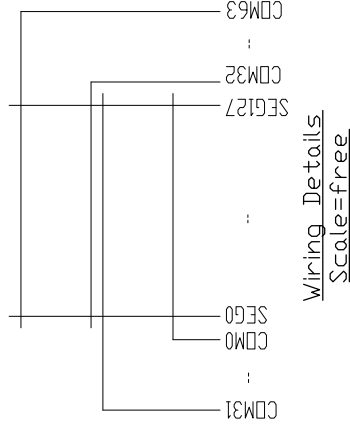
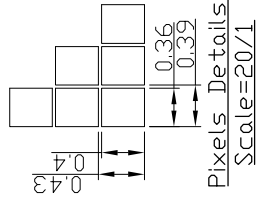

- Note:
- *1. Display Type : FSTN, Positive, Transflective
 - *2. Viewing Direction : 6H
 - *3. Duty : 1/65, Bias : 1/9
 - *4. Backlight Color : White
 - *5. Backlight Supply : 39mA(3.3V TYP.)
 - *6. Operating Voltage : 3.3V
 - *7. Operating Temperature : -20°C~70°C
 - *8. Storage Temperature : -30°C~80°C
 - *9. Environmental Safe Standard : RoHS

C	
B	
A	Revise Top,Tst
Rev/Note	
Dwg Title LM6029ACW Outline Dwg	
Dwg No.	MK-002552a-1-1
Date	2008-07-22
Scale	5/2
Tol.	±0.5
Unit	mm
Paper Size	A3
Checked	
Drawn	David Yuan

TOPWAY