



深圳市拓普微科技开发有限公司
SHENZHEN TOPWAY TECHNOLOGY CO., LTD.

LMT043DNFFWD-NCN

LCD Module User Manual

Prepared by: Li Keke Date: 2021-07-23	Checked by: Date:	Approved by: Date:
--	----------------------------------	-----------------------------------

Rev.	Descriptions	Release Date
0.1	New release	2019-08-29
0.2	add SPI Mode Timing	2021-07-23

Table of Content

1. GENERAL SPECIFICATION.....	3
2. BLOCK DIAGRAM.....	3
3. TERMINAL FUNCTIONS.....	4
4. ABSOLUTE MAXIMUM RATINGS.....	4
5. ELECTRICAL CHARACTERISTICS.....	5
5.1 DC CHARACTERISTICS.....	5
6. AC CHARACTERISTICS.....	5
6.1 8080 MODE TIMING.....	5
6.2 SPI MODE TIMING.....	6
6.3 RESET TIMING.....	8
7. OPTICAL CHARACTERISTICS.....	8
8. FUNCTION SPECIFICATIONS.....	10
8.1 COMMAND SUMMARY.....	10
9. LCD MODULE DESIGN AND HANDLING PRECAUTIONS.....	13
10. CTP MOUNTING INSTRUCTIONS.....	14
11. RTP MOUNTING INSTRUCTIONS.....	15

1. General Specification

Screen Size(Diagonal) :	4.3 inch
Resolution :	480(RGB) x 272
Interface :	8bit MCU Interface
Color Depth :	16.7M color (24bit)
Dot Pitch :	0.198 x 0.198 (mm)
Pixel Configuration :	RGB Stripe
Display Mode :	Transmissive / Positive
Surface Treatment :	Anti-Glare Treatment
Viewing Direction :	12 o'clock (gray scale inverse)
Outline Dimension :	121.0x70.0x12.2 (mm)
Active Area :	95.4 x 53.86 (mm)
Backlight :	LED, White
Operating Temperature :	-20 ~ +70°C
Storage Temperature :	-30 ~ +80°C

Note: Backlight color may slightly change over temperature and driving voltage.

2. Block Diagram

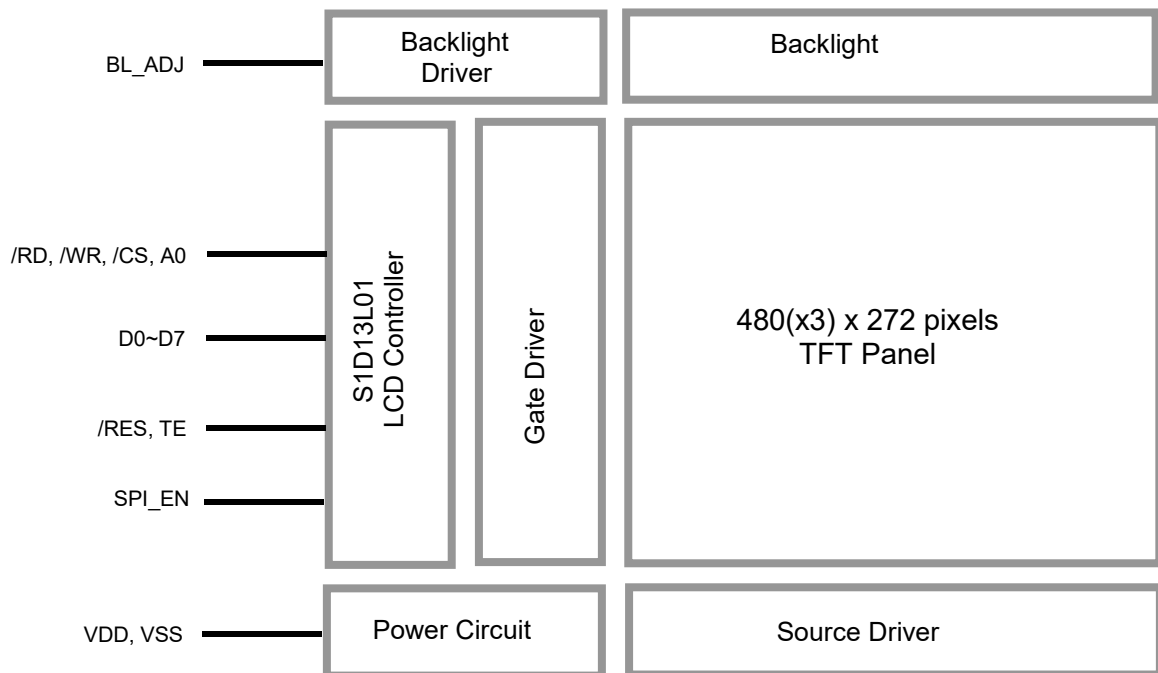

3. Terminal Functions

Terminal (K1)

Pin No.	Pin Name	I/O	8bit MCU Mode (Default) Description	SPI Mode Description
1	VSS	Power Input	Power Supply GND (0V)	
2				
3	VDD	Power Input	Positive Power Supply(3.3V)	
4				
5	A0	Input	Access Mode A0=High: Accessing Data A0=Low: Accessing Address	Keep open
6	/CS	Input	Chip Select /CS=Low: Data IO is enabled	
7	/RES	Input	Reset /RES=Low: Reset /RES=High: Normal operation	
8	D0(SI)	Bi-directional I/O	8-bit Bi-directional data bus	Serial input
9	D1(SO)			Serial output
:	:			Keep open
14	D6			Keep open
15	D7			Keep open
16	TE	Output	TE Signal	
17	/RD	Input	Read Enable, active Low	Keep open
18	/WR(SCK)	Input	Write Enable, active Low	Serial clock
19	BL_ADJ	Input	Backlight Driver enable signal, active High, PWM(*2)can be possible	
20	SPI_EN	Input	Keep open	SPI Enable, active high
21	NC	-	No connection	
22	NC	-	No connection	
23	NC	-	No connection	
24	NC	-	No connection	
25	NC	-	No connection	
26	NC	-	No connection	

Note.

*1. Tear signal may leave open when not use

*2. The PWM frequency is between 200Hz and 500Hz.

*3. Pulled-up by internal resistor

4. Absolute Maximum Ratings

Items	Symbol	Min.	Max.	Unit	Condition
Supply Voltage	V _{DD}	-0.2	3.7	V	V _{SS} = 0V
Input Voltage	V _{IN}	-0.2	3.7	V	V _{SS} = 0V
Operating Temperature	T _{OP}	-20	+70	°C	No Condensation
Storage Temperature	T _{ST}	-30	+80	°C	No Condensation

Caution:

Any Stresses exceeding the Absolute Maximum Ratings may cause substantial damage to the device. Functional operation of this device at other conditions beyond those listed in the specification is not implied and prolonged exposure to extreme conditions may affect device reliability.

5. Electrical Characteristics

5.1 DC Characteristics

$V_{SS}=0V, V_{DD}=3.3V, T_{OP}=25^{\circ}C$

Items	Symbol	MIN.	TYP.	MAX.	Unit	Applicable Pin
Operating Voltage	V_{DD}	2.8	3.3	3.6	V	VDD
Input High Voltage	V_{IH}	-	-	VDD	V	Input pins, Bi-direction pins
Input Low Voltage	V_{IL}	VSS	-	-	V	Input pins, Bi-direction pins
Output High Voltage	V_{OH}	2.6	-	-	V	Bi-direction pins (*1)
Output Low Voltage	V_{OL}	-	-	0.6	V	Bi-direction pins (*2)
Operating Current	I_{DD}	-	230	500	mA	On Backlight Power on status

Note:

- *1. Never Apply logic signal before the VDD supply.
- *2. VDD setting should match the signals voltage

6. AC Characteristics

6.1 8080 Mode Timing

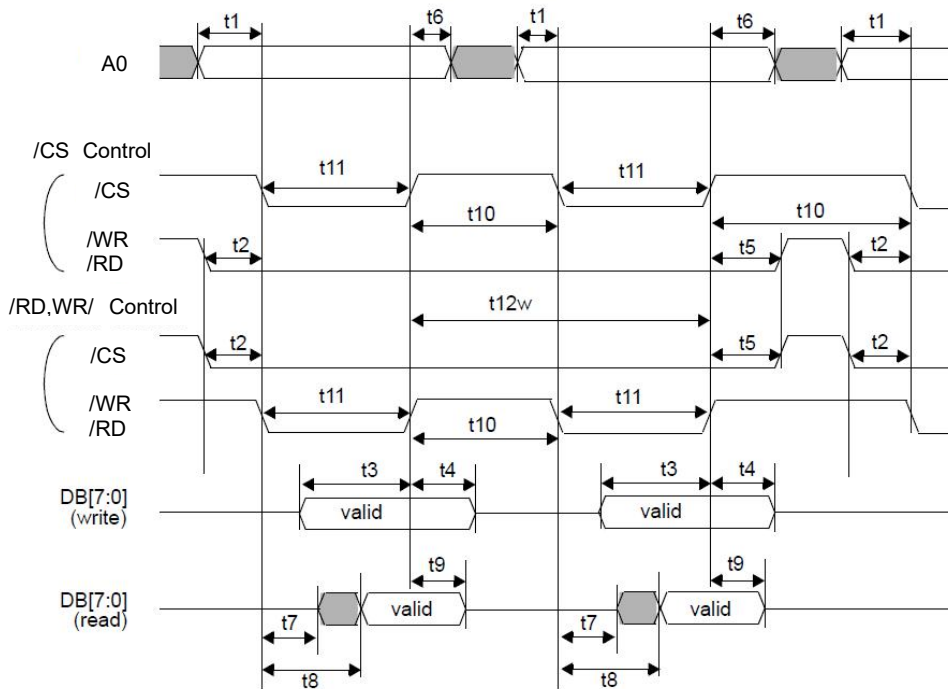

Figure 2

Symbol	Parameter	3.3 Volt		Units
		Min	Max	
t1	A0 setup time to /CS (/WR, /RD)	1	-	ns
t2	/WR, /RD (/CS) setup time to /CS (/WR, /RD)	1	-	ns
t3	DB[7:0] setup time to /CS (/WR) rising edge: write cycle	1	-	ns
t4	DB[7:0] hold time from /CS (/WR) rising edge: write cycle	7	-	ns
t5w	/WR (/CS) hold time from /CS (/WR) rising edge: write cycle	3	-	ns
t5r	/RD (/CS) hold time from /CS (/RD) rising edge: read cycle	0	-	ns
t6	A0 hold time from /CS (/WR, /RD) rising edge	4	-	ns
t7	/CS (/RD) falling edge to DB[7:0] driven: read cycle	-	15	ns
t8	/CS (/RD) falling edge to valid Data: read cycle	-	4xTmclk+17	ns
t9	DB[7:0] hold time from /CS (/RD) rising edge: read cycle	2	12	ns
t10w	End of write to next read/write	5	-	ns
t10r	End of read to next read/write	Tmclk+9	-	ns
t11w	/CS (/WR) pulse width for write cycle	3	-	ns
t12w	/CS (/WR) rise to next /CS (/WR) rise: write cycle	3xTmclk+6	-	ns

- Note: 1. Tmclk = period of internal MCLK clock signal.
 2. Please refer to S1D13L01 datasheet for details

Indirect 8-bit Function Select:

A0	/WR	/RD	Comments
0	0	1	Command Write (register address)
1	0	1	Data (Parameter) Write
0	1	0	inhibit
1	1	1	Data (Parameter) Read

6.2 SPI Mode Timing

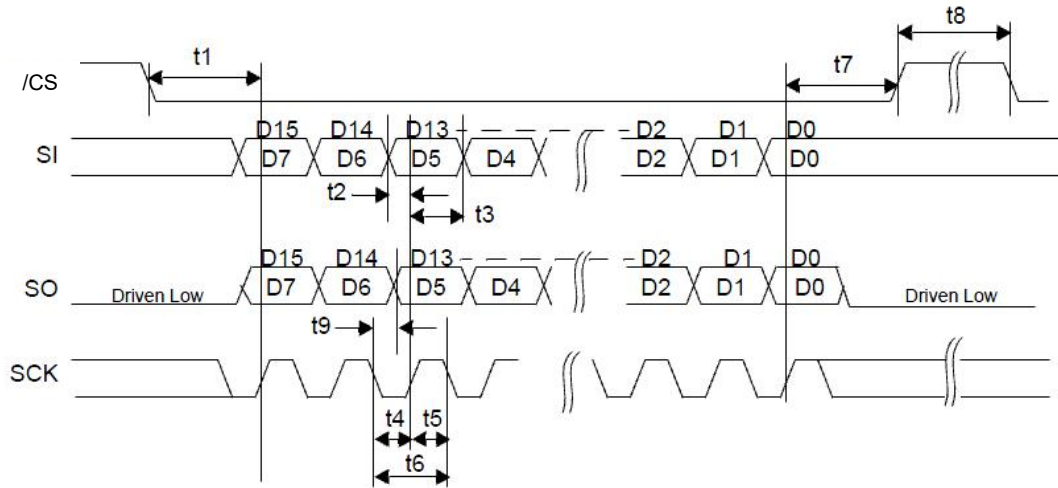

Symbol	Parameter	3.3 Volt		Units
		Min	Max	
t1	Chip select setup time	2	-	ns
t2	SI Data setup time	1	-	ns
t3	SI Data hold time	7	-	ns
t4	Serial clock pulse width low (high)	15	-	ns
t5	Serial clock pulse width high (low)	15	-	ns
t6	Serial clock period	30	-	ns
t7	Chip select hold time	7	-	ns
t8	Chip select de-assert to reassert	2	-	ns
t9	SCK falling edge to SO hold time	3	10	ns

Note: 1. $C_L = 10pF$ for SPI timing.
 2. Please refer to S1D13L01 datasheet for details.
 3. SPI Function Select

Command	Comments
10000000	8-bit Write
11000000	8-bit Read
10001000	16-bit Write
11001000	16-bit Read
the other	reserved

Write Procedure:
SPI 8bit Write Sequence:

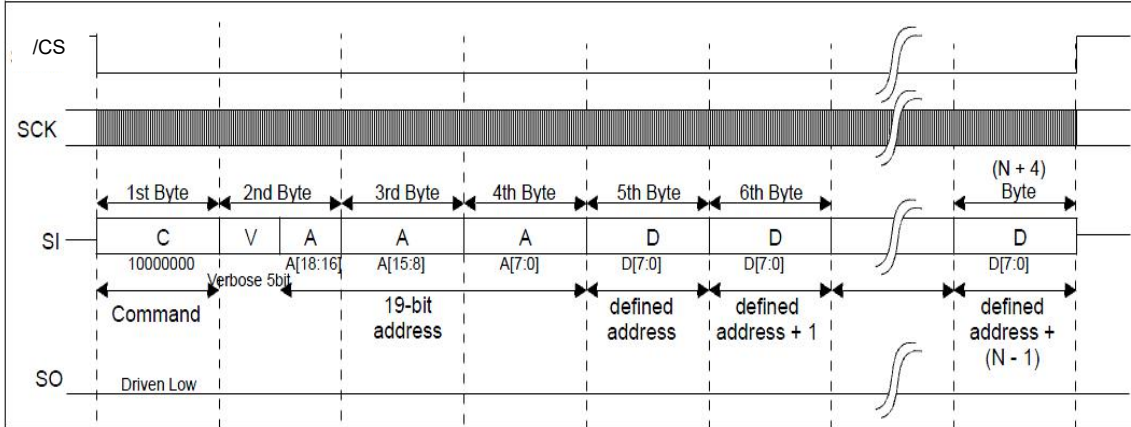

SPI 16bit Write Sequence:

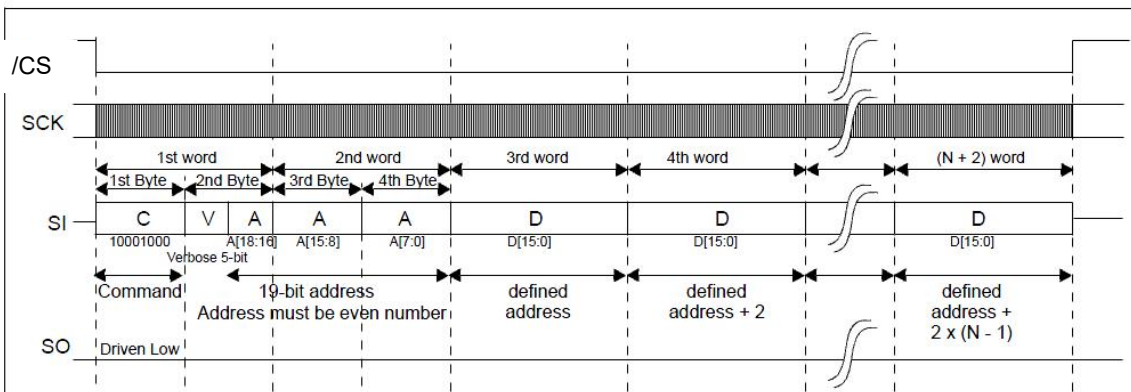

Read Procedure:
SPI 8bit Read Sequence:

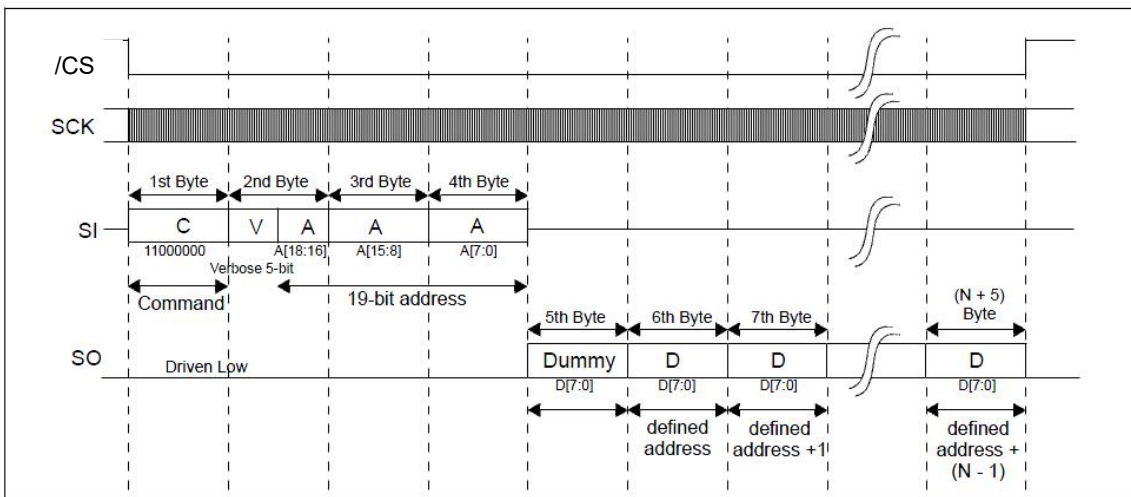

SPI 16bit Read Sequence:

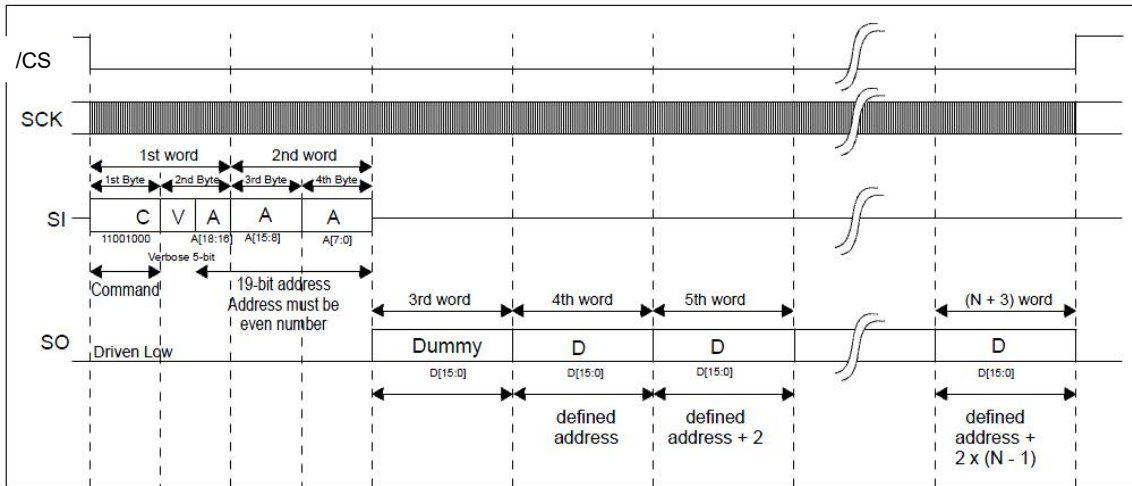

Please refer to S1D13L01 datasheet for details.

6.3 Reset Timing

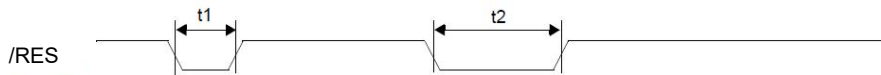

Figure 8

Symbol	Parameter	Min	Max	Units
t1	Reset Pulse Width is ignored	-	42	ns
t2	Active Reset Pulse Width (see Note)	150	-	ns

Note: The Reset input should be held low for longer than 150ns to guarantee reset. For more information and details please refer to LCD controller (S1D13L01) datasheet.

7. Optical Characteristics

Item	Symbol	Condition	MIN.	TYP.	MAX.	UNIT	Note.	
Viewing angle	θ_T	(CR \geq 10)	60	70	-	degree	Note 2	
	θ_B		40	50	-			
	θ_L		60	70	-			
	θ_R		60	70	-			
Contrast ratio	CR	$\theta=0^\circ$	400	500	-	-	Note 1,3	
Response Time	T_{on}	25°C	-	20	30	msec	Note 1,4	
	T_{off}		-	-	-	msec		
Chromaticity	White	Backlight is on	X	0.265	0.315	0.365		Note 1,5
			Y	0.285	0.335	0.385		
	Red		X	0.531	0.581	0.631		
			Y	0.295	0.345	0.395		
	Green		X	0.298	0.348	0.395		
			Y	0.531	0.581	0.631		
	Blue		X	0.103	0.153	0.203		
			Y	0.045	0.095	0.145		
NTSC			-	50		%	Note 5	
Luminance uniformity	U		-	75	-	%	Note 1,7	
Luminance	L			400	-	cd/m ²		

Note:

The parameter is slightly changed by temperature, driving voltage and material
Please see the Notes for testing conditions

Note 1:

The data are measured after LEDs are turned on for 5 minutes. LCM displays full white. The brightness is the average value of 9 measured spots. Measurement equipment PR-705 (Φ8mm)

Measuring condition:

- Measuring surroundings: Dark room
- Measuring temperature: Ta=25°C.
- Adjust operating voltage to get optimum contrast at the center of the display.

Measured value at the center point of LCD panel after more than 5 minutes while backlight turning on.

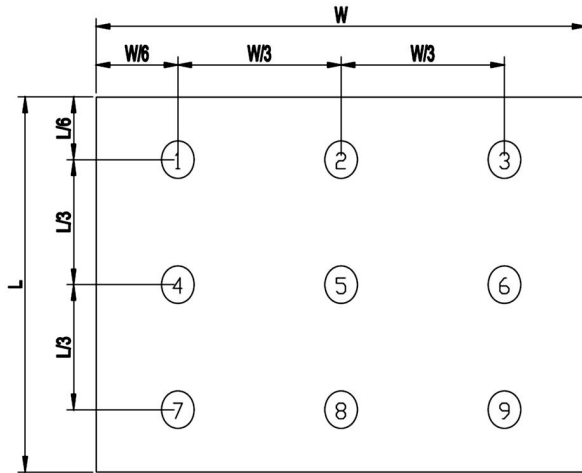

Figure 9

Note 2: reference Figure5

The luminance uniformity is calculated by using following formula.

$$\Delta Bp = Bp (\text{Min.}) / Bp (\text{Max.}) \times 100 (\%)$$

Bp (Max.) = Maximum brightness in 9 measured spots

spots

Bp (Min.) = Minimum brightness in 9 measured spots.

Note 3: reference Figure6

The definition of viewing angle:
Refer to the graph below marked by θ and ϕ

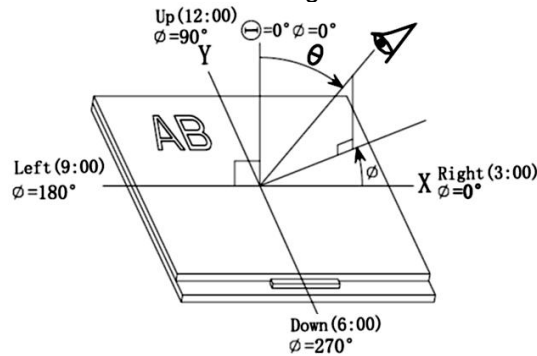

Figure 10

Note 4:

The definition of contrast ratio (Test LCM using PR-705):

$$\text{Contrast Ratio (CR)} = \frac{\text{Luminance When LCD is at "White" state}}{\text{Luminance When LCD is at "Black" state}}$$

(Contrast Ratio is measured in optimum common electrode voltage)

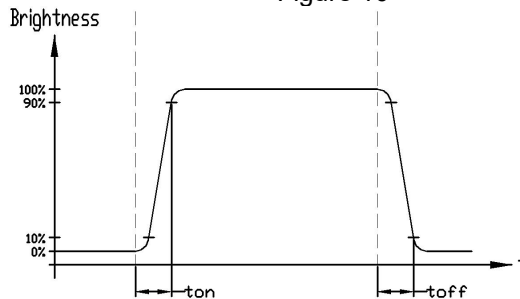

Figure 11

Note 5: reference Figure7

Definition of Response time. (Test LCD using DMS501):

The output signals of photo detector are measured when the input signals are changed from "black" to "white"(falling time) and from "white" to "black"(rising time), respectively.

The response time is defined as the time interval between the 10% and 90% of amplitudes. Refer to figure as below.

Note 6: reference Figure8

Definition of Color of CIE Coordinate and NTSC Ratio.

Color gamut:

$$S = \frac{\text{Area of RGB triangle}}{\text{Area of NTSC triangle}} \times 100\%$$



Figure 12

8. Function Specifications

8.1 Command Summary

Command	Parameter	HEX	A0	/CS	/WR	D7	D6	D5	D4	D3	D2	D1	D0	Descriptions
Power Save	P1	60804	0	0	0	A[7:0]-> A[15:8] -> A[18:16]							Power Save Configuration Register	
	P2	D[7:0]	1	0	0	n/a	n/a	n/a	n/a	n/a	n/a	n/a	n/a	Power Save
Software Reset		P1	60806	0	0	0	A[7:0]-> A[15:8] -> A[18:16]							Software Reset Register(Write Only)
	P2	D[7:0]	1	0	0	n/a	n/a	n/a	n/a	n/a	n/a	n/a	n/a	Software Reset Bit[8] = 0 , no effect in hardware Bit[8] = 1 , all registers are reset to default values
PLL Setting 0	P1	60810	0	0	0	A[7:0]-> A[15:8] -> A[18:16]							PLL Setting Register 0	
	P2	D[7:0]	1	0	0	n/a	n/a	n/a	n/a	n/a	n/a	PLL Bypass	PLL Enable	Bit[0] = 0 , the PLL is disabled Bit[0] = 1 , the PLL enabled Bit[1] = 0 , PLL is selected Bit[1] = 1 , CLKI is selected Bit[15] = 0 , the PLL output is not stable Bit[15] = 1 , the PLL output is stable
PLL Setting 1		P1	60812	0	0	0	A[7:0]-> A[15:8] -> A[18:16]							PLL Setting Register 1
	P2	D[7:0]	1	0	0	M-Divider				N-Counter			M-Divider	Bit[9:0] 000h,001h 019h,020h : 1:1 ,2:1 33:1(M-Divide Ratio). 021h to 13Fh: Reserved, PFDCLK = CLKI + (M-Divider + 1) Bit[13:10] , must be set to 0000
PLL Setting 2	P1	60814	0	0	0	A[7:0]-> A[15:8] -> A[18:16]							PLL Setting Register 2	
	P2	D[7:0]	1	0	0	L-Counter				L-Counter			Bit[9:0] , must be set between 010h ~ 041h. , and get the M-Divide Ratio from 17:1 to 66:1. POCLK = (L-Counter + 1) x (N-Counter + 1) x PFDCLK	
Internal Clock Configuration	P1	60816	0	0	0	A[7:0]-> A[15:8] -> A[18:16]							Internal Clock Configuration Register	
	P2	D[7:0]	1	0	0	n/a	n/a	n/a	n/a	n/a	n/a	n/a	n/a	Bit[3:0] = 0000b,0001b 1110b,1111b : 1:1 ,2:1 16:1(MCLK to PCLK Frequency Ratio)
Panel Setting Miscellaneous	P1	60820	0	0	0	A[7:0]-> A[15:8] -> A[18:16]							Panel Setting Miscellaneous Register	
	P2	D[7:0]	1	0	0	DE Polarity	PCLK Polarity	n/a	Panel Data Enable	Panel Data Width	Panel Port Enable	Bit[0] = 0 , TFT panel is disable Bit[0] = 1 , TFT panel is enable Bit[2:1] = 01 , TFT 16-bit Bit[2:1] = 10 , TFT 18-bit Bit[2:1] = 11 , TFT 24-bit Bit[3] = 0 , panel data is disable Bit[3] = 1 , panel data is enable Bit[5] = 0 , the LCD data outputs transition on the rising edge of PCLK Bit[5] = 1 , the LCD data outputs transition on the falling edge of PCLK Bit[7:6] = 00 , DE Polarity Low active Bit[7:6] = 01 , DE Polarity High active Bit[7:6] = 10 , DE Polarity Fixed to Low Bit[7:6] = 11 , DE Polarity Fixed to High		
Display Settings	P1	60822	0	0	0	A[7:0]-> A[15:8] -> A[18:16]							Display Settings Register	
	P2	D[7:0]	1	0	0	TE Status (RO)	TE Function	Display Blank	n/a	Display Blank Polarity	SW Video Invert	Panel Interface Enable	TE Output Pin Disable	Bit[0] = 0 , HS, VS, DE and PCLK are fixed to H or L and the display pipes are disabled Bit[0] = 1 , enable the panel output and display pipes Bit[1] = 0 , video data is normal Bit[1] = 1 , video data is inverted Bit[2] = 0 , the display blank function operates normally Bit[2] = 1 , the display blank function switches polarity Bit[4] = 0 , the LCD data is masked Bit[4] = 1 , all applicable LCD data outputs are forced to zero or one Bit[6:5] = 00b , TE output is disabled and the pin output is low Bit[6:5] = 01b , TE output is high (1) when the display is in the Vertical Non-Display Period (VNDP) and low (0) when the display is in Vertical Display Period (VDISP) Bit[6:5] = 10b , Line Count Bit[6:5] = 11b , Reserved Bit[7] = 0 , the selected condition in not occurring Bit[7] = 1 , the selected condition in not occurring Bit[8] = 0 , TE is output Bit[8] = 1 , TE is not output
HDISP	P1	60824	0	0	0	A[7:0]-> A[15:8] -> A[18:16]							Horizontal Display Width Register (HDISP)	
	P2	D[7:0]	1	0	0	n/a	Horizontal Display Width						Bit[6:0] = horizontal display width in pixels + 8	
HNDP	P1	60826	0	0	0	A[7:0]-> A[15:8] -> A[18:16]							Horizontal Non-Display Period Register (HNDP)	
	P2	D[7:0]	1	0	0	n/a	Horizontal Non-Display Period						Bit[6:0] = horizontal non-display period in PCLK's	
VDISP	P1	60828	0	0	0	A[7:0]-> A[15:8] -> A[18:16]							Vertical Display Height Register (VDISP)	
	P2	D[7:0]	1	0	0	Vertical Display Height						Vertical Display Height	Bit[9:0] = vertical display height in lines	
VNDP	P1	6082A	0	0	0	A[7:0]-> A[15:8] -> A[18:16]							Vertical Non-Display Period Register (VNDP)	
	P2	D[7:0]	1	0	0	Vertical Non-Display Period						Bit[7:0] = vertical non-display period in lines		

		D[15:8]	1	0	0	n/a	n/a	n/a	n/a	n/a	n/a	n/a	n/a	n/a
--	--	---------	---	---	---	-----	-----	-----	-----	-----	-----	-----	-----	-----

Command	Parameter	HEX	A0	/CS	/WR	D7	D6	D5	D4	D3	D2	D1	D0	Descriptions	
HSW	P1	6082C	0	0	0	A[7:0]-> A[15:8] -> A[18:16]								HS Pulse Width Register (HSW)	
	P2	D[7:0]	1	0	0	HS Pulse Polarity	HS Pulse Width							Bit[6:0] = HS pulse width in PCLK's Bit[7] = 0 , the horizontal sync signal is active low Bit[7] = 1 , the horizontal sync signal is active high	
		D[15:8]	1	0	0	n/a	n/a	n/a	n/a	n/a	n/a	n/a	n/a	n/a	
HPS	P1	6082E	0	0	0	A[7:0]-> A[15:8] -> A[18:16]								HS Pulse Start Position Register (HPS)	
	P2	D[7:0]	1	0	0	HS Pulse Start Position							Bit[6:0] = HS pulse start position in PCLK's		
		D[15:8]	1	0	0	n/a	n/a	n/a	n/a	n/a	n/a	n/a	n/a	n/a	
VSW	P1	60830	0	0	0	A[7:0]-> A[15:8] -> A[18:16]								VS Pulse Width Register (VSW)	
	P2	D[7:0]	1	0	0	VS Pulse Polarity	n/a	VS Pulse Width							Bit[5:0] = VS pulse width in lines Bit[7] = 0 , the vertical sync signal is active low Bit[7] = 1 , the vertical sync signal is active high
		D[15:8]	1	0	0	n/a	n/a	n/a	n/a	n/a	n/a	n/a	n/a	n/a	
VPS	P1	60832	0	0	0	A[7:0]-> A[15:8] -> A[18:16]								VS Pulse Start Position Register (VPS)	
	P2	D[7:0]	1	0	0	VS Pulse Start Position							Bit[7:0] = VS pulse start position in lines		
		D[15:8]	1	0	0	n/a	n/a	n/a	n/a	n/a	n/a	n/a	n/a	n/a	
TE Line Count	P1	60834	0	0	0	A[7:0]-> A[15:8] -> A[18:16]								TE Line Count Register	
	P2	D[7:0]	1	0	0	TE Line Count							TE Line Count	These bits specify the line count value that is compared with the internal vertical line counter	
		D[15:8]	1	0	0	n/a	n/a	n/a	n/a	n/a	n/a	n/a			n/a
Main Layer Setting	P1	60840	0	0	0	A[7:0]-> A[15:8] -> A[18:16]								Main Layer Setting Register	
	P2	D[7:0]	1	0	0	n/a	n/a	n/a	Main Layer Rotation Select	Main Layer Color Depth			Multi-Byte Layer Registers Synchronizing Latching Disable		
		D[15:8]	1	0	0	n/a	n/a	n/a	n/a	n/a	n/a	n/a		n/a	
Main Layer Start Address 0	P1	60842	0	0	0	A[7:0]-> A[15:8] -> A[18:16]								Main Layer Start Address Register 0	
	P2	D[7:0]	1	0	0	Main Layer Start Address							Bit[15:0] is Bit[15:0] of Main Layer Start Address ,but Bit[1:0] must be set to 00b		
		D[15:8]	1	0	0	Main Layer Start Address									
Main Layer Start Address 1	P1	60844	0	0	0	A[7:0]-> A[15:8] -> A[18:16]								Main Layer Start Address Register 1	
	P2	D[7:0]	1	0	0	n/a	Main Layer Start Address			Main Layer Start Address			Bit[2:0] is Bit[18:16] of Main Layer Start Address		
		D[15:8]	1	0	0	n/a	n/a	n/a	n/a	n/a	n/a	n/a		n/a	
Main Layer Width	P1	60846	0	0	0	A[7:0]-> A[15:8] -> A[18:16]								Main Layer Width Register	
	P2	D[7:0]	1	0	0	Main Layer Width							Main Layer Width	Read Only	
		D[15:8]	1	0	0	n/a	n/a	n/a	n/a	n/a	n/a	n/a			n/a
Main Layer Height	P1	60848	0	0	0	A[7:0]-> A[15:8] -> A[18:16]								Main Layer Height Register	
	P2	D[7:0]	1	0	0	Main Layer Height							Main Layer Height	Read Only	
		D[15:8]	1	0	0	n/a	n/a	n/a	n/a	n/a	n/a	n/a			n/a
PIP Layer Setting	P1	60850	0	0	0	A[7:0]-> A[15:8] -> A[18:16]								PIP Layer Setting Register	
	P2	D[7:0]	1	0	0	n/a	n/a	n/a	n/a	n/a	n/a	n/a	n/a	Bit[2:0] = 000b, RGB 8:8:8 (default) Bit[2:0] = 001b, RGB 5:6:5 Bit[2:0] = 010b/011b/111b, Reserved Bit[2:0] = 100b, 24 bpp + LUT1 Bit[2:0] = 101b, 16 bpp + LUT1 Bit[2:0] = 110b, 8 bpp + LUT1 Bit[4:3] = 00b, 0° (Normal) Bit[4:3] = 01b, 90° Bit[4:3] = 10b, 180° Bit[4:3] = 11b, 270°	
		D[15:8]	1	0	0	n/a	n/a	n/a	PIP Layer Rotation Select	PIP Layer Color Depth					
PIP Layer Start Address 0	P1	60852	0	0	0	A[7:0]-> A[15:8] -> A[18:16]								PIP Layer Start Address Register 0	
	P2	D[7:0]	1	0	0	PIP Layer Start Address							Bit[15:0] is Bit[15:0] of Main Layer Start Address ,but Bit[1:0] must be set to 00b		
		D[15:8]	1	0	0	PIP Layer Start Address									
PIP Layer Start Address 1	P1	60854	0	0	0	A[7:0]-> A[15:8] -> A[18:16]								PIP Layer Start Address Register 1	
	P2	D[7:0]	1	0	0	n/a	n/a	n/a	n/a	n/a	n/a	n/a	n/a	Bit[2:0] is Bit[18:16] of Main Layer Start Address	
		D[15:8]	1	0	0	n/a	n/a	n/a	n/a	n/a	PIP Layer Start Address				
PIP Layer Width	P1	60856	0	0	0	A[7:0]-> A[15:8] -> A[18:16]								PIP Layer Width Register	
	P2	D[7:0]	1	0	0	PIP Layer Width							PIP Layer Width	Bit[9:] = PIP Layer Horizontal Display Period in number of pixels PIP Layer Horizontal Display Period in number of pixels	
		D[15:8]	1	0	0	n/a	n/a	n/a	n/a	n/a	n/a	n/a			n/a

Command	Parameter	HEX	A0	/CS	/WR	D7	D6	D5	D4	D3	D2	D1	D0	Descriptions
PIP Layer Height	P1	60858	0	0	0	A[7:0]-> A[15:8] -> A[18:16]								PIP Layer Height Register
	P2	D[7:0] D[15:8]	1	0	0	PIP Layer Height							PIP Layer Height	Bit[9:] = PIP Layer Vertical Display Period in number of lines
PIP Layer X Start Position	P1	6085A	0	0	0	A[7:0]-> A[15:8] -> A[18:16]								PIP Layer X Start Position Register
	P2	D[7:0] D[15:8]	1	0	0	n/a	n/a	n/a	n/a	n/a	n/a	n/a	PIP Layer X Start Position	These bits specify X start position of the PIP Layer on the panel, in lines
PIP Layer Y Start Position	P1	6085C	0	0	0	A[7:0]-> A[15:8] -> A[18:16]								PIP Layer Y Start Position Register
	P2	D[7:0] D[15:8]	1	0	0	n/a	n/a	n/a	n/a	n/a	n/a	n/a	PIP Layer Y Start Position	These bits specify Y start position of the PIP Layer on the panel, in lines
PIP Enable	P1	60860	0	0	0	A[7:0]-> A[15:8] -> A[18:16]								PIP Enable Register
	P2	D[7:0] D[15:8]	1	0	0	n/a	n/a	n/a	n/a	Blink/Fade Status (RO)	Blink/Fade Effect		n/a	Bit[2:0] = 000b, Blank Bit[2:0] = 001b, Normal Bit[2:0] = 010b, Blink 1 Bit[2:0] = 011b, Blink 2 Bit[2:0] = 100b, Fade Out Bit[2:0] = 101b, Fade In Bit[2:0] = 110b, Fade In/Out Continuous Bit[2:0] = 111b, Reserved Bit[3] = 0b, the PIP layer is not blinking or fading Bit[3] = 1b, the PIP layer is in the process of blinking or fading Bit[15:9] = blink/fade period in frames - 1
Alpha Blending	P1	60862	0	0	0	A[7:0]-> A[15:8] -> A[18:16]								Alpha Blending Register
	P2	D[7:0] D[15:8]	1	0	0	n/a	Alpha Blending Ratio					Alpha Blending Step	Bit[6:0] = 0000000b,0000001b... 01111111b,10000000b : 64:0 (no PIP),63:1 1:63,0:64(full PIP) ; 1000001b ~ 1111111b : Reserved Bit[9:8] = 00b, 1 Bit[9:8] = 01b, 2 Bit[9:8] = 10b, 4 Bit[9:8] = 11b, 8	
Transparency	P1	60864	0	0	0	A[7:0]-> A[15:8] -> A[18:16]								Transparency Register
	P2	D[7:0] D[15:8]	1	0	0	n/a	n/a	n/a	n/a	n/a	n/a	n/a	Transparency Enable	Bit[0] = 0b, transparency is disabled Bit[0] = 1b, transparency is enabled
Transparency Key Color 0	P1	60866	0	0	0	A[7:0]-> A[15:8] -> A[18:16]								Transparency Key Color Register 0
	P2	D[7:0] D[15:8]	1	0	0	Key Color Blue							Key Color Green	Bit[15:8] is Key Color Green bits [7:0] Bit[7:0] is Key Color Blue bits [7:0]
Transparency Key Color 1	P1	60868	0	0	0	A[7:0]-> A[15:8] -> A[18:16]								Transparency Key Color Register 1
	P2	D[7:0] D[15:8]	1	0	0	n/a	n/a	n/a	n/a	n/a	n/a	n/a	n/a	Bit[7:0] is Key Color Red bits [7:0]
GPIO Configuration	P1	608D0	0	0	0	A[7:0]-> A[15:8] -> A[18:16]								GPIO Configuration Register
	P2	D[7:0] D[15:8]	1	0	0	GPIO7 Config	GPIO6 Config	GPIO5 Config	GPIO4 Config	GPIO3 Config	GPIO2 Config	GPIO1 Config	GPIO0 Config	Bit[15:0] = 0b (default), the corresponding GPIO pin is configured as an input pin Bit[15:0] = 1b , the corresponding GPIO pin is configured as an output pin
GPIO Status and Control	P1	608D2	0	0	0	A[7:0]-> A[15:8] -> A[18:16]								GPIO Status and Control Register
	P2	D[7:0] D[15:8]	1	0	0	GPIO7 Status	GPIO6 Status	GPIO5 Status	GPIO4 Status	GPIO3 Status	GPIO2 Status	GPIO1 Status	GPIO0 Status	When GPIOx is configured as an output: Bit[15:0] = 0b, GPIOx low Bit[15:0] = 1b, GPIOx high
GPIO Pull-Down Control	P1	608D4	0	0	0	A[7:0]-> A[15:8] -> A[18:16]								GPIO Pull-Down Control Register
	P2	D[7:0] D[15:8]	1	0	0	GPIO7 Pull-down Control	GPIO6 Pull-down Control	GPIO5 Pull-down Control	GPIO4 Pull-down Control	GPIO3 Pull-down Control	GPIO2 Pull-down Control	GPIO1 Pull-down Control	GPIO0 Pull-down Control	Bit[15:0] = 0b, the pull-down resistor for the associated GPIO pin is inactive. Bit[15:0] = 1b, the pull-down resistor for the associated GPIO pin is active.

Note: Access of PLL Setting 0, PLL Setting 1, PLL Setting 2 and Internal Clock Configuration is only possible in Power Save Mode PSM0.

For more information and details please refer to S1D13L01 datasheet.

9. LCD Module Design and Handling Precautions

- Please ensure V0, VCOM is adjustable, to enable LCD module get the best contrast ratio under different temperatures, view angles and positions.
- Normally display quality should be judged under the best contrast ratio within viewable area. Unexpected display pattern may come out under abnormal contrast ratio.
- Never operate the LCD module exceed the absolute maximum ratings.
- Never apply signal to the LCD module without power supply.
- Keep signal line as short as possible to reduce external noise interference.
- IC chip (e.g. TAB or COG) is sensitive to light. Strong light might cause malfunction. Light sealing structure casing is recommended.
- Make sure there is enough space (with cushion) between case and LCD panel, to prevent external force passed on to the panel; otherwise that may cause damage to the LCD and degrade its display result.
- Avoid showing a display pattern on screen for a long time (continuous ON segment).
- LCD module reliability may be reduced by temperature shock.
- When storing and operating LCD module, avoids exposure to direct sunlight, high humidity, high or low temperature. They may damage or degrade the LCD module.
- Never leave LCD module in extreme condition (max./min storage/operate temperature) for more than 48hr.
- Recommend LCD module storage conditions is 0 C~40 C <80%RH.
- LCD module should be stored in the room without acid, alkali and harmful gas.
- Avoid dropping & violent shocking during transportation, and no excessive pressure press, moisture and sunlight.
- LCD module can be easily damaged by static electricity. Please maintain an optimum anti-static working environment to protect the LCD module. (eg. ground the soldering irons properly)
- Be sure to ground the body when handling LCD module.
- Only hold LCD module by its sides. Never hold LCD module by applying force on the heat seal or TAB.
- When soldering, control the temperature and duration avoid damaging the backlight guide or diffuser which might degrade the display result such as uneven display.
- Never let LCD module contact with corrosive liquids, which might cause damage to the backlight guide or the electric circuit of LCD module.
- Only clean LCD with a soft dry cloth, Isopropyl Alcohol or Ethyl Alcohol. Other solvents (e.g. water) may damage the LCD.
- Never add force to components of LCD module. It may cause invisible damage or degrade the module's reliability.
- When mounting LCD module, please make sure it is free from twisting, warping and bending.
- Do not add excessive force on surface of LCD, which may cause the display color change abnormally.
- LCD panel is made with glass. Any mechanical shock (e.g. dropping from high place) will damage the LCD module.

9. 液晶显示模块设计和使用须知

- 请注意 V0, VCOM 的设定, 以确保液晶显示模块在不同的使用温度下以及在不同的视角和位置观察模块显示, 均能达到最佳对比度, 请务必将应用电路上设置为对比度可调。
- 请注意液晶显示模块的显示品质判定是指在正常对比度下以及视窗 (V. A) 范围内进行的, 非正常对比度下液晶可能会出现非预期的显示不良, 应注意区分。
- 请勿在最大额定值以外使用液晶显示模块。
- 请勿在没有接通电源的条件下, 给液晶显示模块输送信号。
- 请尽可能缩短信号线的连接, 以避免对液晶显示模块的信号干扰。
- 集成电路因 IC 芯片 (如 TAB 或 COG) 对紫外线极为敏感, 强光环境下可能会引起液晶显示模块功能失效, 故应采用不透光的外壳。
- 请在液晶显示模块与外壳之间保留足够的空间 (可使用衬垫), 以缓冲外力对液晶显示模块的损坏或因受力不均而产生的显示不匀等异常现象。
- 避免液晶显示屏在某一画面下长时间点亮, 否则有出现残影的风险; 请通过软件每隔一段时间改变一次画面。
- 液晶显示模块的可靠性可能因温度冲击而降低。
- 请勿在阳光直射、高湿、高温或低温下储存和使用液晶显示模块, 这将造成液晶显示模块的损坏或失效。
- 请勿在极限环境 (最大/最小存储/工作温度) 下使用或放置液晶显示模块超过 48 小时以上。
- 液晶显示模块建议存储条件为: 0 C~40 C <80%RH。
- 请勿让液晶显示模块存储于带有酸性, 碱性, 有害气体环境之中。
- 在运输过程中, 请勿让液晶显示模块跌落与猛烈震动, 同时避免异常挤压, 高湿度, 与阳光照射。
- 液晶显示模块极易受静电损坏, 请务必保证液晶显示模块在防静电的工作环境中使用或保存。(如: 烙铁正确接地, 等)
- 拿取液晶显示模块时需注意操作人员的接地情况。
- 请手持液晶显示模块的边沿取放模块, 防止热压纸或 TAB 部位受力。
- 焊接液晶模块时, 请注意控制烙铁的温度、焊接时间, 以免烫坏导光板或偏光片, 导致显示不匀等不良现象发生。
- 请勿使用洗板水等腐蚀性液体接触液晶模块, 以免腐蚀导光板或模块电路。
- 仅可使用柔软的干布, 异丙醇或乙醇清洁

- Protective film is attached on LCD screen. Be careful when peeling off this protective film, since static electricity may be generated.
- Polarizer on LCD gets scratched easily. If possible, do not remove LCD protective film until the last step of installation.
- When peeling off protective film from LCD, static charge may cause abnormal display pattern. The symptom is normal, and it will turn back to normal in a short while.
- LCD panel has sharp edges, please handle with care.
- Never attempt to disassemble or rework LCD module.
- If display panel is damaged and liquid crystal substance leaks out, be sure not to get any in your mouth, if the substance comes into contact with your skin or clothes promptly wash it off using soap and water.

10. CTP Mounting Instructions

10.1 Bezel Mounting (Figure 1)

- The bezel window should be bigger than the CTP active area. It should be $\geq 0.5\text{mm}$ each side.
- Gasket should be installed between the bezel and the CTP surface.
The final gap should be about 0.5~1.0mm.
- It is recommended to provide an additional support bracket for backside support when necessary (e.g. slim type TFT module without mounding structure). They should only provide appropriate support and keep the module in place.
- The mounting structure should be strong enough to prevent external uneven force or twist act onto the module.

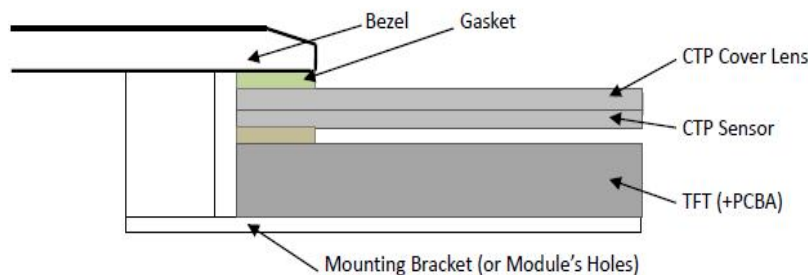

Figure 1

1

10.2 Surface Mounting (Figure 2)

- As the CTP assembling on the countersink area with double side adhesive.
The countersink area should be flat and clean to ensure the double side adhesive installation result.
- The Bezel is recommend to keep a gap ($\geq 0.3\text{mm}$ each side) around the cover lens for tolerance.
- It is recommended to provide an additional support bracket with

液晶屏表面，其他任何溶剂(如:水)都有可能损坏液晶模块。

- 请勿挤压液晶显示模块上的元器件，以避免产生潜在的损坏或失效而影响产品可靠性。
- 装配液晶显示模块时，请务必注意避免液晶显示模块的扭曲或变形。
- 请勿挤压液晶显示屏表面，这将导致显示颜色的异常。
- 液晶屏由玻璃制作而成，任何机械碰撞(如从高处跌落)均有可能损坏液晶显示模块。
- 液晶屏表面带有保护膜，揭除保护膜时需要注意可能产生的静电。
- 因液晶显示屏表面的偏光片极易划伤，安装完成之前请尽量不要揭下保护膜。
- 请缓慢揭除保护膜，在此过程中液晶显示屏上可能会产生静电，此为正常情况，可在短时间内消失。
- 请注意避免被液晶显示屏的边缘割伤。
- 请不要试图拆卸或改造液晶显示模块。
- 当液晶显示屏出现破裂，内部液晶液体可能流出；相关液体不可吞吃，绝对不可接触嘴巴，如接触到皮肤或衣服，请使用肥皂与清水彻底清洗。

10. 电容触摸屏安装指导

10.1 面框安装 (附图 1)

- 客户面框窗口应大于 CTP 动作区域，各边离动作区应 $\geq 0.5\text{mm}$ 。
- 面框与 CTP 面板间应垫有胶垫，其最终间隙约为 0.5~1.0mm。
- 建议必要时在背面提供附加支架(例如无安装结构的薄型 TFT 模块)，应仅利用适当支撑以保持模块位置。
- 安装结构应具有足够的强度，以防止外部不均匀力或扭曲力作用到模块上。

10.2 嵌入安装 (附图 2)

- 客户面框应具有使用双面胶粘贴 CTP 的结构沉台面，其粘贴面要求平整且洁净无污染以保证粘帖牢靠。
- 考虑到制作误差，建议面框与 CTP 盖板之间四周留有 $\geq 0.3\text{mm}$ 间隙。

- gasket for backside support when necessary (e.g. TFT module without mounding structure). They should only provide appropriate support and keep the module in place.
- The mounting structure should be strong enough to prevent external uneven force or twist act onto the module

- 建议必要时在背面提供垫有胶垫附加支架 (例如无安装结构的 TFT 模块), 应仅利用适当支撑以保持模块位置。
- 安装结构应具有足够的强度, 以防止外部不均匀力或扭曲力作用到模块上。

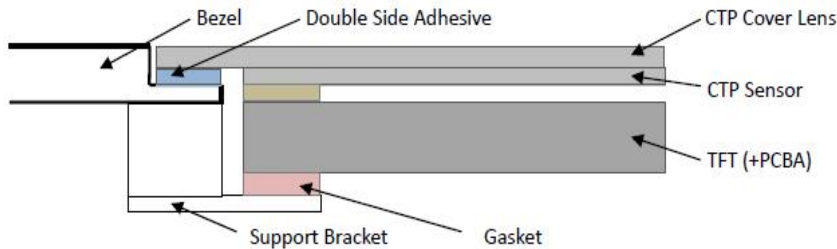

Figure 2

10.3 Additional Cover Lens Mounting (Figure 3)

- For the case of additional cover Lens mounting, it is necessary to recheck with the CTP specification about the material and thickness to ensure the functionality.
- It should keep a 0.2~0.3mm gap between the cover lens and the CTP surface..
- The cover lens window should be bigger than the active area of the CTP.It should be $\geq 0.5\text{mm}$ each side.
- It is recommended to provide an additional support bracket for backside support when necessary (e.g. slim type TFT module without mounding structure). They should only provide appropriate support and keep the module in place.
- The mounting structure should be strong enough to prevent external uneven force or twist act onto the module.

10.3 覆加盖板 (附图 3)

- 需要覆加玻璃盖板的安装, 为确保其功能, 有必要查看产品规格书中有关盖板材料和厚度的说明。
- 玻璃盖板与 CTP 表面之间应留有 0.2~0.3mm 间隙。
- 玻璃盖板视窗应大于 CTP 动作区域, 各边离动作区应 $\geq 0.5\text{mm}$ 。
- 建议必要时在背面提供附加支架 (例如无安装结构的薄型 TFT 模块), 应仅利用适当支撑以保持模块位置。
- 安装结构应具有足够的强度, 以防止外部不均匀力或扭曲力作用到模块上。

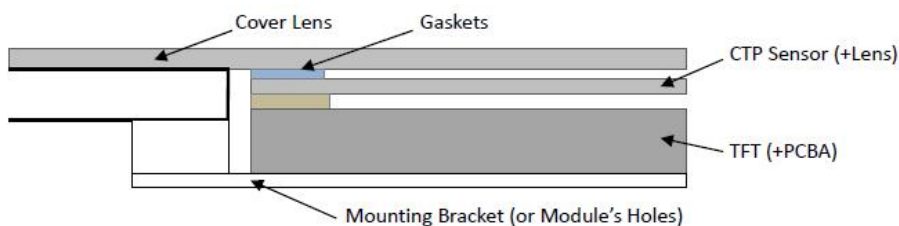

Figure 3

3

11. RTP Mounting Instructions

- It should bezel touching the RTP Active Area (A.A.) to prevent abnormal touch.It should left gab D=0.2~0.3mm in between. (Figure 4)
- Outer bezel design should take care about the area outside the A.A. Those areas contain circuit wires which is having different thickness. Touching those areas could de-form the ITO film. As a result bezel the ITO film be damaged and shorten its lifetime. It is suggested to protect those areas with gasket (between the bezel and RTP).The suggested figures are B $\geq 0.50\text{mm}$; C $\geq 0.50\text{mm}$. (Figure 4)

11. 电阻触摸屏安装指导

- 为避免面框直接压在动作区 (A. A.) 上造成误动作, 面框与电阻触摸屏 (RTP) 之间应留有一定的空隙 D=0.2~0.3mm 之间. (附图 4)
- 设计面框时, 要注意用面框保护触摸屏四周的非保证操作区域, 因为布线区域在此处形成一台阶, 在此区域附近操作时 ITO Film 变形较大, 容易导致 ITO 损坏而降低寿命。为保护 RTP 和避免误操作, 在 RTP 与面框之间垫缓冲物 (Gasket), 我们建议设计面框应覆盖动作区的边缘, 面框边

- The bezel side wall should keep space $E = 0.2 \sim 0.3\text{mm}$ from the RTP. (Figure 4)

- 缘到 V. A. 区的距离 $B \geq 0.50\text{mm}$; 垫圈内边缘到 V. A. 区的距离 $C \geq 0.50\text{mm}$. (附图 4)
在设计面框与 RTP 组装时, 应考虑到面框内侧与 RTP 外侧的间距 $E \geq 0.2\text{mm}$. (附图 4)

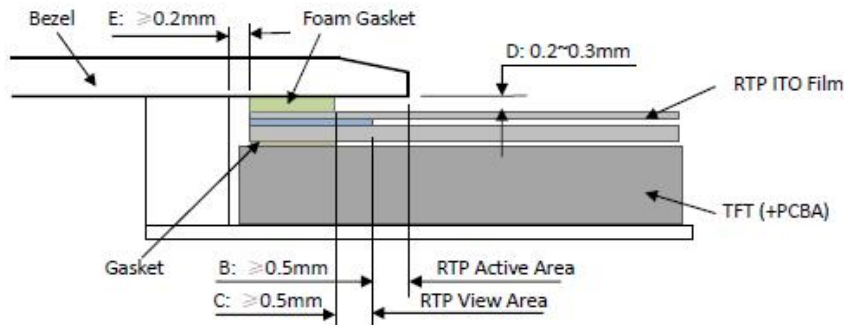

Figure 4

- In general design, RTP V.A. should be bigger than the TFT V.A. and RTP A.A. should be bigger than the TFT A.A. (Figure 5)

- 通常设计时:
RTP 的可视区 V.A. 应不小于 TFT 的可视区 V.A.
及 RTP 的动作区 A.A. 应不小于 TFT 的动作区 A.A.
(附图 5)

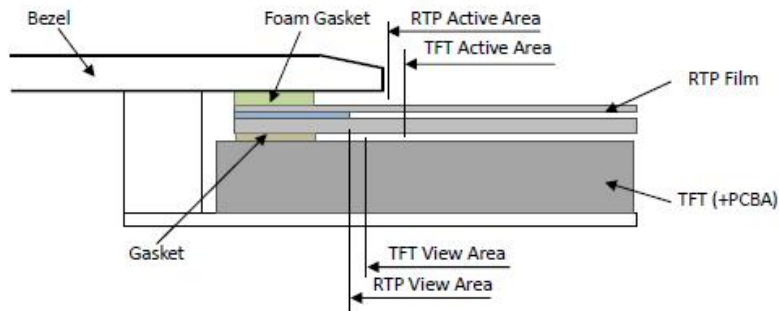
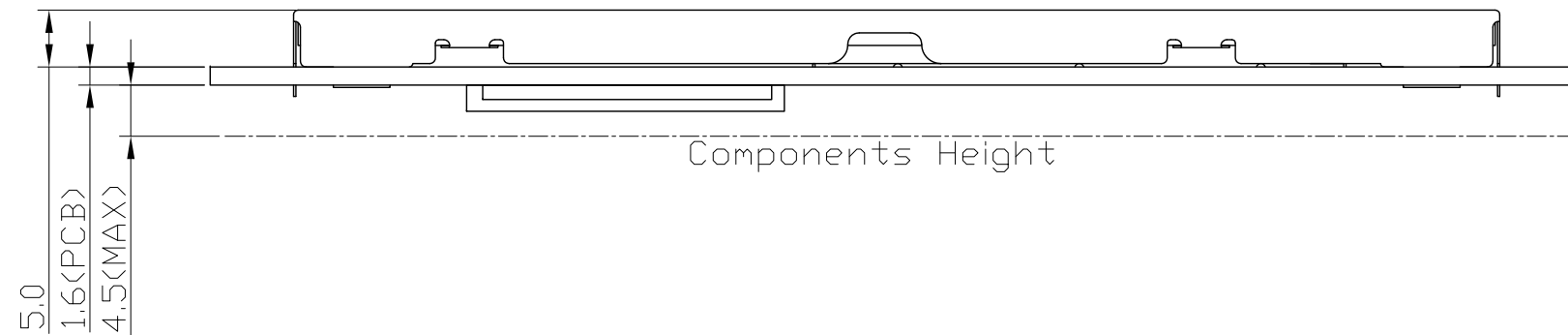
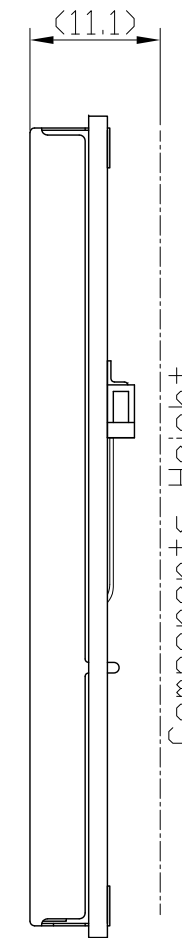
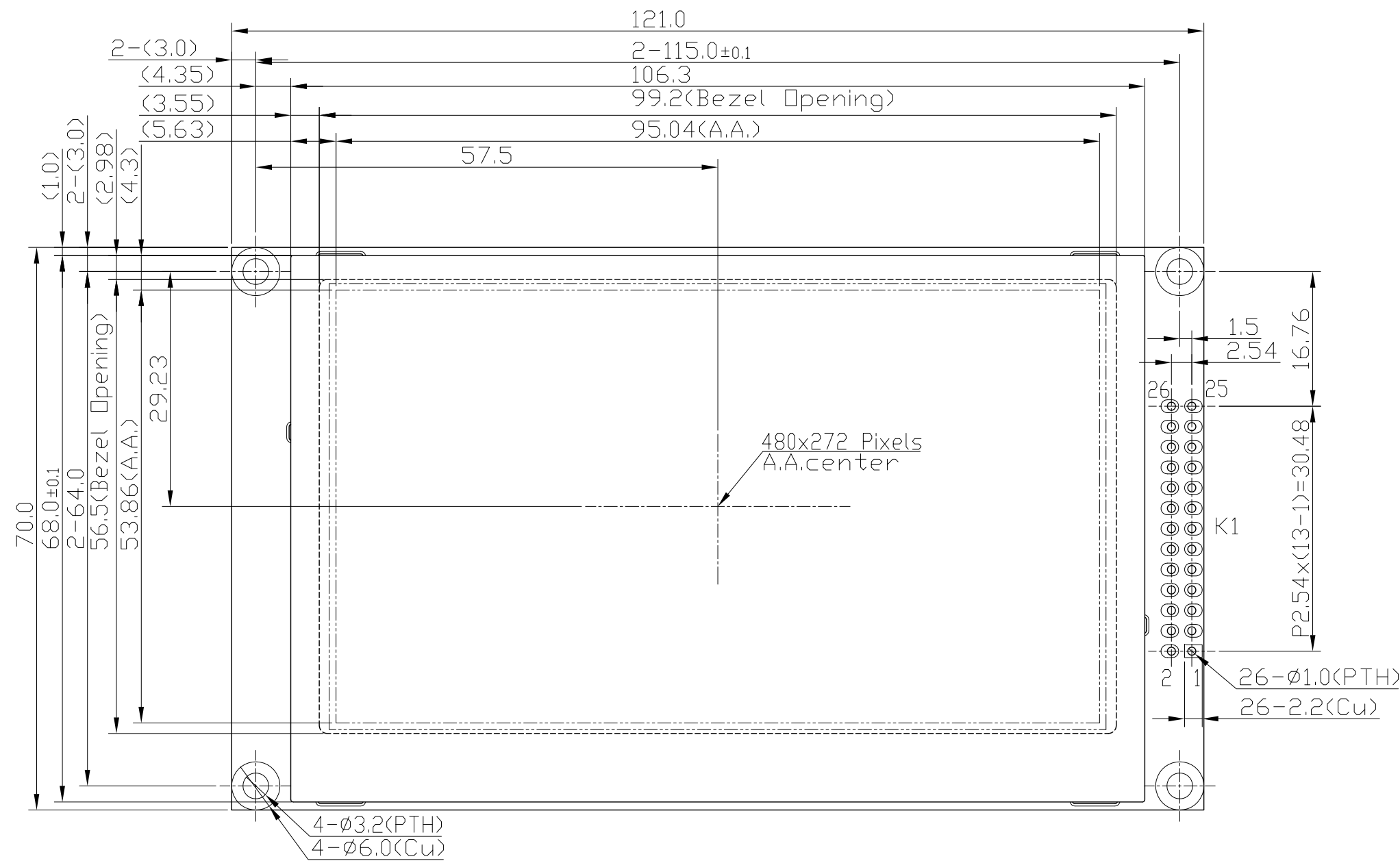

Figure 5

Warranty

This product has been manufactured to our company's specifications as a part for use in your company's general electronic products. It is guaranteed to perform according to delivery specifications. For any other use apart from general electronic equipment, we cannot take responsibility if the product is used in medical devices, nuclear power control equipment, aerospace equipment, fire and security systems, or any other applications in which there is a direct risk to human life and where extremely high levels of reliability are required. If the product is to be used in any of the above applications, we will need to enter into a separate product liability agreement.

- We cannot accept responsibility for any defect, which may arise from additional manufacturing of the product (including disassembly and reassembly), after product delivery.
- We cannot accept responsibility for any defect, which may arise after the application of strong external force to the product.
- We cannot accept responsibility for any defect, which may arise due to the application of static electricity after the product has passed our company's acceptance inspection procedures.
- When the product is in CCFL models, CCFL service life and brightness will vary according to the performance of the inverter used, leaks, etc. We cannot accept responsibility for product performance, reliability, or defect, which may arise.
- We cannot accept responsibility for intellectual property of a third part, which may arise through the application of our product to our assembly with exception to those issues relating directly to the structure or method of manufacturing of our product.



No	Pin Name
1	VSS
2	VSS
3	VDD
4	VDD
5	A0
6	/CS
7	/RES
8	D0(SI)
9	D1(SO)
10	D2
11	D3
12	D4
13	D5
14	D6
15	D7
16	TE
17	/RD
18	/WR(SCK)
19	BL_ADJ
20	SPI_EN
21	NC
22	NC
23	NC
24	NC
25	NC
26	NC

- Note:
- *1. LCD Display Type : TFT, Transmissive
 - *2. Operating Voltage : 3.3V
 - *3. Backlight Color : White LED
 - *4. Pixel Arrangement : RGB-STRIPE
 - *5. Color Depth : 16.7M Colors
 - *6. Interface: MCU_8bit/SPI_3wire
 - *7. Operating Temperature : -20°C~70°C
 - *8. Storage Temperature : -30°C~80°C
 - *9. Unmarked Tolerance: ≤150,±0.3; >150,±0.5

C				
B				
A				
Rev	Note			Date
Dwg	Title	LMT043DNFFWD-NCN Outline Dwg		
Dwg No.	MK-006655-1-1	Date	2019-06-11	
Scale	3/2	Tol.	±0.5	Unit mm
Approved		Checked		Paper Size A3
			Drawn	HeHongLiang
TOPWAY				