



深圳市拓普微科技开发有限公司

SHENZHEN TOPWAY TECHNOLOGY CO., LTD.

LMT050DNCFWU-1

LCD Module User Manual

Prepared by: Liusanyong Date: 2019-01-27	Checked by: Date:	Approved by: Date:
---	----------------------------------	-----------------------------------

Rev.	Descriptions	Release Date
0.1	Preliminary	2019-01-27

Table of Content

1. General Specification	3
2. Block Diagram.....	3
3. Terminal Functions.....	4
3.1 Interface	4
4. Absolute Maximum Ratings	5
5. Electrical Characteristics	5
5.1 DC Characteristics (MCU terminal).....	5
5.2 LED Backlight Circuit Characteristics	5
5.3 Power ON/OFF Sequence.....	6
6. AC Characteristics.....	7
6.1 AC Timing	7
6.2 Data Input format.....	8
7. Optical Characteristics.....	9
8. Precautions of using LCD Modules.....	11

1. General Specification

Screen Size(Diagonal) :	5.0 inch
Resolution :	800(RGB) x 480
Signal Interface :	24bit parallel interface
Color Depth :	16.7M color (24bit)
Pixel Pitch :	0.36 x 0.36 (mm)
Pixel Configuration :	RGB Stripe
Display Mode :	Transmissive / normal white
Surface Treatment :	Anti-Glare Treatment
Viewing Direction :	6H (*1) (gray scale inverse) 12H (*2)
Outline Dimension :	120.7 x 75.8 x 3.1 (mm) (exclude FPC, see attached drawing for details)
Active Area :	108 x 64.8 (mm)
Backlight :	2x7 LEDs
Operating Temperature :	-20 ~ +70°C
Storage Temperature :	-30 ~ +80°C

Note:

*1. For saturated color display content (eg. pure-red, pure-green, pure-blue, or pure-colors-combinations).

*2. For “color scales” display content.

*3. Color tone may slightly change by Temperature and Driving Condition.

2. Block Diagram

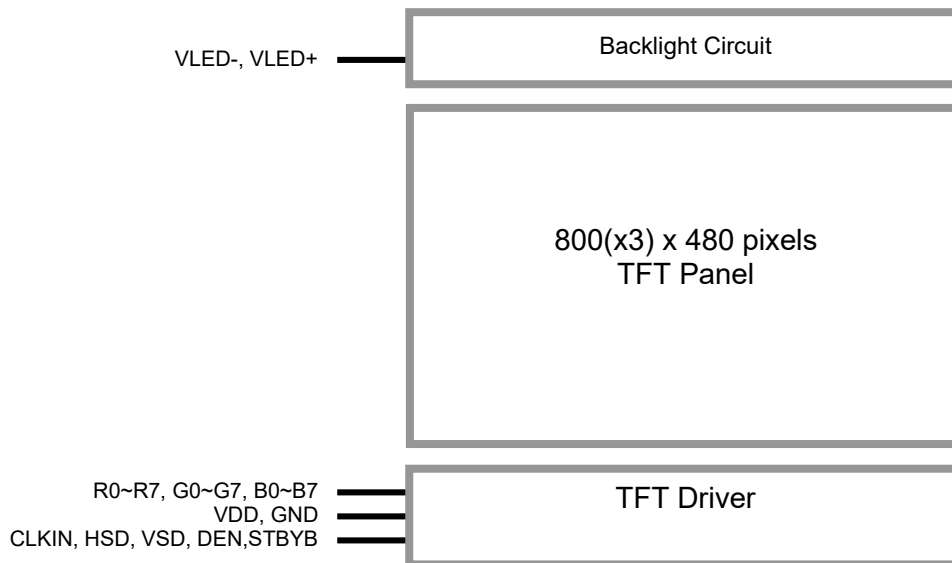

3. Terminal Functions

3.1 Interface

Pin No.	Pin Name	I/O	Descriptions
1	VLED-	P	Backlight LED Cathode supply
2	VLED+	P	Backlight LED Anode supply
3	GND	P	Power Ground (0V)
4	VDD	P	Positive Power Supply
5	R0	I	Red color data input
:	:		
12	R7		
13	G0	I	Green color data input
:	:		
20	G7		
21	B0	I	Blue color data input
:	:		
28	B7		
29	GND	P	Power Ground (0V)
30	CLKIN	I	Clock for input data. Data latched at falling edge of this signal.
31	STBYB	I	Standby mode. STBYB="1": Normally operation. STBYB="0": Standby mode .Timing controller, source driver will turn off, all output are High-Z.
32	HSD	I	Horizontal Sync signal input
33	VSD	I	Vertical Sync Signal Input
34	DEN	I	Data input enable. Effective only in DE mode.
35	NC	-	No connection, leave open
36	GND	P	Power Ground (0V)
37	NC	-	No connection, leave open
38	NC		
39	NC		
40	NC		

Note:

Interface: HS, VS mode (default)

4. Absolute Maximum Ratings

Items	Symbol	Min.	Max.	Unit	Condition
Supply Voltage	V _{DD}	-0.3	+4.0	V	GND = 0V
Operating Temperature	T _{OP}	-20	+70	°C	No Condensation
Storage Temperature	T _{ST}	-30	+80	°C	No Condensation

Cautions:

Any Stresses exceeding the Absolute Maximum Ratings may cause substantial damage to the device. Functional operation of this device at other conditions beyond those listed in the specification is not implied and prolonged exposure to extreme conditions may affect device reliability.

5. Electrical Characteristics

5.1 DC Characteristics (MCU terminal)

GND=0V, V_{DD} =3.3V, T_{OP} =25°C

Items	Symbol	MIN.	TYP.	MAX.	Unit	Applicable Pin
Operating Voltage	VDD	3.0	3.3	3.6	V	VDD
Input High Voltage	V _{IH}	0.7VDD	-	VDD	V	Input pins
Input Low Voltage	V _{IL}	GND	-	0.3VDD	V	Input pins
Output Signal Low Voltage	V _{oH}	-	-	GND+0.4	V	
Output Signal High Voltage	V _{IL}	VDD-0.4	-	-	V	
Operating Current (*1)	I _{DD}	-	90	-	mA	All black

Note.

*1. For different LCM, the value may have a bit of difference.

*2. To test the current dissipation, use "all Black Pattern".

5.2 LED Backlight Circuit Characteristics

I_{fVLED+}=40mA, T_{OP}=25°C

Items	Symbol	MIN.	TYP.	MAX.	Unit	Note
Forward Voltage	V _f	17.5	21.7	24.7	V	
Forward Current	I _{fVLED+}	-	40	50	mA	
Life Time	-	10,000	(20,000)	-	hr	

Cautions:

Exceeding the recommended driving current could cause substantial damage to the backlight and shorten its lifetime.

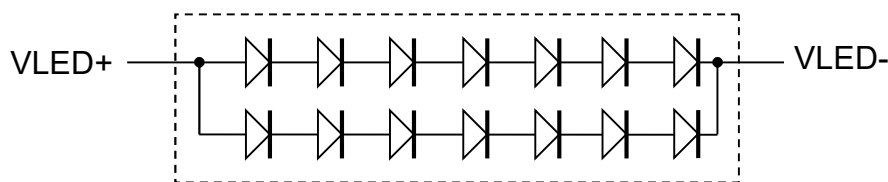

No. of LEDs = 2x7 pcs

5.3 Power ON/OFF Sequence

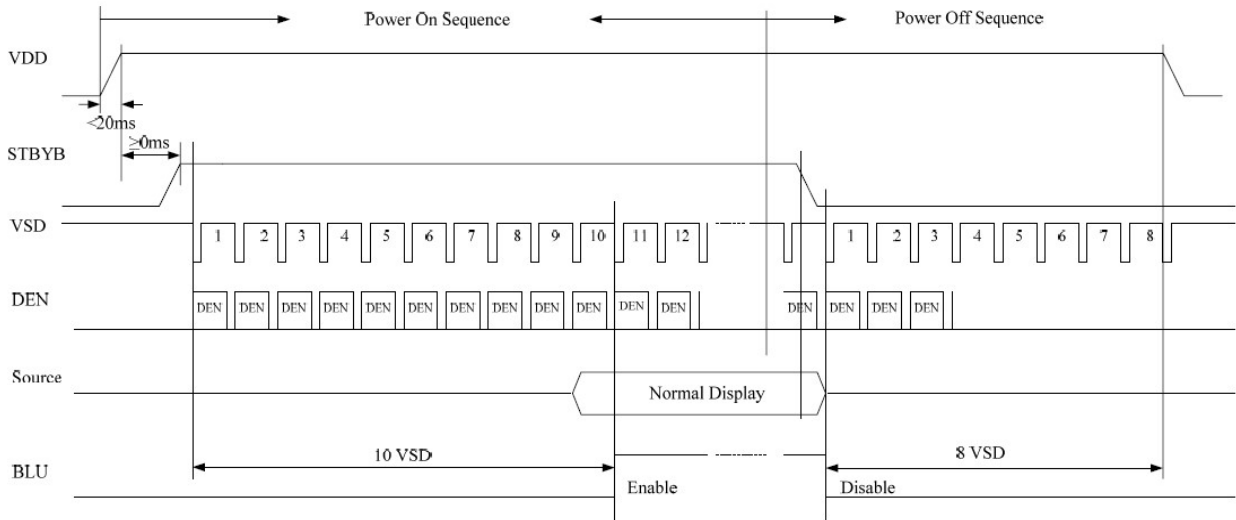

Power On/Off Sequence

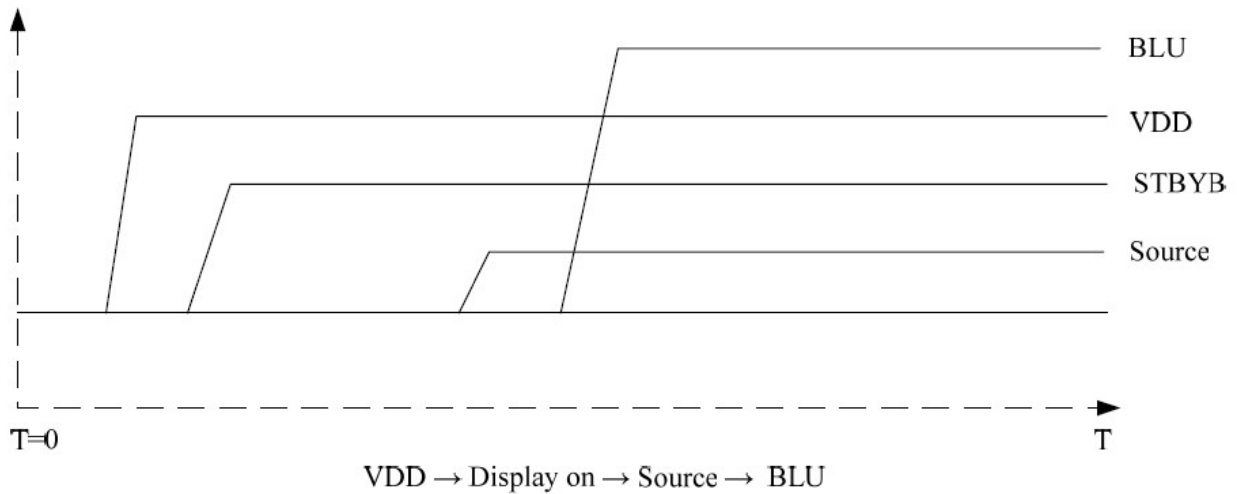

Power On Sequence

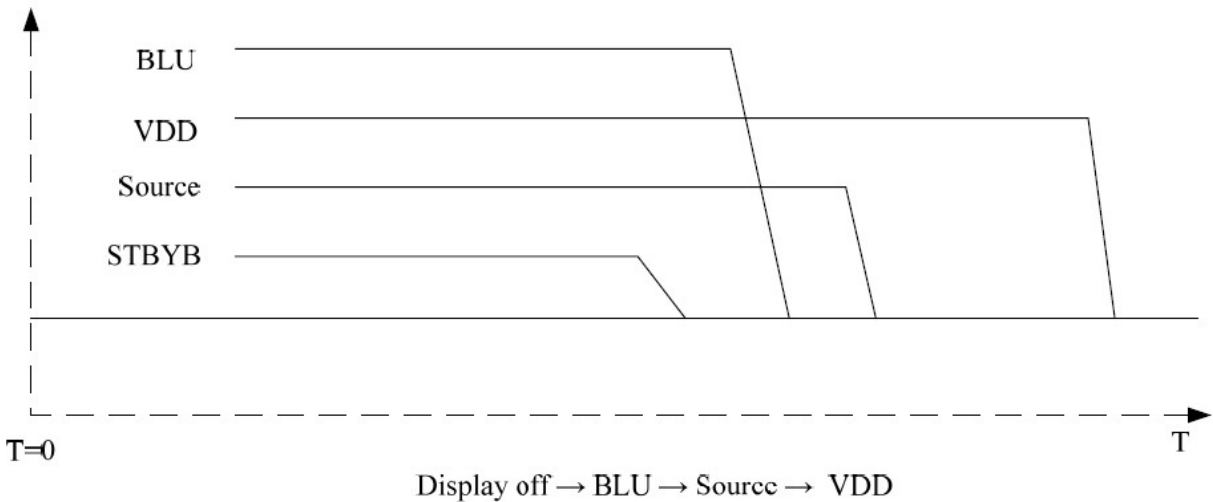

Power OFF Sequence

6. AC Characteristics

6.1 AC Timing

GND=0V, V_{DD}=3.3V, T_{OP}=25°C

Item	Symbol	MIN.	TYP.	MAX.	Unit	Remark
HS setup time	Thst	8	-	-	ns	
HS hold time	Thhd	8	-	-	ns	
VS setup time	Tvst	8	-	-	ns	
VS hold time	Tvhd	8	-	-	ns	
Data setup time	Tdsu	8	-	-	ns	
Data hole time	Tdhd	8	-	-	ns	
DE setup time	Tesu	8	-	-	ns	
DVDD Power On Slew rate	Tpor	-	-	20	ms	
CLKIN cycle time	Tcph	20	-	-	ns	
CLKIN pulse duty	Tcwh	40	50	60	%	

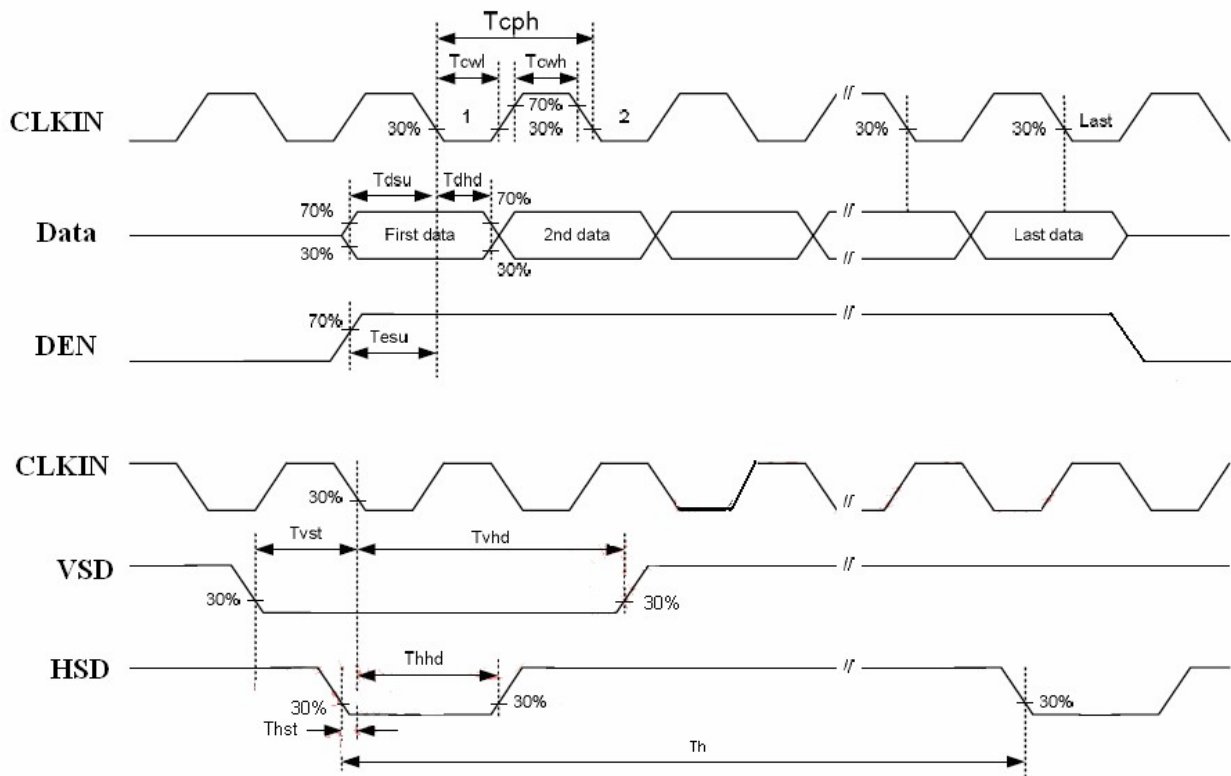

Input Clock and Data Timing Diagram

6.2 Data Input format

Item	Symbol	MIN.	TYP.	MAX.	Unit	Remark
Horizontal Display Area	thd	800			DCLK	
CLKIN Frequency	fclk	-	30	50	MHz	
One Horizontal Line	th	889	928	1143	CLKIN	
HSD pulse width	thpw	1	48	255	CLKIN	
HSD Blanking	thb	88			CLKIN	
HSD Front Porch	thfp	1	40	255	CLKIN	
Vertical Display Area	tvd	480			TH	
VSD period time	tv	513	525	767	TH	
VSD pulse width	tvpw	3	3	255	TH	
VSD Blanking	tvb	32			TH	
VSD Front Porch	tvfp	1	13	255	TH	

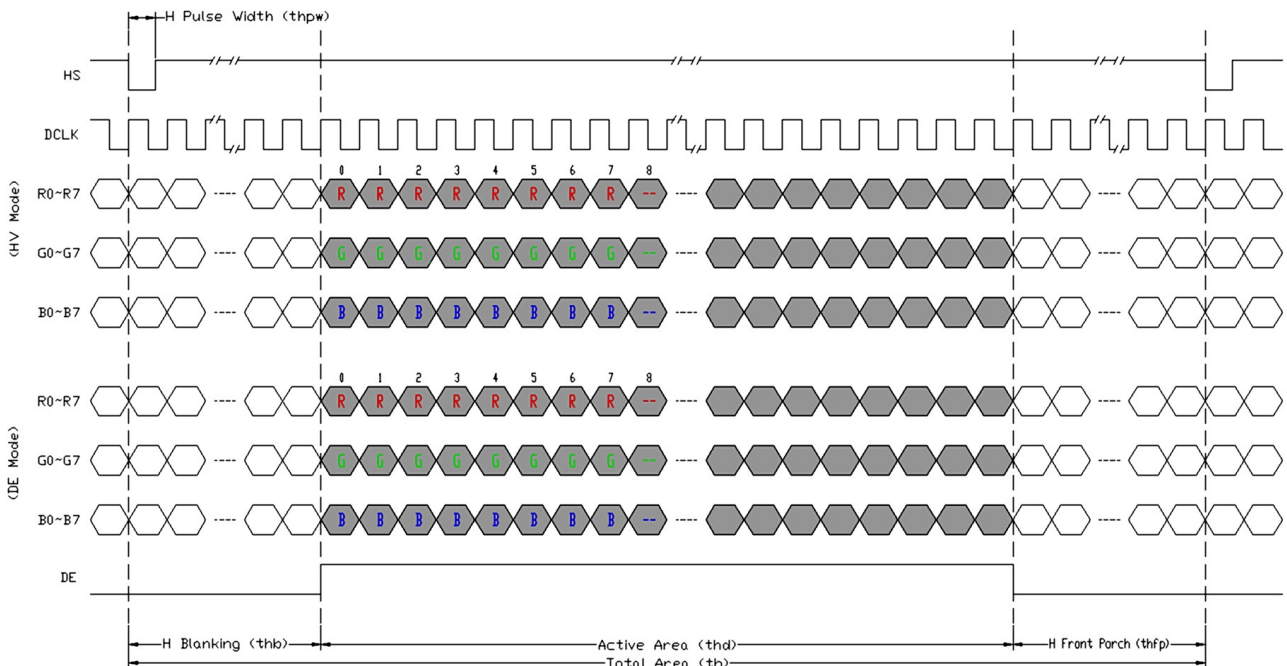

Horizontal input timing diagram

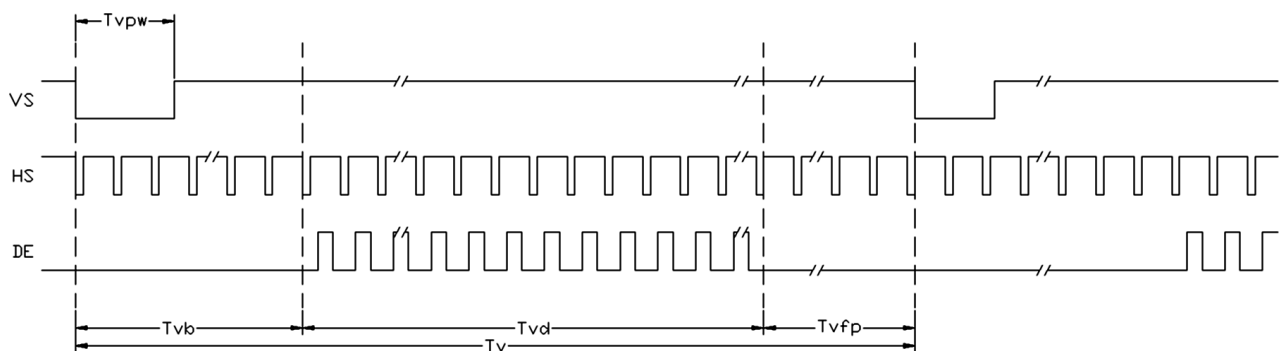

Vertical input timing diagram

7. Optical Characteristics

Item	Symbol	Condition	MIN.	TYP.	MAX.	UNIT	Note.
Viewing angle	θ_T	(CR \geq 10)	40	50	-	degree	Note 2
	θ_B		60	70	-		
	θ_L		60	70	-		
	θ_R		60	70	-		
Contrast ratio	CR	$\theta=0^\circ$	500	600	-	-	Note 1,3
Response Time	T_{on}	25°C	-	20	30	msec	Note 1,4
	T_{off}					msec	
Chromaticity	White	Backlight is on	X	0.260	0.310	0.360	Note 1,5
			Y	0.280	0.330	0.380	
	Red		X	0.540	0.590	0.640	
			Y	0.300	0.350	0.400	
	Green		X	0.298	0.348	0.398	
			Y	0.520	0.570	0.620	
	Blue		X	0.095	0.145	0.195	
			Y	0.060	0.110	0.160	
Luminance	L		200	250	-	cd/m ²	Note 1,6
NTSC			-	50		%	Note 5
Luminance uniformity	U		75	80	-	%	Note 1,7

Test Conditions:

1. IF= 40mA, VF=21.7V, and the ambient temperature is 25. °C
2. The test systems refer to Note 1 and Note 2.

Note 1:

The data are measured after LEDs are turned on for 5 minutes. LCM displays full white. The brightness is the average value of 9 measured spots. Measurement equipment SR-3A (1°)

Measuring condition:

- Measuring surroundings: Dark room
- Measuring temperature: Ta=25°C.
- Adjust operating voltage to get optimum contrast at the center of the display.

Note 2:

The definition of viewing angle:

Refer to the graph below marked by θ and ϕ

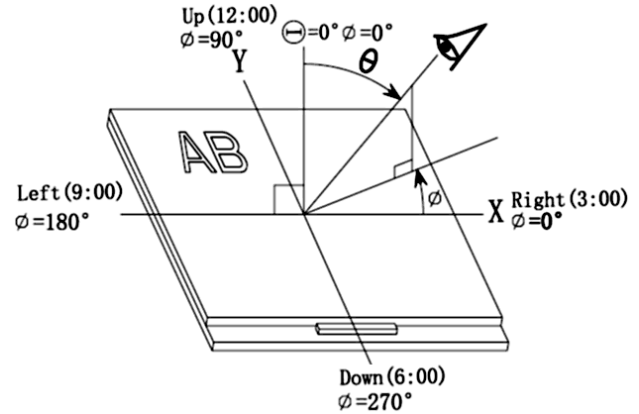

Note 3:

The definition of contrast ratio (Test LCM using SR-3A (1°)):

$$\text{Contrast Ratio (CR)} = \frac{\text{Luminance When LCD is at "White" state}}{\text{Luminance When LCD is at "Black" state}}$$

(Contrast Ratio is measured in optimum common electrode voltage)

Note 4:

Definition of Response time. (Test LCD using BM-7A(2°)):

The output signals of photo detector are measured when the input signals are changed from "black" to "white"(falling time) and from "white" to "black"(rising time), respectively.

The response time is defined as the time interval between the 10% and 90% of amplitudes. Refer to figure as below.

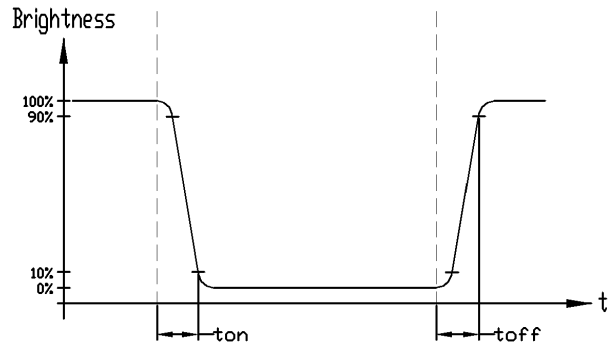

Note 5:

Definition of Color of CIE1931 Coordinate and NTSC Ratio.

Color gamut:

$$S = \frac{\text{Area of RGB triangle}}{\text{Area of NTSC triangle}} \times 100\%$$

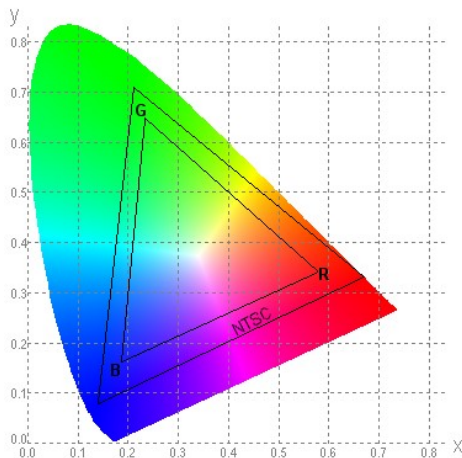

Note 6:

The luminance uniformity is calculated by using following formula.

$$\Delta Bp = Bp (\text{Min.}) / Bp (\text{Max.}) \times 100 (\%)$$

Bp (Max.) = Maximum brightness in 9 measured spots

Bp (Min.) = Minimum brightness in 9 measured spots.

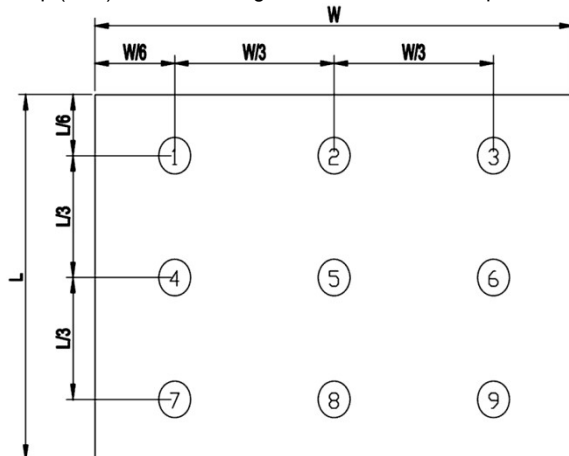

Note 7:

Measured the luminance of white state at center point

8. Precautions of using LCD Modules

Please refer to "LCD-Module-Design-Handling-Precaution.pdf".

No	Pin Name
1	VLED-
2	VLED+
3	GND
4	VDD
5	R0
:	:
12	R7
13	G0
:	:
20	G7
21	B0
:	:
28	B7
29	GND
30	CLKIN
31	STBYB
32	HSD
33	VSD
34	DEN
35	NC
36	GND
37	NC
38	NC
39	NC
40	NC

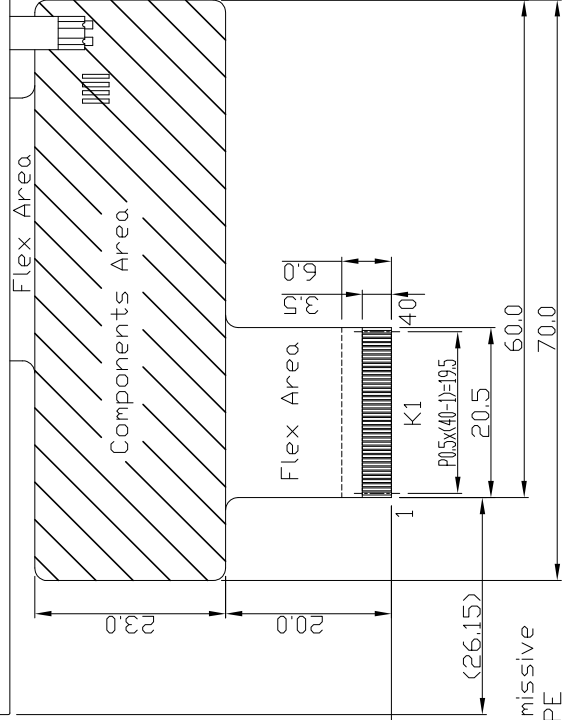
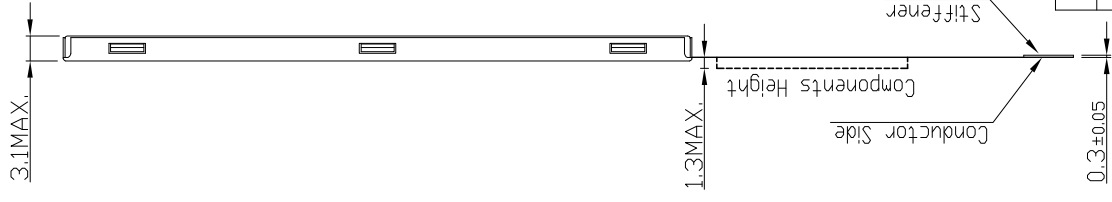
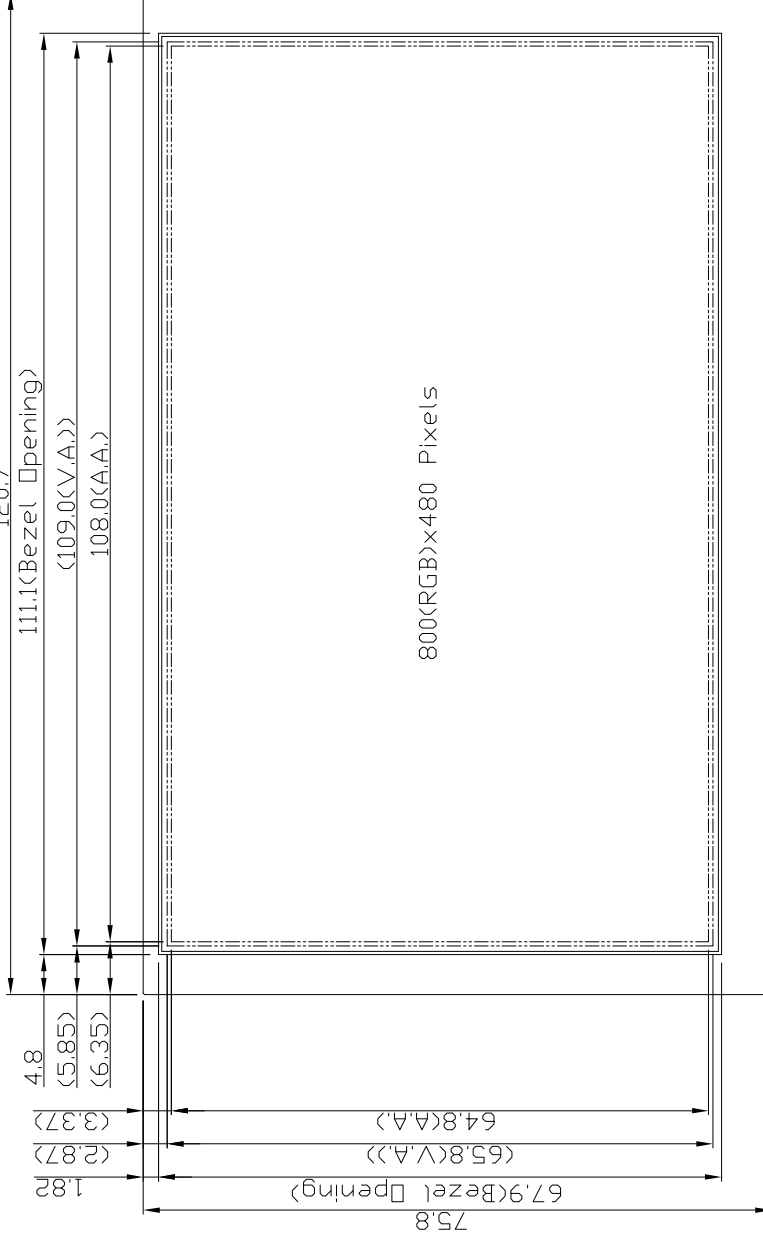

Rev					
Note					
Dwg Title	LMT050DNCFWU-1 outline Dwg				
Dwg No.	MK-006475-1-1	Unit	mm	Paper Size	A3
Scale	3/2	Tol.	±0.5	Checked	
Approved		Drawn	yangwukun		

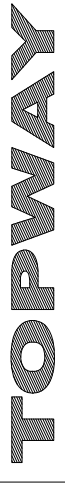

- Note:
- *1. LCD Display Type: TFT, Transmissive
 - *2. Pixel Arrangement: RGB-STRIPE
 - *3. Operating Voltage: 3.3V
 - *4. Backlight Supply: 40mA (±1.7V TYP)
 - *5. Backlight: LEDs
 - *6. Matched Connector: FH34SRJ-40S-0.5SH
 - *7. Operating Temperature: -20°C ~ 70°C
 - *8. Storage Temperature: -30°C ~ 80°C