



LMT104SDH01

LCD Module User Manual

Prepared by: Yang Date: 2012-06-19	Checked by: Date:	Approved by: Date:
---	----------------------------------	-----------------------------------

Rev.	Descriptions	Release Date
0.1	Preliminary	2009-09-16
0.2	Add Weight and Power Characteristics Refine Backlight Characteristics	2012-06-13
0.3	Add Temperature/Humidity Graph Add Major Part List & Package	2012-06-19

Table of Content

1. General Specification	3
2. Block Diagram.....	3
3. Input/Output Terminals.....	4
3.1 TFT LCD Panel	4
3.2 BackLight Connector.....	4
4. Absolute Maximum Ratings	5
5. Electrical Characteristics	5
5.1 Driving TFT LCD Panel	5
5.2 LED Backlight Circuit Characteristics.....	6
5.3 Power On/Off Sequence	7
6. AC Characteristics.....	7
6.1 Timing Conditions	7
7. Optical Characteristics	8
8. Parts.....	12
8.1 Major Part List.....	12
9. Packing.....	12
9.1 Inside of Packing.....	12
9.2 Outside of Packing-Box	12
10. Environmental / Reliability Test.....	13

1. General Specification

Signal Interface :	LVDS 6 bits
Display Technology :	a-Si TFT active matrix
Display Mode :	TN Type Full Color / Transmissive / Normal White
Screen Size(Diagonal) :	10.4 inch
Outline Dimension :	236.00x176.90x5.60 (mm)
	(see Outline DWG for details)
Active Area :	211.20x158.40 (mm)
Number of dots :	800x 3 (RGB) x 600
Dot Pitch :	0.264x0.264 (mm)
Pixel Configuration :	R.G.B. Vertical Stripe
Backlight :	White LED
Surface Treatment :	Anti-Glare
Weight:	(288g)
Viewing Direction :	12 o'clock
Operating Temperature :	-20 ~ +70°C
Storage Temperature :	-30 ~ +80°C

2. Block Diagram

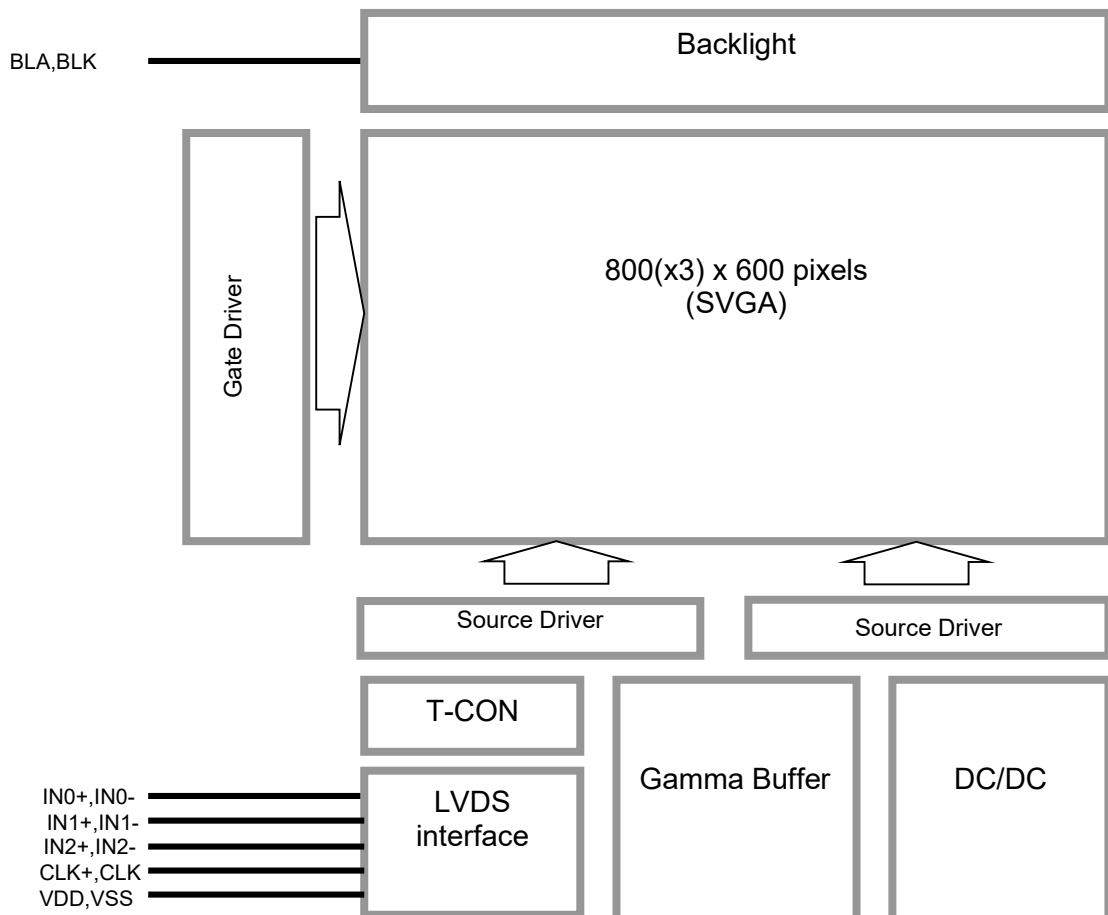

3. Input/Output Terminals

3.1 TFT LCD Panel

Pin No.	Pin Name	IO	Descriptions
1	VDD	Power	Power Supply
2			
3	GND	Power	Ground
4			
5	IN0-	Input	LVDS receiver negative signal channel 0
6	IN0+	Input	LVDS receiver positive signal channel 0
7	GND	Power	Ground
8	IN1-	Input	LVDS receiver negative signal channel 1
9	IN1+	Input	LVDS receiver positive signal channel 1
10	GND	Power	Ground
11	IN2-	Input	LVDS receiver negative signal channel 2
12	IN2+	Input	LVDS receiver positive signal channel 2
13	GND	Power	Ground
14	CLK-	Input	LVDS receiver negative signal clock
15	CLK+	Input	LVDS receiver positive signal clock
16	GND	Power	Ground
17	NC	-	No connection
18			
19	GND	Power	Ground
20			

3.2 BackLight Connector

Pin No.	Pin Name	IO	Descriptions	Wire Color
1	BLA	Power	LED driving anode (high voltage)	Red
2	BLK	Power	LED driving cathode (low voltage)	White

CN2: JST BHSR-02VS-1 (or equivalent)

Mating Connector: JST SM02B-BHSS-1-TB (or equivalent)

4. Absolute Maximum Ratings

GND=0V, T_{OP}=25°C

Items	Symbol	Min.	Max.	Unit	Condition
Power Voltage	VDD	-0.3	+5.0	V	GND = 0V
Input voltage	V _{IN}	-0.3	+5.0	V	GND= 0V
Operating Temperature	T _{OP}	-20	+70	°C	No Condensation
Storage Temperature	T _{ST}	-30	+80	°C	No Condensation

Note1: V_{IN} represent IN0±,IN1±,IN2±,CLK±

Note2: Recommended Temperature/Humidity Graph as follow

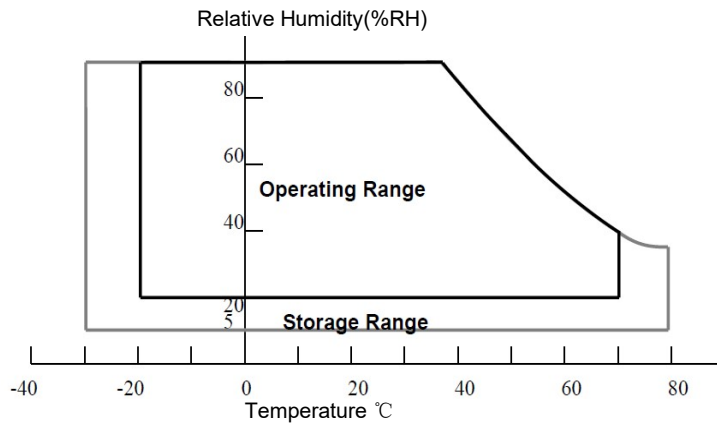

5. Electrical Characteristics

5.1 Driving TFT LCD Panel

GND=0V, V_{DD}=3.3V, T_{OP}=25°C

Items	Symbol	MIN.	TYP.	MAX.	Unit	Note
LVDS Differential input high threshold	V _{TH}	-	-	+100	mV	V _{CMLVDS} =1.2V
LVDS Differential input low threshold	V _{TL}	-100	-	-	mV	V _{CMLVDS} =1.2V
Differential input voltage	V _{ID}	0.1	-	0.6	V	
LVDS input common mode voltage	V _{CMLVDS}	V _{ID} /2	-	1.4-(V _{ID} /2)	V	
Input current	I _{IN}	-10	-	10	μA	
Supply Voltage	VDD	3.0	3.3	3.6	V	
Common Electrode Driving Signal	VCOM	-	4.36	-	V	Note1
Sync Frequency	FVD		60	70	Hz	
VDD Power Consumption	I _{DD}	-	260	380	mA	Note2
LCM Power Consumption	P _{VDD}	-	858	1368	mW	

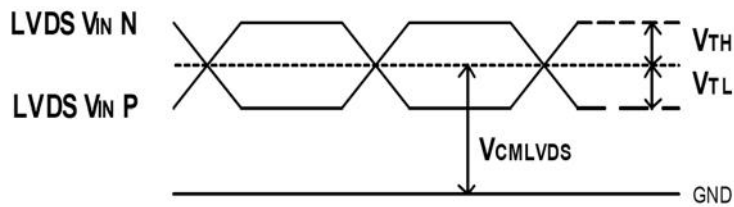

LVDS DC timing diagram

Note1: The value may be different for different LCM.

Note2: To test the current dissipation, using the “color bar” testing pattern shown as below:

- 1. White
- 2. Yellow
- 3. Cyan
- 4. Green
- 5. Magenta
- 6. Red
- 7. Blue
- 8. Black

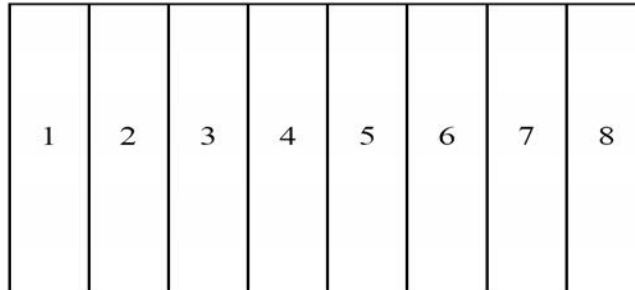

Current dissipation testin pattern

5.2 LED Backlight Circuit Characteristics

BLK=0V, T_{OP}=25°C

Parameter	Symbol	MIN.	TYP.	MAX.	Unit	Note
Forward Current	I _F	-	120.0	132	mA	
Forward Current Voltage	V _F	17.7	19.2	19.7	V	
Backlight Power Consumption	P _{BL}	-	2304	2600	mW	

Note 1: The Minimum Life of LED : 20,000 hours

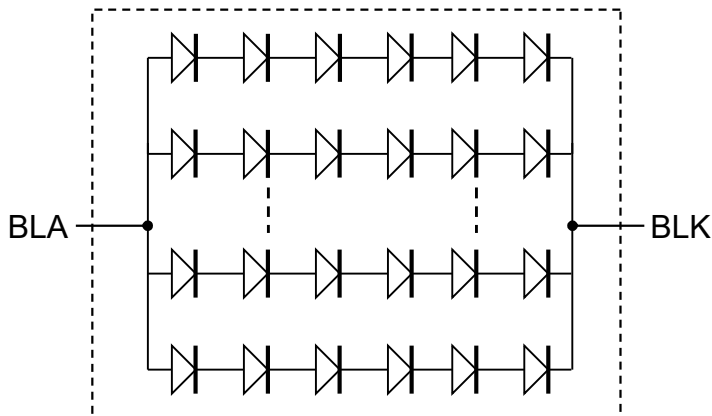

No. of LED = 6x6=36 pcs

5.3 Power On/Off Sequence

Items	Symbol	MIN.	TYP.	Max.	Unit	Note
VDD 3.0V to signal starting	Tp1	0	-	50	ms	
Signal starting to backlight on	Tp2	150	-	-	ms	
Signal off to VDD 3.0V	Tp3	0	-	50	ms	
Backlight off to signal off	Tp4	150	-	-	ms	

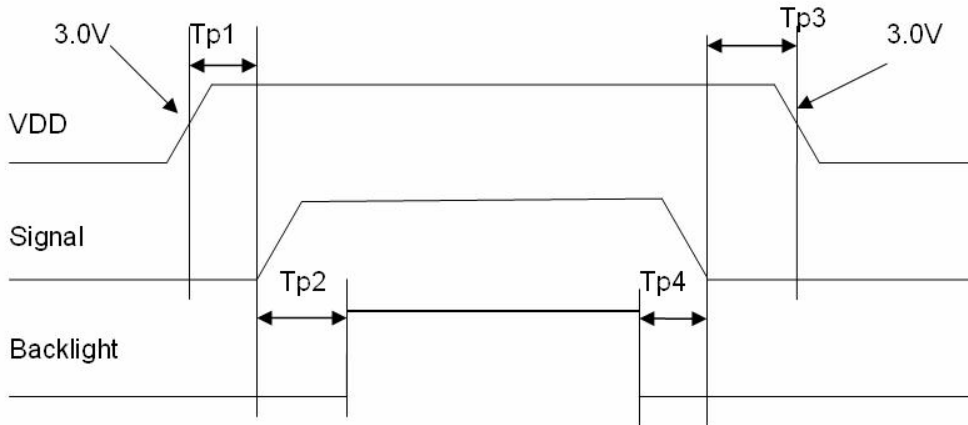

Interface Power On/Off Sequence

6. AC Characteristics

6.1 Timing Conditions

Item	Symbol	MIN.	TYP.	MAX.	Unit	Condition
Clock period	tLVCP	20.0	25	31.25	ns	
Clock high time	tLVCH	-	14.29	-	ns	
Clock low time	tLVCL	-	10.71	-	ns	
PLL wake-up time	tLVPLL	-	-	1	ms	
Input skew margin	tLVSKM	400	-	-	ps	f=85MHz

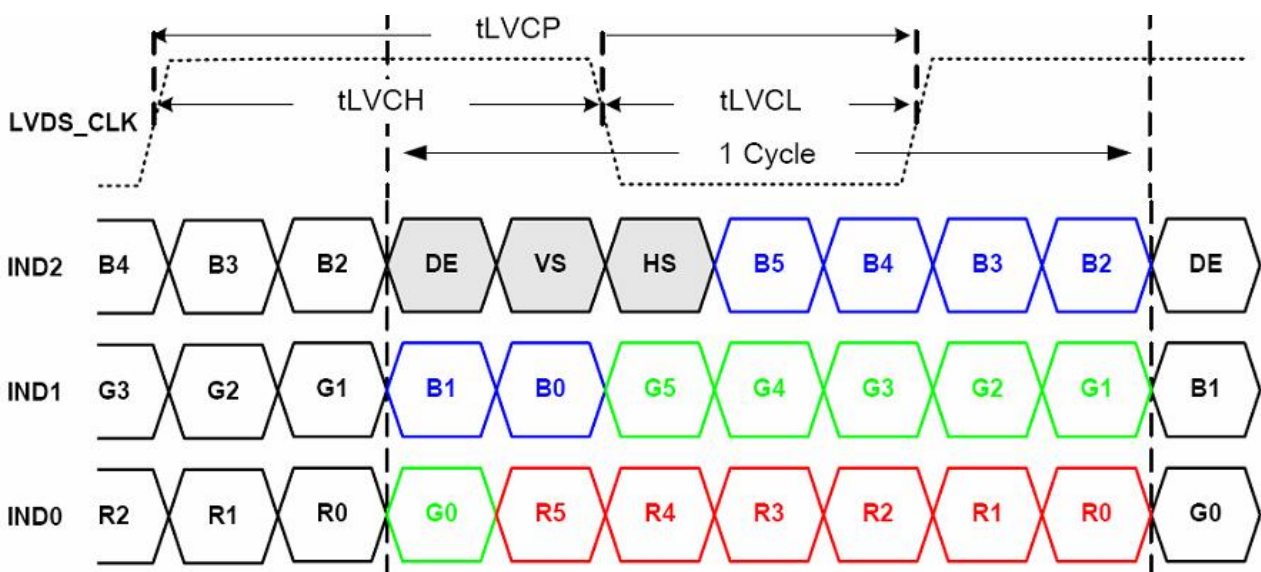

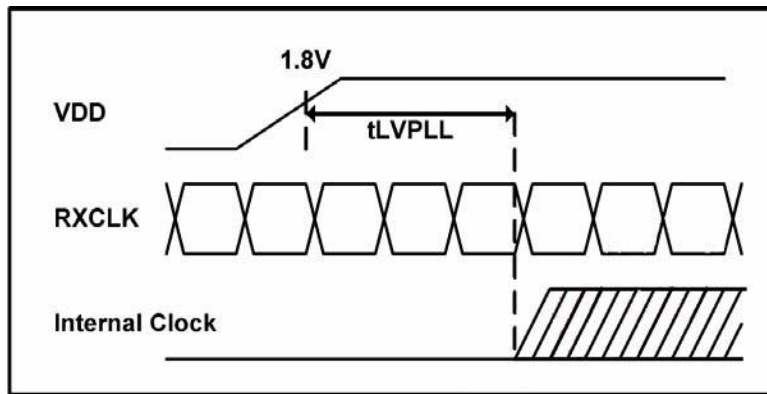

timing parameter

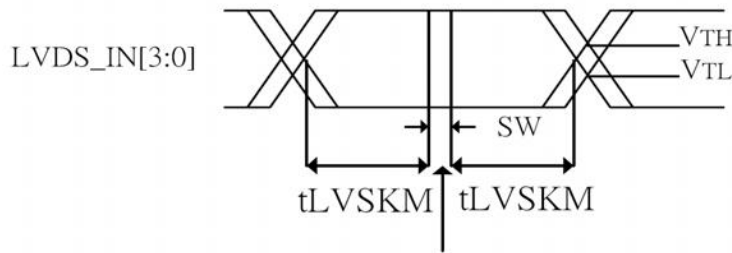

Ideal Strobe Position

SW: Setup and Hold time **Input signal data timing**

7. Optical Characteristics

Ta=25°C

Item	Symbol	Condition	Min	TYP.	MAX.	UNIT	Note.	
View Angles	θT	CR 10	35	45	-	Degree	Note 2	
	θB		55	65	-			
	θL		55	65	-			
	θR		55	65	-			
Contrast Ratio	CR	θ=0°	300	400	-	-	Note1 Note3	
Response Time	T _{ON}	25°C		10	15	ms	Note1	
	T _{OFF}			15	25		Note4	
Chromaticity	White	Backlight is on	X	0.259	0.309	0.359		Note5 Note1
			Y	0.284	0.334	0.384		
	Red		X	0.550	0.600	0.650		
			Y	0.296	0.346	0.396		
	Green		X	0.283	0.333	0.383		
			Y	0.516	0.566	0.616		
	Blue		X	0.092	0.142	0.192		
			Y	0.065	0.115	0.165		
Uniformity	U	-	70	80	-	%	Note1 Note6	
NTSC	-	-	-	50	-	%	Note 5	
Luminance	L	-	350	400	-	cd/m ²	Note1 Note7	

Test Conditions:

1. The ambient temperature is 25±2°C .humidity is 65±7%
2. The test systems refer to Note 1 and Note 2.

Note 1: Definition of optical measurement system.

The optical characteristics should be measured in dark room. After 5 minutes operation, the optical properties are measured at the center point of the LCD screen. All input terminals LCD panel must be ground when measuring the center area of the panel.

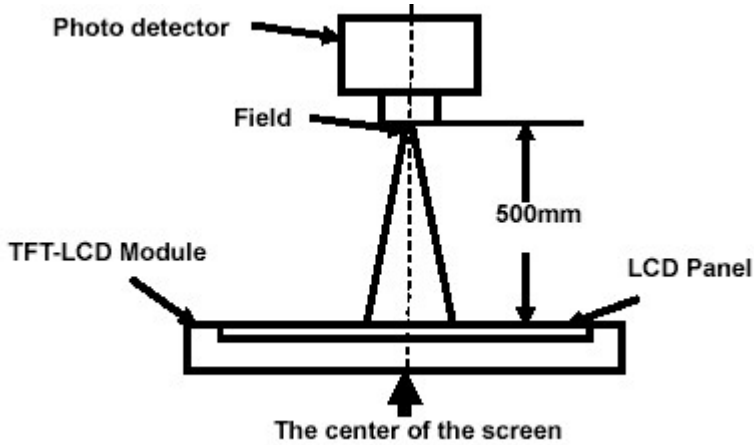

Item	Photo detector	Field
Contrast Ratio	SR-3A	1°
Luminance		
Chromaticity		
Lum Uniformity		
Response Time	BM-7A	2°

Note 2: Definition of viewing angle range and measurement system

viewing angle is measured at the center point of the LCD by CONOSCOPE(ergo-80).

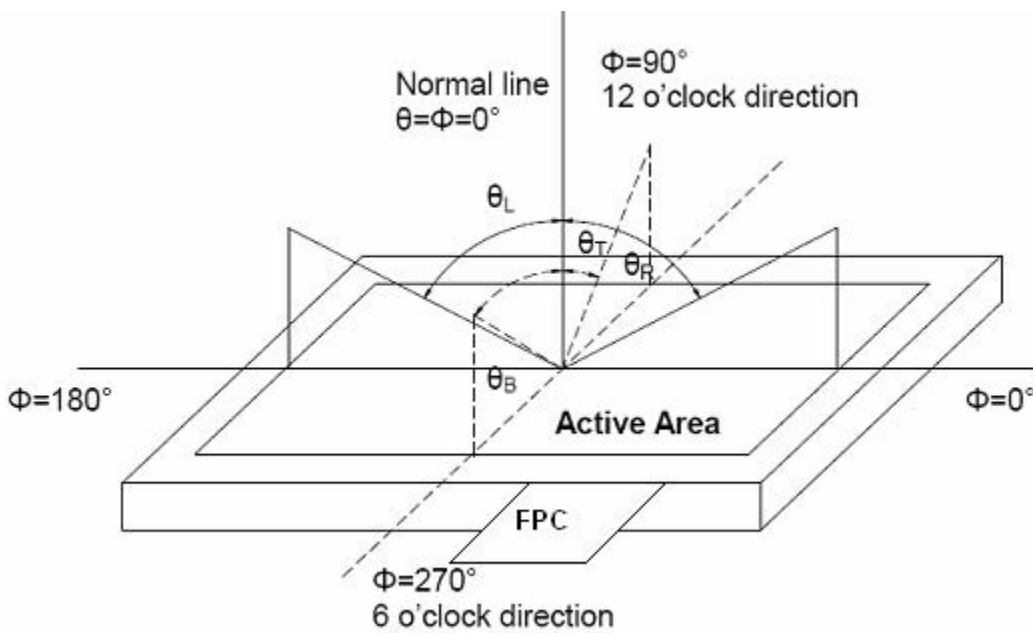

Note 3: Definition of contrast ratio

$$\text{Contrast ratio (CR)} = \frac{\text{Luminance measured when LCD is on the "White" state}}{\text{Luminance measured when LCD is on the "Black" state}}$$

White state “:The state is that the LCD should driven by Vwhite.

“Black state”: The state is that the LCD should driven by Vblack.

Vwhite: To be determined Vblack: To be determined.

Note 4: Definition of Response time

The response time is defined as the LCD optical switching time interval between “White” state and “Black” state. Rise time (TON) is the time between photo detector output intensity changed from 90% to 10%. And fall time (TOFF) is the time between photo detector output intensity changed from10% to 90%.

Note 4: Definition of Response time

The response time is defined as the LCD optical switching time interval between “White” state and “Black” state. Rise time (TON) is the time between photo detector output intensity changed from 90% to 10%. And fall time (TOFF) is the time between photo detector output intensity changed from 10% to 90%.

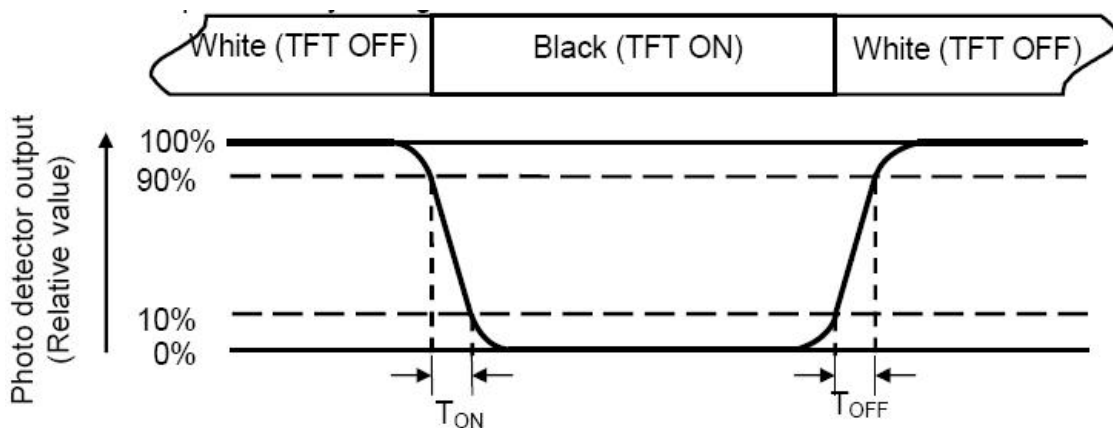

Note 5: Definition of color chromaticity (CIE1931)

Color coordinates measured at center point of LCD.

Note 6: Definition of Luminance Uniformity

Active area is divided into 9 measuring areas (Refer Fig. 2). Every measuring point is placed at the center of each measuring area.

Luminance Uniformity(U) = L_{min} / L_{max}

L-----Active area length W----- Active area width

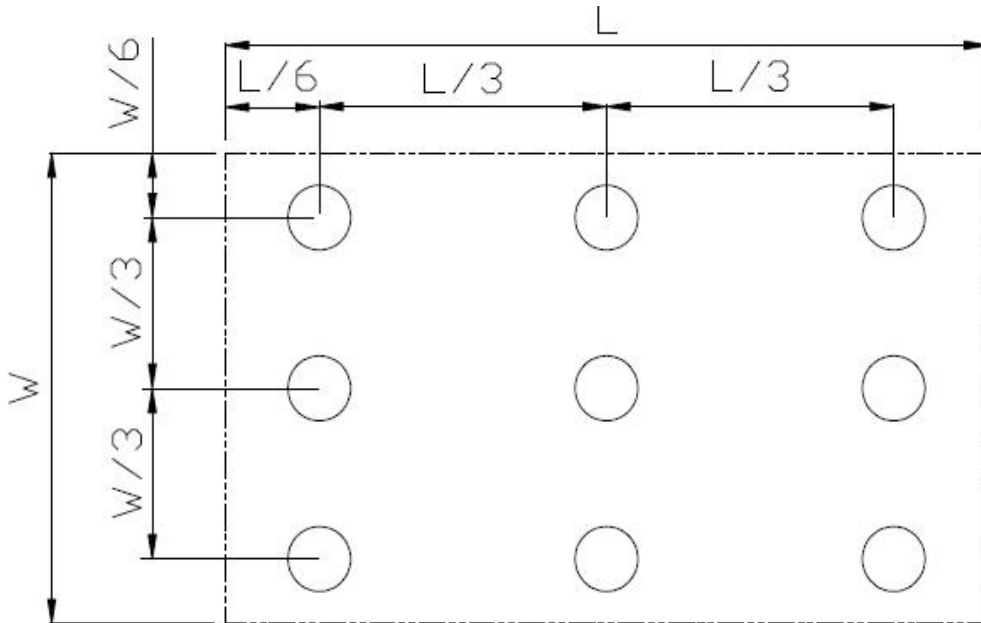

Definition of uniformity

L_{max} : The measured maximum luminance of all measurement position.

L_{min} : The measured minimum luminance of all measurement position.

Note 7: Definition of Luminance :

Measure the luminance of white state at center point.

8. Parts

8.1 Major Part List

Item	Part No.	Supplier	Reference No.
TFT Panel	P18311010	Tianma	TM104SDH01

9. Packing

9.1 Inside of Packing

Packing-box partitions as 20x1 slot.
 Each slot holds a LCD module with anti-static bag.
 One Packing-box holds up-to 20 LCD modules

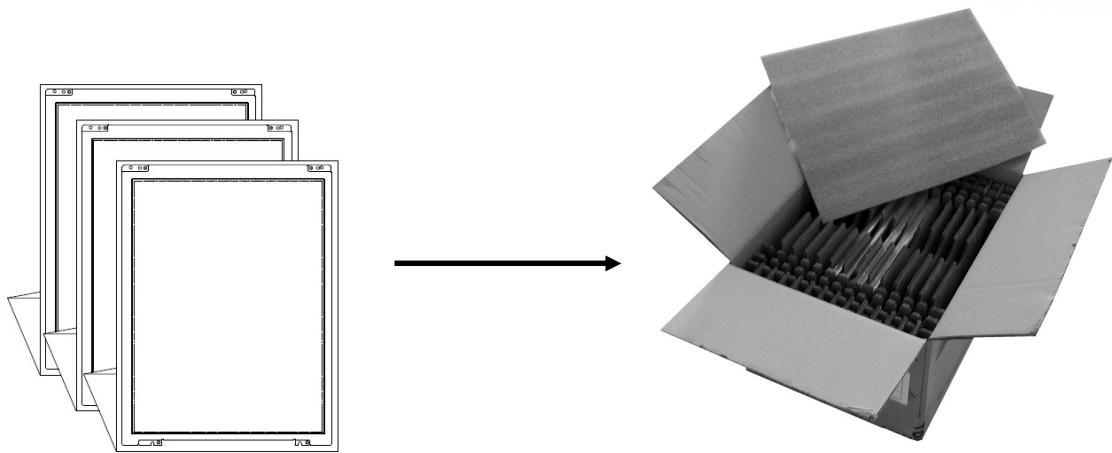

9.2 Outside of Packing-Box

A label on the side shows the content details



TOPWAY TECHNOLOGY CO., LTD
 深圳市拓普微科技开发有限公司

<input checked="" type="checkbox"/> LCM	<input type="checkbox"/> LCD	<input type="checkbox"/> _____
Model Name	LMT104SDH01	
Ref. No.	XXXXXXXXXX	
Lot No.	XXXXXXXXXX	
Qty	20PCS	Q.C. PASS
		Date 201X-XX-XX

www.topwaysz.com

www.displaydisplay.com

10. Environmental / Reliability Test

No	Test Item	Condition	Remark
1	High Temperature Operation	Ts=+70°C, 240hrs	
2	Low Temperature Operation	Ta=-20°C, 240hrs	
3	High Temperature Storage (non-operation)	Ta=+80°C, 240hrs	
4	Low Temperature Storage (non-operation)	Ta=-30°C, 240hrs	
5	High Temperature & High Humidity Operation	Ta = +60°C, 90% RH max,240 hours	
6	Thermal Shock (non-operation)	-20°C 30 min~+70°C 30 min, Change time:5min, 100 Cycles	
7	Electro Static Discharge (operation)	C=150pF,R=330Ω, Air:±15Kv, Contact:±8Kv, 10times/terminal	
8	Vibration (non-operation)	Frequency range:10~55Hz, Stroke:1.5mm Sweep:10Hz~55Hz~10Hz 2hours for each direction of X.y.z (6 hours for total)	
9	Shock (non-operation)	80G 6ms, ±X,±Y,±Z 3 times for each direction	
10	Package Drop Test	Height:80 cm,1 corner, 3 edges, 6 surfaces	
11	Package Vibration Test	Random Vibration: 0.015GxG/Hz for 5-200Hz, -6dB/Octave from 200-500Hz 2 hours for each direction of X,Y,Z (6 hours for total)	IEC60068-2-34

Note1: Ts is the temperature of panel's surface.

Note2: Ta is the ambient temperature of sample.

A	K1 Terminal No.	Pin Name
	1	VDD
	2	VDD
	3	GND
	4	GND
	5	IN0-
	6	IN0+
	7	GND
	8	IN1-
	9	IN1+
	10	GND
	11	IN2-
	12	IN2+
	13	GND
	14	CLK-
	15	CLK+
	16	GND
	17	NC
	18	NC
	19	GND
	20	GND

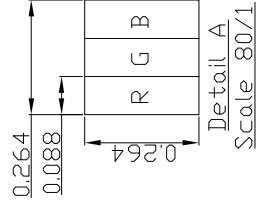
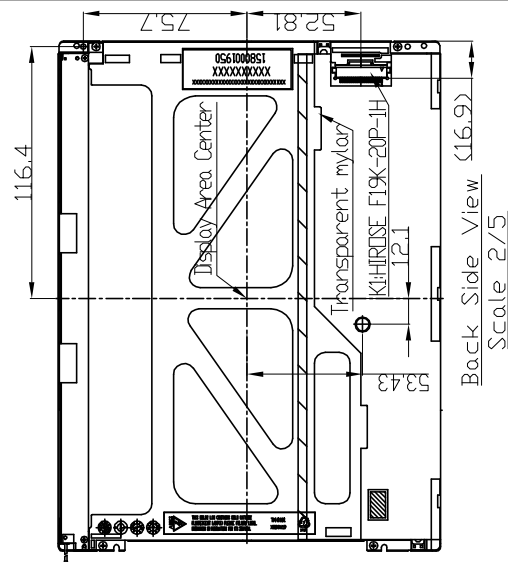
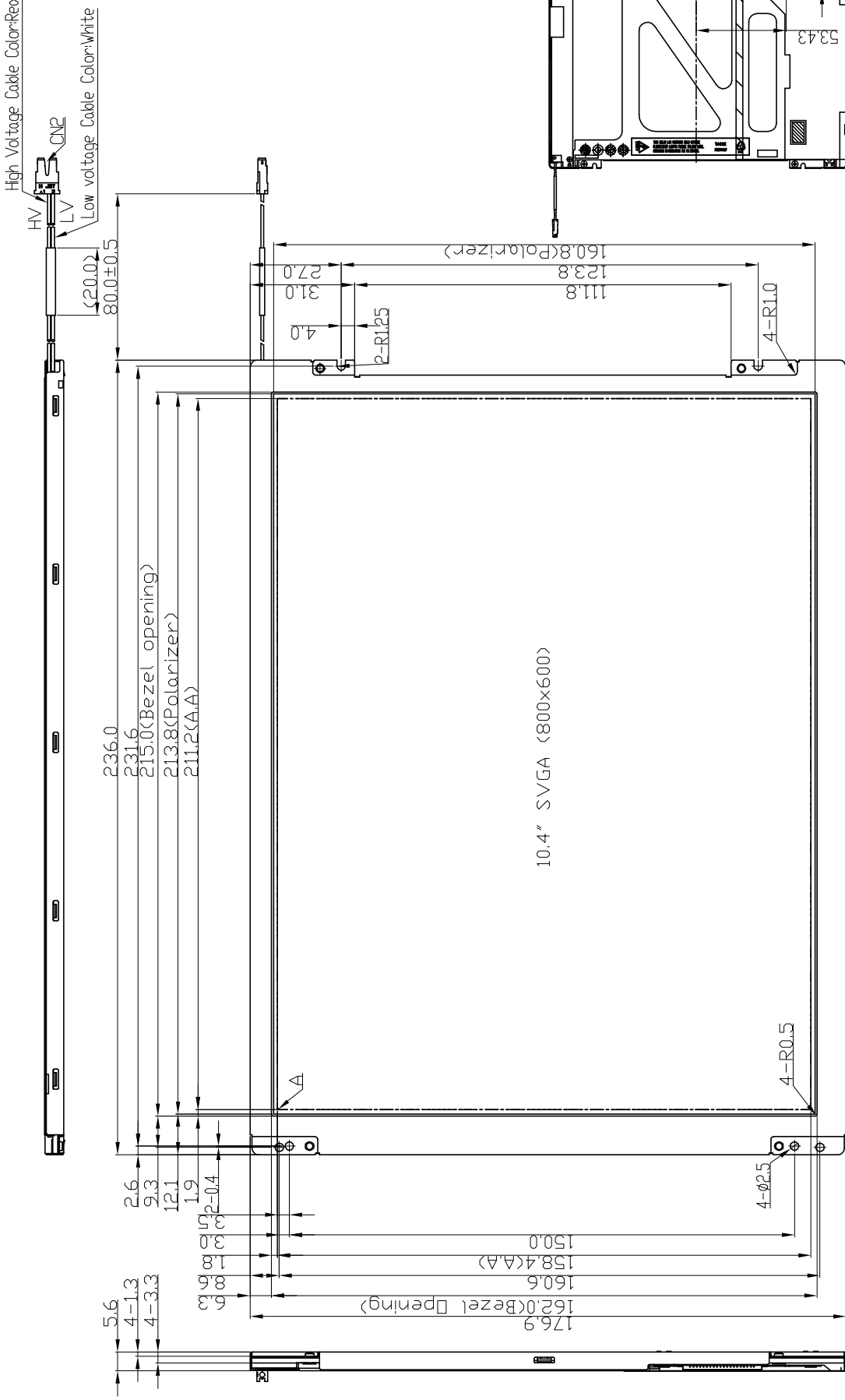

- Note: **A**
- *1. LCD Display Type : TFT, Transmissive
 - *2. Pixel Arrangement : RGB-STRIPE
 - *3. Supply Voltage : 3.3V
 - *4. Backlight Supply : 120mA (19.2V TYP.)
 - *5. Operating Temperature : -20°C~70°C
 - *6. Storage Temperature : -30°C~80°C
 - *7. Connector type : K1(20pin) connector : HIROSE DF19K-20P-1H (or equivalent) CN2(BACKLIGHT) connector : JST BHSR-02VS-1 (or equivalent) MATING connector : JST SM02B-BHSS-1-TB (or equivalent)

A	Refine Drawing	Jing Junjie	2014-07-19
	Rev/Note		Date
	Dwg Title	LMT104SDH01 Outline Dwg	
	Dwg No.	MK-003046a-1-1	Date
	Scale	2/1	Unit
	Tol.	±0.5	mm
	Checked		Paper Size
	Approved		A3
	Drawn	ChengYuan	

TOPWAY