



深圳市拓普微科技开发有限公司

SHENZHEN TOPWAY TECHNOLOGY CO., LTD.

LMT121DNGFWD-NNC

LCD Module User Manual

Prepared by: CaiSiqing Date: 2023-10-24	Checked by: Date:	Approved by: Date:
--	----------------------------------	-----------------------------------

Rev.	Descriptions	Edit	Release Date
0.1	Preliminary release	Lin Li	2019-06-24
0.2	Revise outline dwg	Cai Siqing	2023-10-24

Table of Content

1. General Specification	3
2. Block Diagram	3
3. Terminal Function	4
3.1 K1 TFT Input Terminal (MSB240420HE)	4
3.2 K2 Backlight Terminal(MSB24038P5)	4
3.3 K3 Capacitive Touch Panel Terminal(USB TYPE-C)	4
4. Absolute Maximum Ratings	5
5. Electrical Characteristics	5
5.1 Driving TFT LCD Panel	5
5.2 Driving For Backlight	6
5.3 Capacitive Touch Panel	6
5.4 Power supply voltage Sequence	7
6. AC Characteristics	8
6.1 Input data mapping	8
6.2 Timing Characteristics	9
6.3 Input signal timing chart	9
7. Physical Characteristics	10
7.1 Optical Characteristics	10
8. LCD Module Design and Handling Precautions	12
9. CTP Mounting Instructions	13
10. RTP Mounting Instructions	14

1. General Specification

TFT Interface :	LVDS (24bit or 18bit VESA)
CTP Interface:	USB
Display Technology :	a-Si TFT active matrix
Display Mode :	Transmissive / Normal White
Screen Size(Diagonal) :	12.1"
Outline Dimension :	293.0x 232.0 x 16.3 (mm) (see attached drawing for details)
Active Area :	245.76 x 184.32 (mm)
Number of dots :	1024 x 3 (RGB) x 768
Pixel Pitch :	0.240 x 0.240 (mm)
Pixel Configuration :	RGB Vertical Stripe
Backlight :	LED
Viewing Direction :	6 o'clock(Gray scale Inversion) (*1) 12 o'clock (*2)
Operating Temperature :	-20 ~ +70°C
Storage Temperature :	-30 ~ +80°C

Note:

- *1. For saturated color display content (eg. pure-red, pure-green, pure-blue or pure-colors-combinations).
- *2. For "color scales" display content.
- *3. Color tone may slightly change by temperature and driving condition.

2. Block Diagram

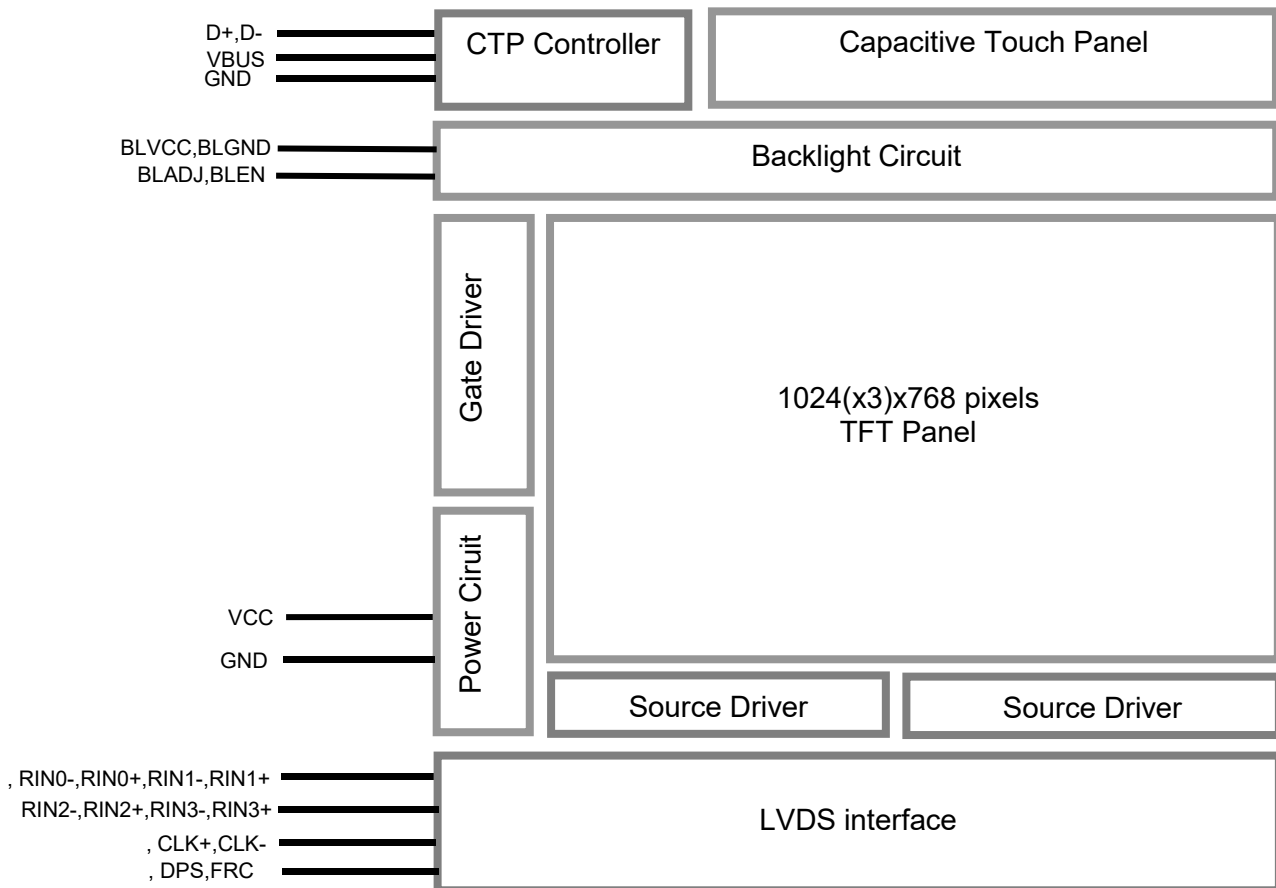

3. Terminal Function

3.1 K1 TFT Input Terminal (MSB240420HE)

Pin No.	Pin Name	I/O	Descriptions	
			Input data signal: 8bit	Input data signal:6bit
1	VCC	Power	Power Supply(3.3V)	
2	VCC			
3	GND	Power	Ground(0V)	
4	FRC	Input	High	Low or Open
5	RIN 0-	Input	LVDS receiver negative signal channel 0	
6	RIN 0+	Input	LVDS receiver positive signal channel 0	
7	GND	Power	Ground(0V)	
8	RIN 1-	Input	LVDS receiver negative signal channel 1	
9	RIN 1+	Input	LVDS receiver positive signal channel 1	
10	GND	Power	Ground(0V)	
11	RIN 2-	Input	LVDS receiver negative signal channel 2	
12	RIN 2+	Input	LVDS receiver positive signal channel 2	
13	GND	Power	Ground(0V)	
14	CLKIN-	Input	LVDS receiver negative signal clock	
15	CLKIN+	Input	LVDS receiver positive signal clock	
16	GND	Power	Ground(0V)	
17	RIN 3-	Input	LVDS receiver negative signal channel 3	Ground(0V)
18	RIN 3+	Input	LVDS receiver positive signal channel 3	
19	DPS	Input	Selection of scan direction High: Reverse scan Low or Open: Normal scan	
20	NC	--	--	

3.2 K2 Backlight Terminal(MSB24038P5)

Pin No	Pin Name	I/O	Descriptions
1	NC	--	No connection
2	BLADJ	Input	PWM Luminance control Hi:100%Drive Lo:0% Drive
3	BLEN	Input	Backlight ON/OFF control:5V-On/0v-Off
4	BLGND	Power	Ground(0V)
5	BLVCC	Power	Backlight Power Supply(12V)

3.3 K3 Capacitive Touch Panel Terminal(USB TYPE-C)

Pin No.	Pin Name	IO	Descriptions
A1/B12	GND	Power	Power Supply GND (0V)
A4/B9	VBUS	Power	Positive Power Supply(5.0V)
A5	NC	-	No connection
B8	NC	-	No connection
B7	D-	I/O	USB D- Signal
A6	D+	I/O	USB D+ Signal
B6	D+	I/O	USB D+ Signal
A7	D-	I/O	USB D- Signal
B5	NC	-	No connection
A8	NC	-	No connection
B4/A9	VBUS	Power	Positive Power Supply(5.0V)
A12/B1	GND	Power	Power Supply GND (0V)

4. Absolute Maximum Ratings

Items		Symbol	Rating	Unit	Remarks	
Power supply voltage	LCD panel signal processing board	VCC	-0.3 to +3.96	V	Ta= 25°C	
	LED driver	BLVCC	-0.3 to (+15.0)			
Input voltage for signals	Display signals ,Note1	VD	-0.5 to 3.96	V		
	Function signals ,Note2	VF	-0.5 to 3.96	V		
	Function signal for LED driver	BLADJ	-0.3 to (+15.0)	V		
		BLEN	-0.3 to (+15.0)	V		
Storage temperature		Tst	-30 to +80	°C		-
Operating temperature	Front surface	TopF	-20 to +70	°C		Note3
	Rear surface	TopR	-20 to +70	°C	Note4	
Relative humidity Note5		RH	90	%	Ta ≤ 40°C	
			85	%	40°C < Ta ≤ 50°C	
Absolute humidity ,Note5		AH	70,Note6	g/m3	Ta > 50°C	

Note1:RIN0±,RIN1±,RIN2±,RIN3± and CLKIN±;

Note2:DPS and FRC;

Note3:Measured at LCD panel surface (including self-heat);

Note4:Measured at LCD module's rear shield surface (including self-heat);

Note5:No condensation;

Note6:Water amount at Ta= 50°C and RH= 85%.

5. Electrical Characteristics

5.1 Driving TFT LCD Panel

Ta=25°C

Items	Symbol	MIN.	TYP.	MAX.	Unit	Note
Power supply voltage	VCC	3.0	3.3	3.6	V	
Power supply current	ICC	-	300	740	mA	*1
Permissible ripple voltage	VRP	-	-	300	mV	For VCC
Differential input threshold voltage for LVDS receiver	VTL	-100	-	-	mV	VCM=1.25V,*2
	VTH	-	-	100	mV	
Terminating resistor	RT	-	100	-	Ω	
Input voltage for DPS and FRC signals	VFH	0.7VCC	-	VCC	V	
	VFL	0	-	0.3VCC	V	

Note:

*1: All black pattern

*2: Common mode voltage for LVDS receiver

5.2 Driving For Backlight

BLGND=0V,Top=25°C

Parameter	Symbol	MIN.	TYP.	MAX.	Unit	Note
Power supply voltage	BLVCC	10.8	12.0	13.2	V	Note 1
Power supply voltage	I _{BLVCC}	-	430	650 Note2	mA	At the maximum luminance control
Permissible ripple voltage	VRPD	-	-	200	mVp-p	For BLVCC,Note3
Input voltage for PWM signal	VDFH1	2.0	-	BLVCC	V	
	VDFL1	0	-	0.8	V	
Input voltage for BLEN signal	VDFH2	2.0	-	BLVCC	V	
	VDFL2	0	-	0.8	V	
PWM Input Frequency	f _{PWM}	200	-	20k	Hz	Note4,Note5
PWM duty ratio	DR _{PWM}	1	-	100	%	Note6,Note7
PWM pulse width	t _{PWH}	5	-	-	us	

Note1:When designing of the power supply ,take the measures for the prevention of surge voltage.

Note2:This value excludes peak current such as overshoot current.

Note3:This power supply lines(BLVCC and GND)may have ripple voltage during luminance control of LED.There is the possibility that the ripple voltage produces acoustic noise and signal wave noise in audio circuit and so on.Put a capacitor between the power supply lines(BLVCC and GND) to reduce the noise is necessary .

Note4:A recommended f_{PWM} value is as follows.

$$f_{PWM} = (2n-1) * f_v/4$$

(n =integer,f_v =frame frequency of LCD module)

Note5:Depending on the frequency used ,some noise may appear on the screen,please conduct a thorough evaluation,

Note6:While the BLEN signal is high ,do not set the t_{PWH}(PWM pulse width) is less than 5us .It may cause abnormal working is the backlight .In this case,turn the backlight off and then on again by BLEN signal.

Note7:Regardless of the PWM frequency,both PWM duty ratio and PWM pulse width must be always more than the minimum values

5.3 Capacitive Touch Panel

T_A=25°C

Items	Symbol	MIN.	TYP.	MAX.	Unit	Note
Power supply voltage	5V	4.5	5.0	5.5	V	
Power supply current	I _{5V}	-	95.0	-	mA	

5.4 Power supply voltage Sequence

5.4.1 LCD panel signal processing board

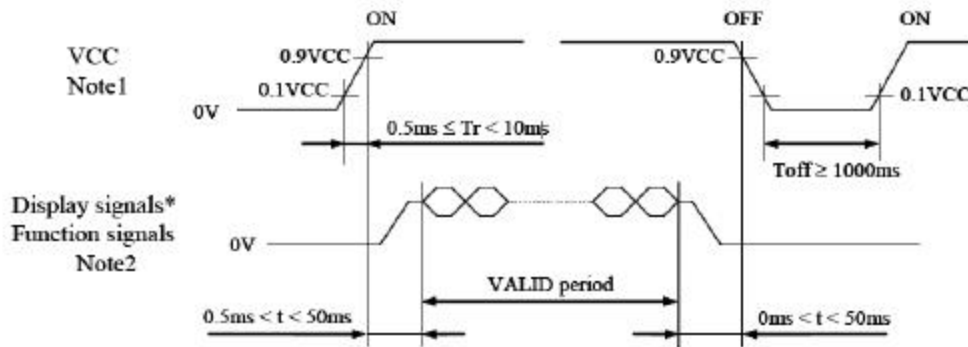

* These signals should be measured at the terminal of 100Ω resistance.

Note1: If there is a voltage variation(voltage drop) at the rising edge of VCC below 3.0V,there is a possibility that a product does not work due to a protection circuit.

Note2: Display signals (RIN0±,RIN1±,RIN2±,RIN3± and CLKIN±) and function signals(DPS and FRC) must be set to Low or High-impedance, except the VALID period (See above sequence diagram),in order to avoid the circuitry damage .If some of display and function signals of this product are cut while this product is working, even if the signal input to it once again, it might not work normally. If a customer stops the display and function signals, VCC also must be shut down.

5.4.2 LED Driver

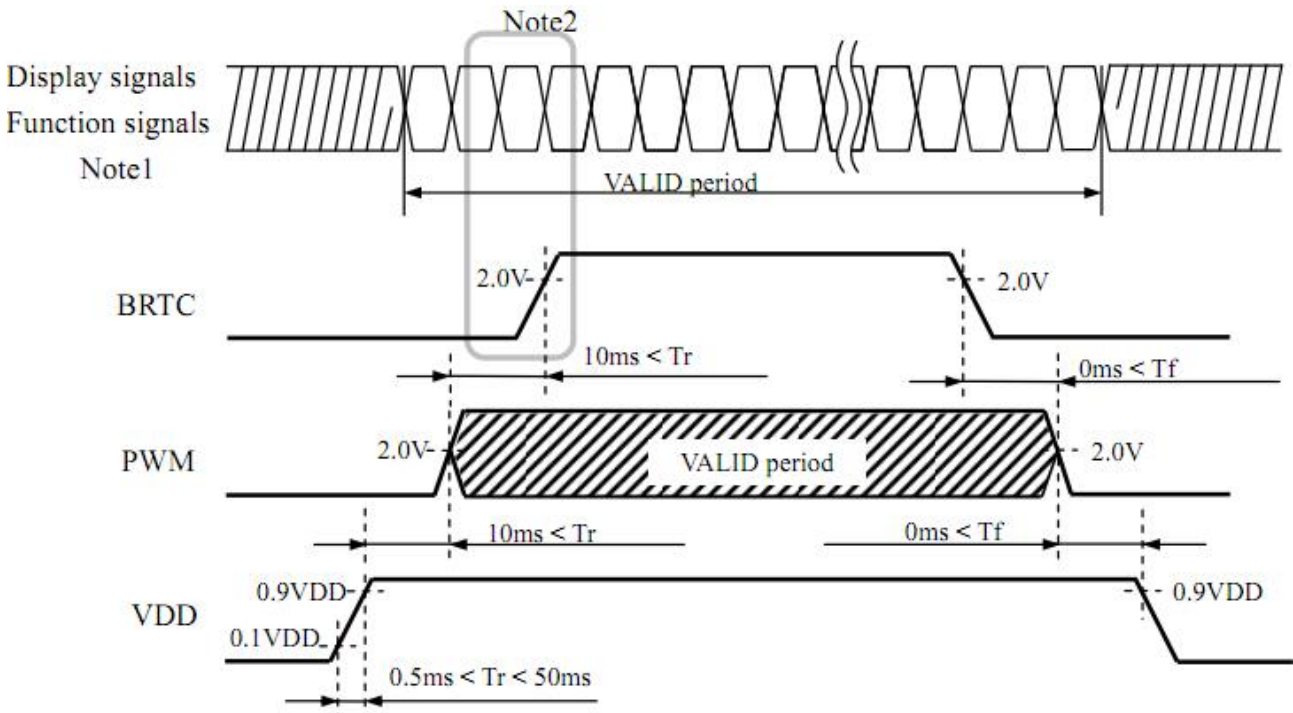

Note1:These are the display and function signals for LCD panel signal processing board.

Note2:The backlight should be turned on within the valid period of display and function signals,in order to avoid unstable data display.

6. AC Characteristics

6.1 Input data mapping

(1) LVDS Input data signal: 8-bit

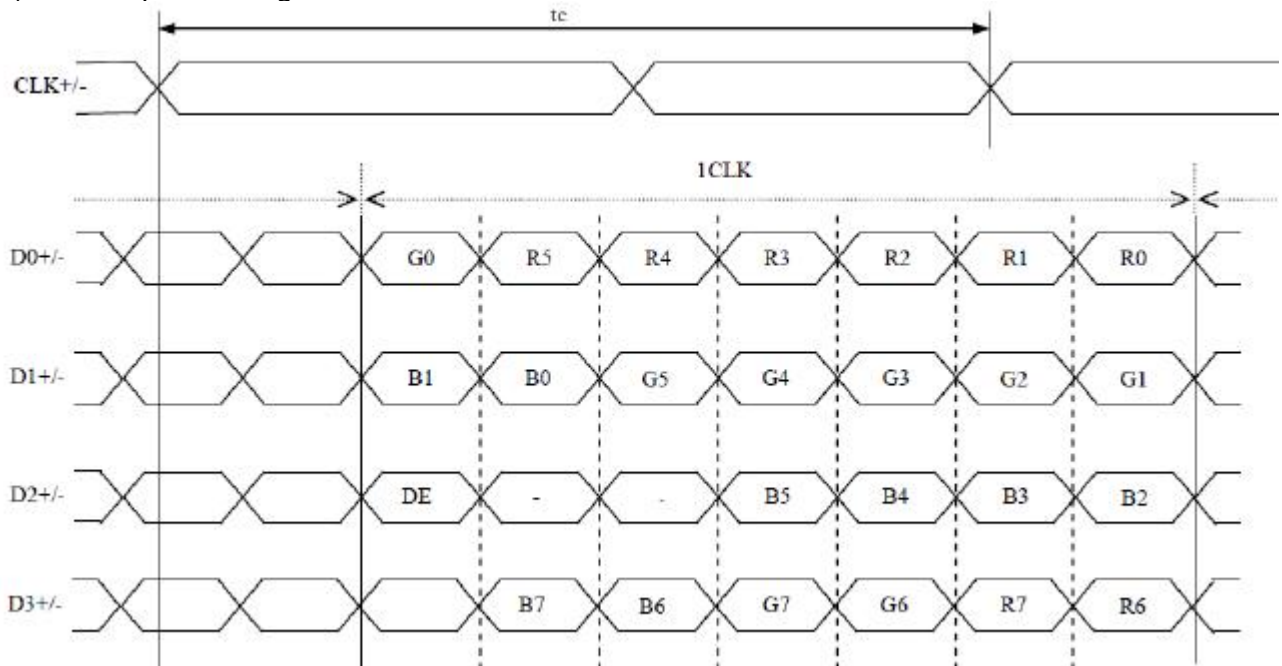

(2) LVDS Input data signal: 6-bit

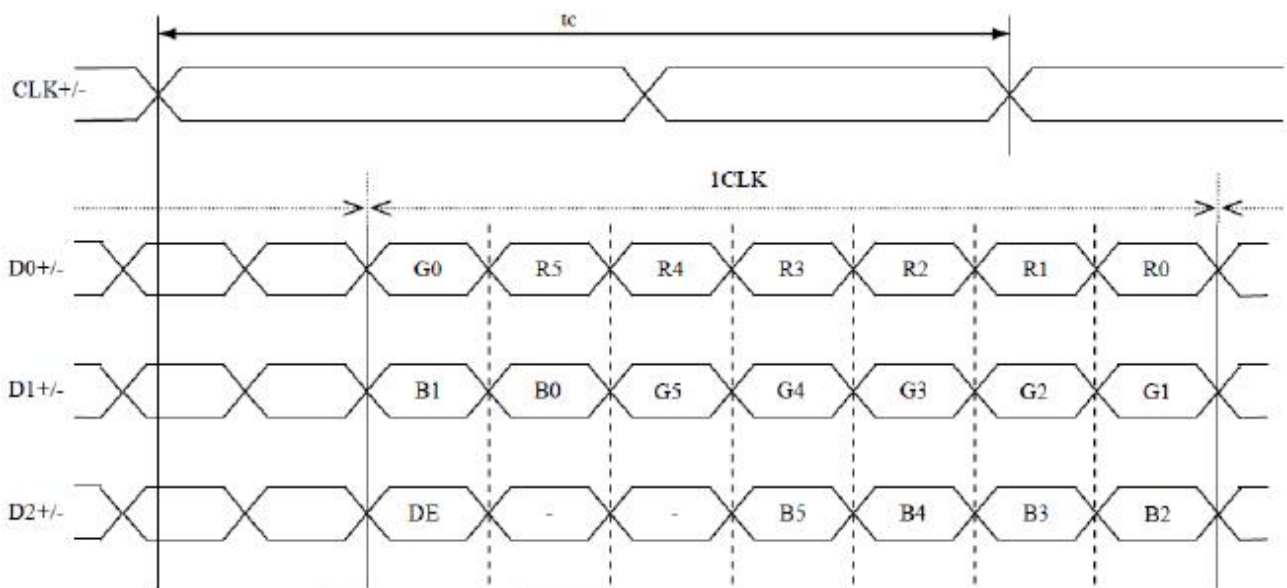

6.2 Timing Characteristics

(Note1,Note2,Note3)

Parameter		Symbol	MIN.	TYP.	MAX.	Unit	Remarks	
CLK	Frequency	1/tc	52.0	65.0	71.0	MHz	15.385ns (typ.)	
	Duty ratio	-				-	-	
	Rise time, Fall time	-				ns	-	
DATA	CLK-DATA	Setup time	-			ns	-	
		Hold time	-			ns	-	
	Rise time, Fall time	-				ns	-	
DE	Horizontal	Cycle	th	16.542	20.676	26.88	us	48.363kHz (typ.)
				1114	1344	1400	CLK	
		Display period	thd	1024			CLK	-
	Vertical (One frame)	Cycle	tv	13.34	16.666	20.0	ms	60.0Hz (typ.)
				780	806	845	H	
		Display period	tvd	768			H	-
	CLK-DE	Setup time	-			-	ns	-
		Hold time	-			-	ns	-
	Rise time, Fall time	-				ns	-	

Note1:Definition of parameter is as follows.

tc = 1CLK, th = 1H

Note2:See the data sheet of LVDS transmitter.

Note3:Vertical cycle (tv) should be specified in integral multiple of Horizontal cycle (th).

6.3 Input signal timing chart

Horizontal timing

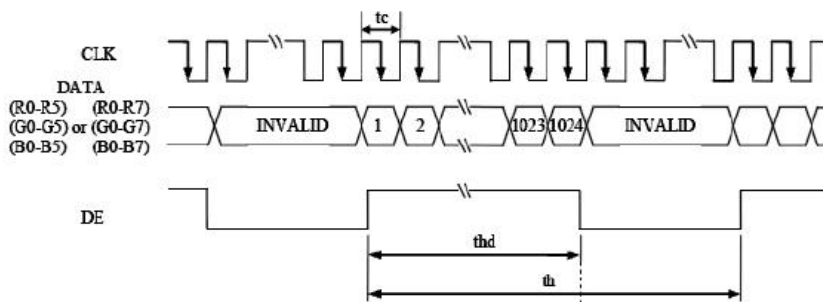

Vertical timing

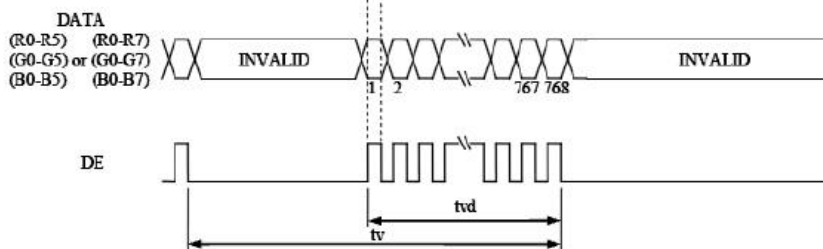

7. Physical Characteristics

7.1 Optical Characteristics

(Note*1,*2)

Parameter	Condition	Symbol	min.	typ.	max.	Unit	Measuring instrument	Remarks	
Luminance	White at center $\theta R=0^\circ, \theta L=0^\circ, \theta U=0^\circ, \theta D=0^\circ$	L	250	350	-	cd/m ²	BM-5A	-	
Contrast ratio	White/Black at center $\theta R=0^\circ, \theta L=0^\circ, \theta U=0^\circ, \theta D=0^\circ$	CR	500	700	-	-	BM-5A	Note3	
Luminance uniformity	White $\theta R=0^\circ, \theta L=0^\circ, \theta U=0^\circ, \theta D=0^\circ$	LU	-	1.25	(1.33)	-	BM-5A	Note6	
Chromaticity	White	x coordinate	Wx	0.263	0.313	0.363	-	SR-3	Note5
		y coordinate	Wy	0.279	0.329	0.379	-		
	Red	x coordinate	Rx	-	TBD	-	-		
		y coordinate	Ry	-	TBD	-	-		
	Green	x coordinate	Gx	-	TBD	-	-		
		y coordinate	Gy	-	TBD	-	-		
Blue	x coordinate	Bx	-	TBD	-	-			
	y coordinate	By	-	TBD	-	-			
Color gamut	$\theta R=0^\circ, \theta L=0^\circ, \theta U=0^\circ, \theta D=0^\circ$ at center, against NTSC color space	C	48	55	-	%			
Response time	White to Black	Ton	-	(3)	(5)	ms	BM-5A -10000	Note4	
	Black to White	Toff	-	(5)	(8)	ms			
Viewing angle	Right	$\theta U=0^\circ, \theta D=0^\circ, CR \geq 10$	θR	70	80	-	EZ Contrast	Note2	
	Left	$\theta U=0^\circ, \theta D=0^\circ, CR \geq 10$	θL	70	80	-			
	Up	$\theta R=0^\circ, \theta L=0^\circ, CR \geq 10$	θU	70	80	-			
	Down	$\theta R=0^\circ, \theta L=0^\circ, CR \geq 10$	θD	70	80	-			

Note:

*1. The value above are initial Characteristics.

* 2: Measurement conditions are as follows.

Ta= 25°C, VCC= 3.3V, VDD= 12.0V, PWM duty ratio: 100%,

Display mode: XGA, Horizontal cycle= 1/48.363kHz, Vertical cycle= 1/60.0Hz,

DPS= Low or Open: Normal scan, FRC= High

Note 1:

The data are measured after LEDs are turned on for 5 minutes. LCM displays full white. The brightness is the average value of 9 measured spots. Measurement equipment SR-3A (1°)

Measuring condition:

- Measuring surroundings: Dark room
- Measuring temperature: Ta=25°C.
- Adjust operating voltage to get optimum contrast at the center of the display.

Note 2:

The definition of viewing angle:

Refer to the graph below marked by θ and ϕ

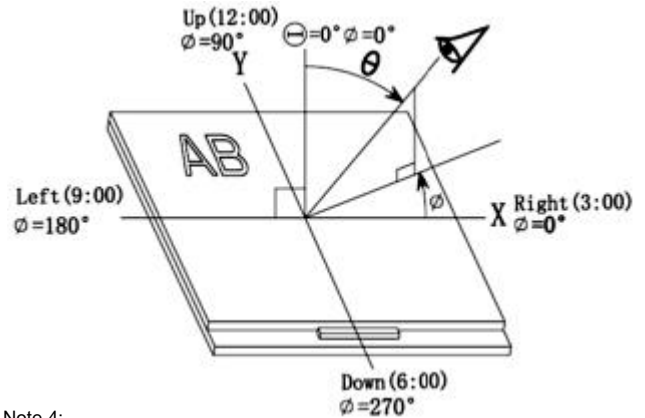

Note 3:

The definition of contrast ratio (Test LCM using SR-3A (1°)):

$$\text{Ratio(CR)} = \frac{\text{Luminance When LCD is at "White" state}}{\text{Luminance When LCD is at "Black" state}} \times 100\%$$

(Contrast Ratio is measured in optimum common electrode voltage)

Note 4:

Definition of Response time. (Test LCD using BM-7A(2°)):

The output signals of photo detector are measured when the input signals are changed from "black" to "white"(falling time) and from "white" to "black"(rising time), respectively.

The response time is defined as the time interval between the 10% and 90% of amplitudes. Refer to figure as below.

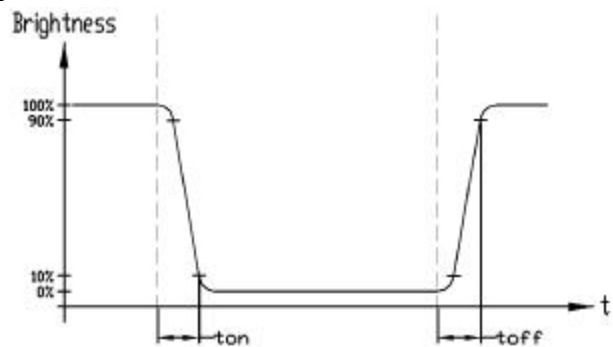

Note 5:

Definition of Color of CIE1931 Coordinate and NTSC Ratio

Color gamut:

$$S = \frac{\text{Area of RGB triangle}}{\text{Area of NTSC triangle}} \times 100\%$$

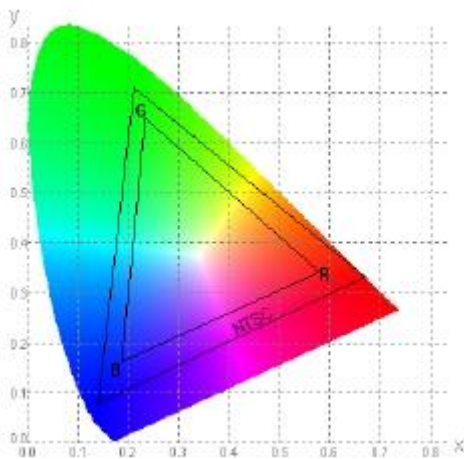

Note 6:

The luminance uniformity is calculated by using following formula

$$B_p = B_p (\text{Min.}) / B_p (\text{Max.}) \times 100 (\%)$$

Bp (Max.) = Maximum brightness in 9 measured spots

Bp (Min.) = Minimum brightness in 9 measured spots.

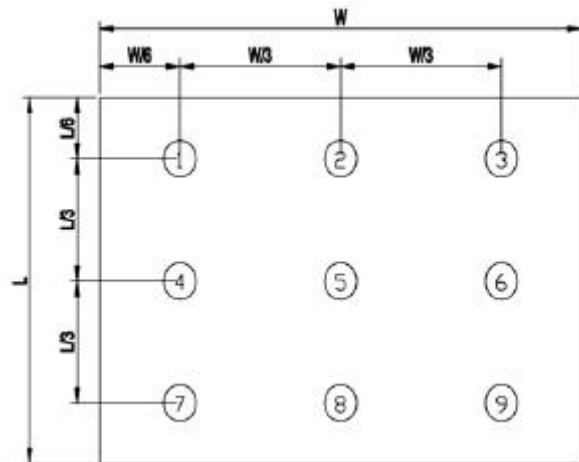

Note 7:

Measured the luminance of white state at center point

8. LCD Module Design and Handling Precautions

- Please ensure V0, VCOM is adjustable, to enable LCD module get the best contrast ratio under different temperatures, view angles and positions.
- Normally display quality should be judged under the best contrast ratio within viewable area. Unexpected display pattern may com out under abnormal contrast ratio.
- Never operate the LCD module exceed the absolute maximum ratings.
- Never apply signal to the LCD module without power supply.
- Keep signal line as short as possible to reduce external noise interference.
- IC chip (e.g. TAB or COG) is sensitive to light. Strong light might cause malfunction. Light sealing structure casing is recommended.
- Make sure there is enough space (with cushion) between case and LCD panel, to prevent external force passed on to the panel; otherwise that may cause damage to the LCD and degrade its display result.
- Avoid showing a display pattern on screen for a long time (continuous ON segment).
- LCD module reliability may be reduced by temperature shock.
- When storing and operating LCD module, avoids exposure to direct sunlight, high humidity, high or low temperature. They may damage or degrade the LCD module.
- Never leave LCD module in extreme condition (max./min storage/operate temperature) for more than 48hr.
- Recommend LCD module storage conditions is 0 C~40 C <80%RH.
- LCD module should be stored in the room without acid, alkali and harmful gas.
- Avoid dropping & violent shocking during transportation, and no excessive pressure press, moisture and sunlight.
- LCD module can be easily damaged by static electricity. Please maintain an optimum anti-static working environment to protect the LCD module. (eg. ground the soldering irons properly)
- Be sure to ground the body when handling LCD module.
- Only hold LCD module by its sides. Never hold LCD module by applying force on the heat seal or TAB.
- When soldering, control the temperature and duration avoid damaging the backlight guide or diffuser which might degrade the display result such as uneven display.
- Never let LCD module contact with corrosive liquids, which might cause damage to the backlight guide or the electric circuit of LCD module.
- Only clean LCD with a soft dry cloth, Isopropyl Alcohol or Ethyl Alcohol. Other solvents (e.g. water) may damage the LCD.
- Never add force to components of LCD module. It may cause invisible damage or degrade the module's reliability.
- When mounting LCD module, please make sure it is free from twisting, warping and bending.
- Do not add excessive force on surface of LCD, which may cause the display color change abnormally.
- LCD panel is made with glass. Any mechanical shock (e.g. dropping from high place) will damage the LCD module.

8. 液晶显示模块设计和使用须知

- 请注意 V0, VCOM 的设定, 以确保液晶显示模块在不同的使用温度下以及在不同的视角和位置观察模块显示, 均能达到最佳对比度, 请务必将应用电路上设置为对比度可调。
- 请注意液晶显示模块的显示品质判定是指在正常对比度下以及视窗 (V. A) 范围内进行的, 非正常对比度下液晶可能会出现非预期的显示不良, 应注意区分。
- 请勿在最大额定值以外使用液晶显示模块。
- 请勿在没有接通电源的条件下, 给液晶显示模块输送信号。
- 请尽可能缩短信号线的连接, 以避免对液晶显示模块的信号干扰。
- 集成电路因 IC 芯片 (如 TAB 或 COG) 对紫外线极为敏感, 强光环境下可能会引起液晶显示模块功能失效, 故应采用不透光的外壳。
- 请在液晶显示模块与外壳之间保留足够的空间 (可使用衬垫), 以缓冲外力对液晶显示模块的损坏或因受力不均而产生的显示不匀等异常现象。
- 避免液晶显示屏在某一画面下长时间点亮, 否则有出现残影的风险; 请通过软件每隔一段时间改变一次画面。
- 液晶显示模块的可靠性可能因温度冲击而降低。
- 请勿在阳光直射、高湿、高温或低温下储存和使用液晶显示模块, 这将造成液晶显示模块的损坏或失效。
- 请勿在极限环境 (最大/最小存储/工作温度) 下使用或放置液晶显示模块超过 48 小时以上。
- 液晶显示模块建议存储条件为: 0 C~40 C <80%RH。
- 请勿让液晶显示模块存储于带有酸性、碱性, 有害气体环境之中。
- 在运输过程中, 请勿让液晶显示模块跌落与猛烈震动, 同时避免异常挤压, 高湿度, 与阳光照射。
- 液晶显示模块极易受静电损坏, 请务必保证液晶显示模块在防静电的工作环境中使用或保存。(如: 烙铁正确接地, 等)
- 拿取液晶显示模块时需注意操作人员的接地情况。
- 请手持液晶显示模块的边沿取放模块, 防止热压纸或 TAB 部位受力。
- 焊接液晶模块时, 请注意控制烙铁的温度、焊接时间, 以免烫坏导光板或偏光片, 导致显示不匀等不良现象发生。
- 请勿使用洗板水等腐蚀性液体接触液晶模块, 以免腐蚀导光板或模块电路。
- 仅可使用柔软的干布, 异丙醇或乙醇清洁液

- Protective film is attached on LCD screen. Be careful when peeling off this protective film, since static electricity may be generated.
- Polarizer on LCD gets scratched easily. If possible, do not remove LCD protective film until the last step of installation.
- When peeling off protective film from LCD, static charge may cause abnormal display pattern. The symptom is normal, and it will turn back to normal in a short while.
- LCD panel has sharp edges, please handle with care.
- Never attempt to disassemble or rework LCD module.
- If display panel is damaged and liquid crystal substance leaks out, be sure not to get any in your mouth, if the substance comes into contact with your skin or clothes promptly wash it off using soap and water.

9. CTP Mounting Instructions

9.1 Bezel Mounting (Figure 1)

- The bezel window should be bigger than the CTP active area. It should be $\geq 0.5\text{mm}$ each side.
- Gasket should be installed between the bezel and the CTP surface.
- The final gap should be about $0.5\sim 1.0\text{mm}$.
- It is recommended to provide an additional support bracket for backside support when necessary (e.g. slim type TFT module without mounding structure). They should only provide appropriate support and keep the module in place.
- The mounting structure should be strong enough to prevent external uneven force or twist act onto the module.

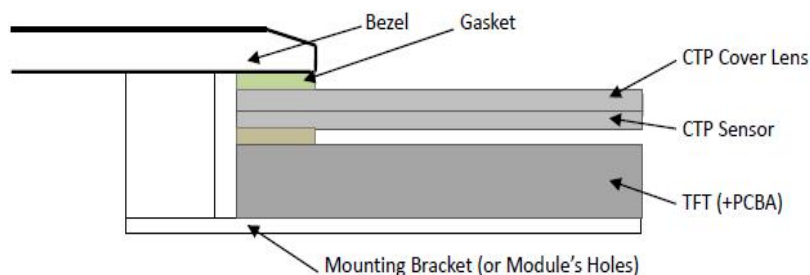

Figure 1

9.2 Surface Mounting (Figure 2)

- As the CTP assembling on the countersink area with double side adhesive.
- The countersink area should be flat and clean to ensure the double side adhesive installation result.
- The Bezel is recommend to keep a gap ($\geq 0.3\text{mm}$ each side) around the cover lens for tolerance.
- It is recommended to provide an additional support bracket with gasket for backside support when necessary (e.g. TFT module without mounding

晶屏表面, 其他任何溶剂(如:水)都有可能损坏液晶模块。

- 请勿挤压液晶显示模块上的元器件, 以避免产生潜在的损坏或失效而影响产品可靠性。
- 装配液晶显示模块时, 请务必注意避免液晶显示模块的扭曲或变形。
- 请勿挤压液晶显示屏表面, 这将导致显示颜色的异常。
- 液晶屏由玻璃制作而成, 任何机械碰撞(如从高处跌落)均有可能损坏液晶显示模块。
- 液晶屏表面带有保护膜, 揭除保护膜时需要注意可能产生的静电。
- 因液晶显示屏表面的偏光片极易划伤, 安装完成之前请尽量不要揭开保护膜。
- 请缓慢揭除保护膜, 在此过程中液晶显示屏上可能会产生静电, 此为正常情况, 可在短时间内消失。
- 请注意避免被液晶显示屏的边缘割伤。
- 请不要试图拆卸或改造液晶显示模块。
- 当液晶显示屏出现破裂, 内部液晶液体可能流出; 相关液体不可吞吃, 绝对不可接触嘴巴, 如接触到皮肤或衣服, 请使用肥皂与清水彻底清洗。

9. 电容触摸屏安装指导

9.1 面框安装 (附图 1)

- 客户面框窗口应大于 CTP 动作区域, 各边离动作区应 $\geq 0.5\text{mm}$ 。
- 面框与 CTP 面板间应垫有胶垫, 其最终间隙约为 $0.5\sim 1.0\text{mm}$ 。
- 建议必要时在背面提供附加支架(例如无安装结构的薄型 TFT 模块), 应仅利用适当支撑以保持模块位置。
- 安装结构应具有足够的强度, 以防止外部不均匀力或扭曲力作用到模块上。

9.2 嵌入安装 (附图 2)

- 客户面框应具有使用双面胶粘贴 CTP 的结构沉台面, 其粘贴面要求平整且洁净无污以保证粘贴牢靠。
- 考虑到制作误差, 建议面框与 CTP 盖板之间四周留有 $\geq 0.3\text{mm}$ 间隙。

- structure). They should only provide appropriate support and keep the module in place.
- The mounting structure should be strong enough to prevent external uneven force or twist act onto the module

- 建议必要时在背面提供垫有胶垫附加支架(例如无安装结构的 TFT 模块), 应仅利用适当支撑以保持模块位置.
- 安装结构应具有足够的强度, 以防止外部不均匀力或扭曲力作用到模块上.

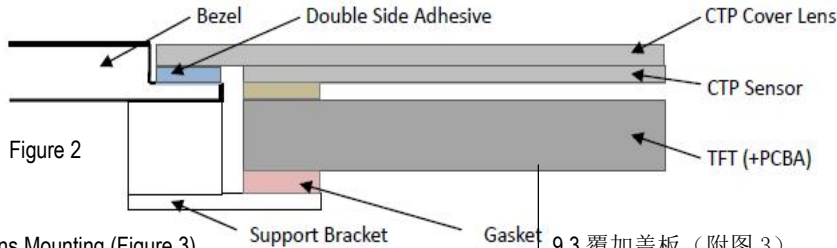

9.3 Additional Cover Lens Mounting (Figure 3)

- For the case of additional cover Lens mounting, it is necessary to recheck with the CTP specification about the material and thickness to ensure the functionality.
- It should keep a 0.2~0.3mm gap between the cover lens and the CTP surface..
- The cover lens window should be bigger than the active area of the CTP.It should be $\geq 0.5\text{mm}$ each side.
- It is recommended to provide an additional support bracket for backside support when necessary (e.g. slim type TFT module without mounding structure). They should only provide appropriate support and keep the module in place.
- The mounting structure should be strong enough to prevent external uneven force or twist act onto the module.

9.3 覆加盖板 (附图 3)

- 需要覆加玻璃盖板的安装, 为确保其功能, 有必要查看产品规格书中有关盖板材料和厚度的说明.
- 玻璃盖板与 CTP 表面之间应留有 0.2~0.3mm 间隙.
- 玻璃盖板视窗应大于 CTP 动作区域, 各边离动作区应 $\geq 0.5\text{mm}$.
- 建议必要时在背面提供附加支架(例如无安装结构的薄型 TFT 模块), 应仅利用适当支撑以保持模块位置.
- 安装结构应具有足够的强度, 以防止外部不均匀力或扭曲力作用到模块上.

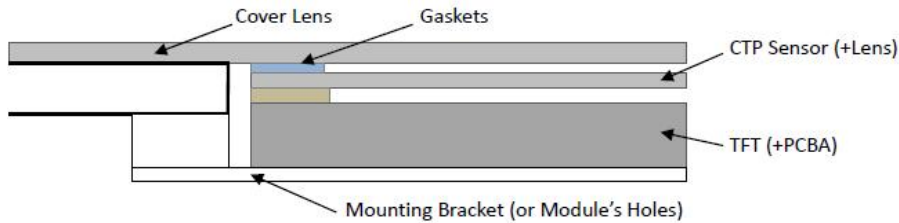

Figure 3

10. RTP Mounting Instructions

- It should bezel touching the RTP Active Area (A.A.) to prevent abnormal touch.It should left gab $D=0.2\sim 0.3\text{mm}$ in between. (Figure 4)
- Outer bezel design should take care about the area outside the A.A. Those areas contain circuit wires which is having different thickness. Touching those areas could de-form the ITO film. As a result bezel the ITO film be damaged and shorten its lifetime.
- It is suggested to protect those areas with gasket (between the bezel and RTP).The suggested figures are $B\geq 0.50\text{mm}$; $C\geq 0.50\text{mm}$. (Figure 4)
- The bezel side wall should keep space $E=0.2\sim 0.3\text{mm}$ from the RTP. (Figure

10. 电阻触摸屏安装指导

- 为避免面框直接压在动作区(A. A.)上造成误动作, 面框与电阻触摸屏(RTP)之间应留有一定的空隙 $D=0.2\sim 0.3\text{mm}$ 之间. (附图 4)
- 设计面框时, 要注意用面框保护触摸屏四周的非保证操作区域, 因为布线区域在此处形成一台阶, 在此区域附近操作时 ITO Film 变形较大, 容易导致 ITO 损坏而降低寿命。为保护 RTP 和避免误操作, 在 RTP 与面框之间垫缓冲物(Gasket), 我们建议设计面框应覆盖动作区的边缘, 面框边缘到 V. A. 区的距离 $B\geq 0.50\text{mm}$; 垫圈内边缘到 V. A. 区的距离 $C\geq 0.50\text{mm}$. (附图 4)
- 在设计面框与 RTP 组装时, 应考虑到面框内

4)

侧与 RTP 外侧的间距 $E \geq 0.2\text{mm}$. (附图 4)

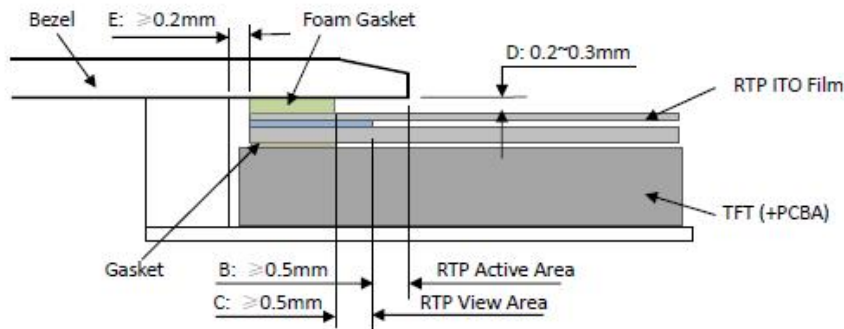

Figure 4

- In general design,
 - RTP V.A. should be bigger than the TFT V.A.
 - and RTP A.A. should be bigger than the TFT A.A.
- (Figure 5)

- 通常设计时:
 - RTP 的可视区 V. A. 应不小于 TFT 的可视区 V. A.
 - 及 RTP 的动作区 A. A. 应不小于 TFT 的动作区 A. A.
- (附图 5)

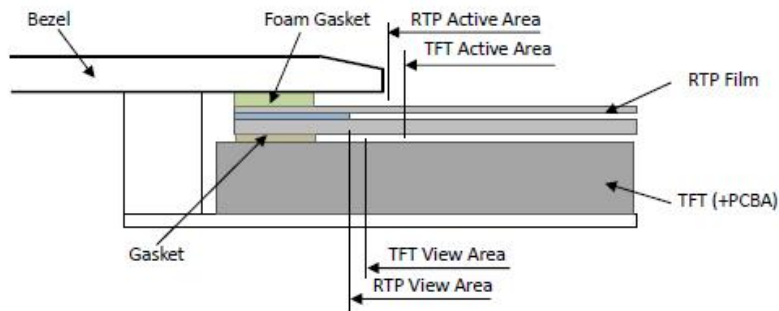
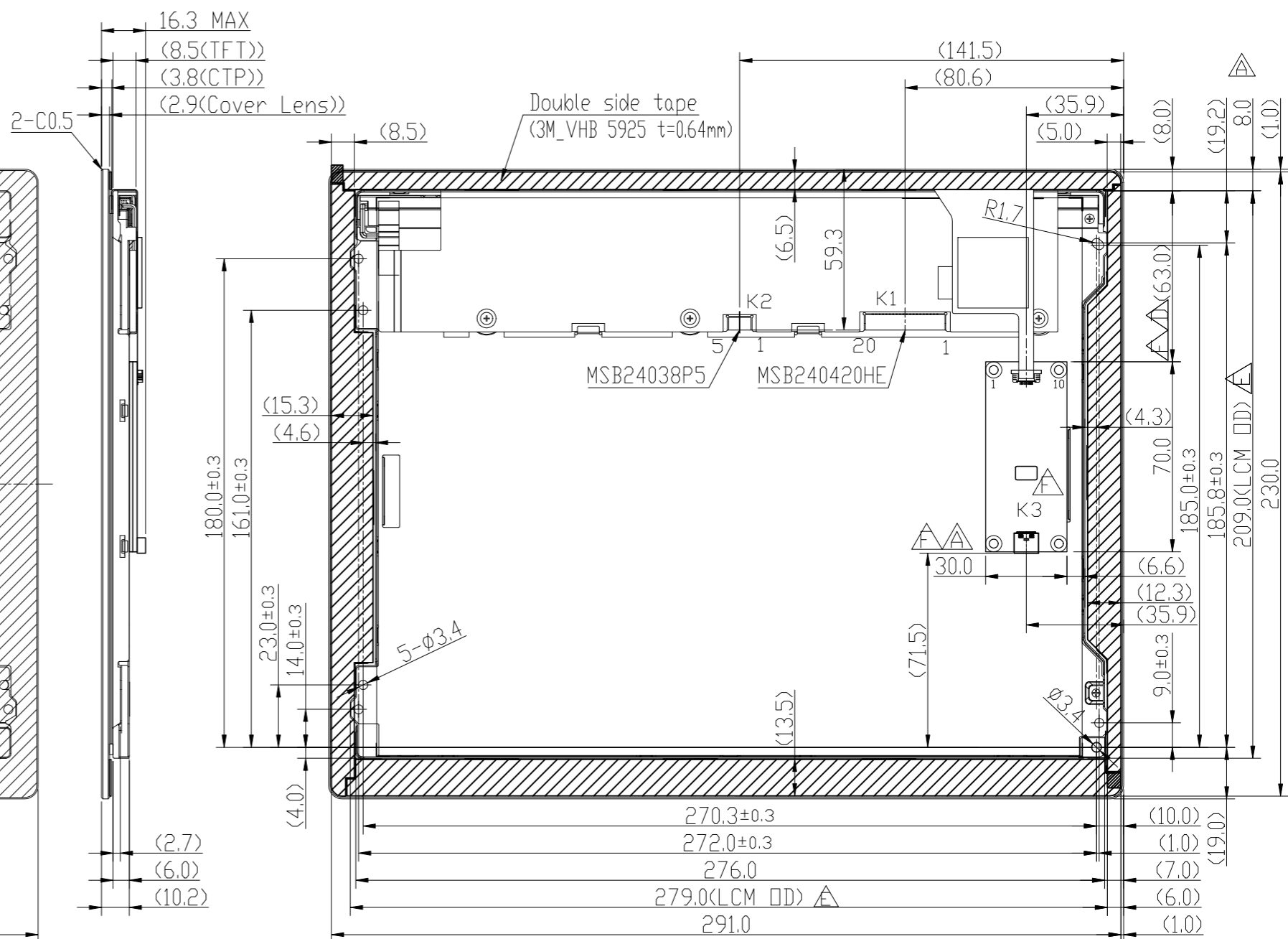
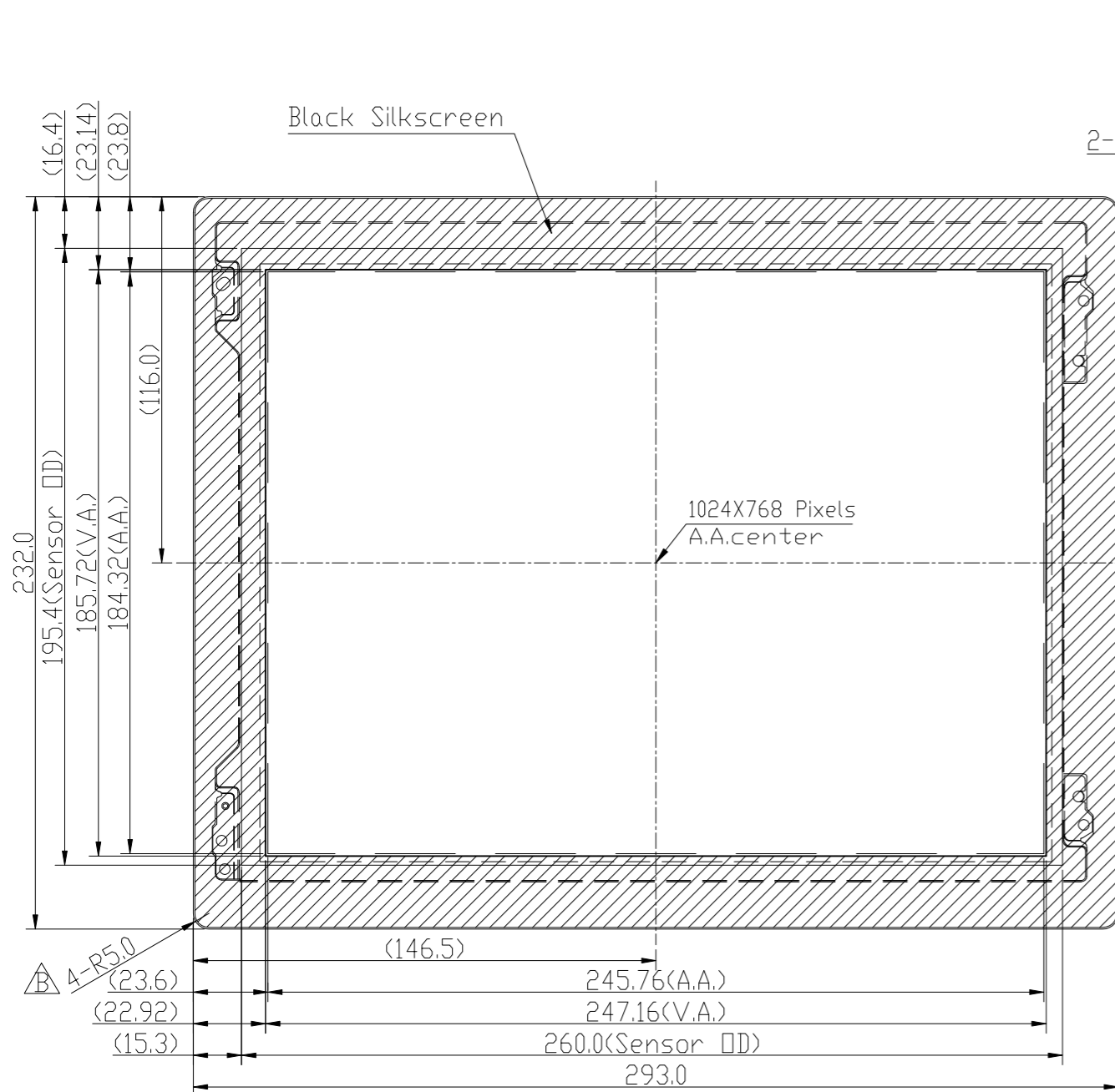

Figure 5

Warranty

This product has been manufactured to our company's specifications as a part for use in your company's general electronic products. It is guaranteed to perform according to delivery specifications. For any other use apart from general electronic equipment, we cannot take responsibility if the product is used in medical devices, nuclear power control equipment, aerospace equipment, fire and security systems, or any other applications in which there is a direct risk to human life and where extremely high levels of reliability are required. If the product is to be used in any of the above applications, we will need to enter into a separate product liability agreement.

- We cannot accept responsibility for any defect, which may arise from additional manufacturing of the product (including disassembly and reassembly), after product delivery.
- We cannot accept responsibility for any defect, which may arise after the application of strong external force to the product.
- We cannot accept responsibility for any defect, which may arise due to the application of static electricity after the product has passed our company's acceptance inspection procedures.
- When the product is in CCFL models, CCFL service life and brightness will vary according to the performance of the inverter used, leaks, etc. We cannot accept responsibility for product performance, reliability, or defect, which may arise.
- We cannot accept responsibility for intellectual property of a third part, which may arise through the application of our product to our assembly with exception to those issues relating directly to the structure or method of manufacturing of our product.



- Note:
- *1. LCD Display Type: TFT.Transmissive
 - *2. Pixel Arrangement: RGB-STRIPE
 - *3. Color Depth : 16.2M/262K Colors
 - *4. Interface : LVDS 18bit/24bit(VESA)
 - *5. Operating Voltage : 3.3V
 - *6. Backlight Supply : 12.0V TYP.
 - *7. Backlight : White LED
 - *8. Touch Panel Type : Capacitive touch panel
 - *9. Connector type :
 K1: STM-MSB240420HE or equivalent
 K2: STM-MSB24038P5 or equivalent
 K3: USB TYPE-C
 - *10. Operating Temperature : -20°C~70°C
 - *11. Storage Temperature : -30°C~80°C
 - *12. Unmarked Tolerace : ≤150,±0.3; >150,±0.5

K3 Terminal	
No	Pin Name
A1/B12	GND
A4/B9	VBUS
A5	NC
B8	NC
B7	D-
A6	D+
B6	D+
A7	D-
B5	NC
A8	NC
B4/A9	VBUS
A12/B1	GND

K2 Terminal	
No	Pin Name
1	NC
2	BLADJ
3	BLGN
4	BLGND
5	BLVCC

K1 Terminal			
No	Pin Name	No	Pin Name
1	VCC	11	RIN2-
2	VCC	12	RIN2+
3	GND	13	GND
4	FRC	14	CLKIN-
5	RIN0-	15	CLKIN+
6	RIN0+	16	GND
7	GND	17	RIN3-
8	RIN1-	18	RIN3+
9	RIN1+	19	DPS
10	GND	20	NC

F	Revise CTP And K3	liyongzheng 2023-10-19
E	Add sizes for LCM	yangwukun 2021-03-22
D	Change the Position of K3	yangwukun 2019-08-06
C	Revise & Adding Note	yangwukun 2019-05-16
B	Revise Cover Lens Corner 'R'	yangwukun 2019-03-29
A	Revise CTP And K3	yangwukun 2019-03-28
Rev Note		Date
Dwg Title		
LMT121DNGFWD-NNC Outline Dwg		
Dwg No. MK-006580f-1-1		Date 2019-03-21
Scale 1/2	Tol.	Unit mm
Paper Size A3		Checked Drawn yangwukun

TOPWAY