

MODEL NO : LMT084DNEFWD
MODEL VERSION: V0.1
SPEC VERSION : _____
ISSUED DATE: 2018-11-25

Preliminary Specification

Prepared by	Checked by	Approved by

Table of Contents

Table of Contents.....	2
1 General Specifications.....	3
2 Input/Output Terminals.....	4
3 Absolute Maximum Ratings	6
4 Electrical Characteristics	7
5 Timing Chart	9
6 Optical Characteristics.....	13
7 Environmental / Reliability Test	16

1 General Specifications

	Feature	Spec
Display Spec.	Size	8.4 inch
	Resolution	800(RGB) x 600
	Technology Type	a-Si TFT
	Pixel Configuration	R.G.B. Vertical Stripe
	Pixel pitch(mm)	0.213×0.213
	Display Mode	Transmissive, Normally white
	Surface Treatment	Anti-Glare
	Viewing Direction	12 o'clock
	Gray Scale Inversion Direction	6 o'clock
Mechanical Characteristics	LCM (W x H x D) (mm)	189.75x 149.4 x 4.8
	Active Area(mm)	170.4 (W) X127.8(H)
	With /Without TSP	Without TSP
	Matching Connection Type(CN1)	FH28-60S-0.5SH(Hirose)
	Matching Connection Type(CN2)	BHSR-02VS-1
	LED Numbers	27 LEDS
	Weight (g)	245
Electrical Characteristics	Interface	TTL(RGB 24bit)
	Color Depth	16.7M
	Driver IC	NT51008B*2+NT52002*1

Note 1: Viewing direction for best image quality is different from TFT definition. There is a 180 degree shift.

Note 2: Requirements on Environmental Protection: Q/S0002

Note 3: LCM weight tolerance: +/- 5%

2 Input/Output Terminals

2.1 CN1 of FPC

Matched Connector type: FH28-60S-0.5SH(Hirose)

Pin	Symbol	I/O	Description	Remark
1	GND	P	Ground	
2	NC	-	No connection	
3	VCC	P	Power supply	
4	R0	I	Red data Input(LSB)	
5	R1	I	Red data Input	
6	R2	I	Red data Input	
7	R3	I	Red data Input	
8	R4	I	Red data Input	
9	R5	I	Red data Input	
10	R6	I	Red data Input	
11	R7	I	Red data Input(MSB)	
12	G0	I	Green data Input(LSB)	
13	G1	I	Green data Input	
14	G2	I	Green data Input	
15	G3	I	Green data Input	
16	G4	I	Green data Input	
17	G5	I	Green data Input	
18	G6	I	Green data Input	
19	G7	I	Green data Input(MSB)	
20	B0	I	Blue data Input(LSB)	
21	B1	I	Blue data Input	
22	B2	I	Blue data Input	
23	B3	I	Blue data Input	
24	B4	I	Blue data Input	
25	B5	I	Blue data Input	
26	B6	I	Blue data Input	
27	B7	I	Blue data Input(MSB)	
28	DCLK	I	Clock input(Latch data at falling edge)	
29	DE	I	Data enable	
30	HSYNC	I	Horizontal sync input. Negative polarity	
31	VSYNC	I	Vertical sync input. Negative polarity	
32	MODE3	I	DE/SYNC mode select .normally pull high H:DE mode .L:HV mode	
33	RSTB	I	Global reset pin. RSTB= 0 ,module reset; RSTB= 1 normal operation	
34	STBYB	I	Standby mode, normally pull high STBYB="1",normal operation STBYB="0",source driver will turn off, all output are high-Z	
35	SHLR	I	Source right or left sequence control,normally pull high SHLR="L", shift left: last data=S1<-S2 S1200=first data ; SHLR="H", shift right :first data=S1->S2 S1200=last data	
36	VCC	P	Power supply	

37	UPDN	I	Gate up or down scan control. Normally pull low UPDN="L" , DOWN shift :G1->G2 ->G600 ; UPDN="H", up shift: G1<-G2 <-G600	
38	GND	P	Ground	
39	GND	P	Ground	
40	NC	-	No connection	
41	NC	-	No connection	
42	DITH	I	Dithering setting DITH="H" 6bit resolution (last 2 bits of input data truncated, default setting) DITH="L" 8bit resolution	
43	NC	-	No connection	
44	NC	-	No connection	
45	NC	-	No connection	
46	NC	-	No connection	
47	NC	-	No connection	
48	NC	-	No connection	
49	NC	-	No connection	
50	NC	-	No connection	
51	NC	-	No connection	
52	NC	-	No connection	
53	NC	-	No connection	
54	NC	-	No connection	
55	NC	-	No connection	
56	NC	-	No connection	
57	NC	-	No connection	
58	NC	-	No connection	
59	GND	P	Ground	
60	NC	-	No connection	

I---Input, O---Output, P--- Power/Ground, - ---No connection

Table 2.1 terminal pin assignments

2.2 CN2 pin assignment (Backlight interface)

Mating Connector: SBHT-002T-P0.5 or equivalent

Pin	Symbol	I/O	Description	Remark
1	LED+(Anode)	P	LED power supply (high voltage)	
2	LED-(Cathode)	P	LED power supply (low voltage)	

Table 2.2 Backlight terminal pin assignments

3 Absolute Maximum Ratings

GND=0V, Ta = 25°C

Item	Symbol	MIN	MAX	Unit	Remark
Power Voltage	VCC	-0.5	5.0	V	
Data Input voltage	V _{IN}	-0.5	5.0	V	Note1
Backlight forward current	I _{LED}	-	30	mA	For each LED
Operating Temperature	T _{op}	-20	70	°C	
Storage Temperature	T _{st}	-30	80	°C	
Relative Humidity (Note2)	RH	--	≤95	%	Ta ≤ 40°C
		--	≤85	%	40°C < Ta ≤ 50°C
		--	≤55	%	50°C < Ta ≤ 60°C
		--	≤36	%	60°C < Ta ≤ 70°C
		--	≤24	%	70°C < Ta ≤ 80°C
Absolute Humidity	AH	--	≤70	g/m	Ta > 70°C

Table 3.1 absolute maximum rating

Note1: Signals input include Rx,Gx,Bx,DCLK,DE,HSYNC,VSYNC,MODE3,RSTB,STBYB,SHLR,DITH.

Note2: Ta means the ambient temperature.

It is necessary to limit the relative humidity to the specified temperature range.
Condensation on the module is not allowed.

4 Electrical Characteristics

4.1 Recommended Operating Condition

VCC=3.3V GND=0V Ta = 25°C

Item	Symbol	Min	Typ	Max	Unit	Remark
Supply Voltage	VCC	3.0	3.3	3.6	V	
Input Signal Voltage	Low Level	V _{IL}	0	--	0.3xVCC	V
	High Level	V _{IH}	0.7xVCC	--	VCC	V
Output Signal Voltage	Low Level	V _{OL}	--	--	GND+0.4	V
	High Level	V _{OH}	VCC-0.4	--	--	V
(Panel+LSI) Power Consumption	Black Mode (60Hz)	--	660	--	mW	Note1
	Standby Mode	--	400	--	mW	

Table 4.1 LCD module electrical characteristics

Note1: To test the current dissipation, use "all Black Pattern".

4.2 Backlight Unit Driving Condition

LED_GND=GND=0V, Ta = 25°C

Item	Symbol	Min	Typ	Max	Unit	Remark
Channel1	I _F	-	180	225	mA	Note 1
Forward Voltage	V _F	9	9.6	10.8	V	
Backlight Power Consumption	W _{BL}	-	1728	-	mW	
Life Time	-	-	30,000	-	Hrs	Note 3

Table 4.2 LED backlight characteristics

Note 1: If LED is driven by high current, high ambient temperature & humidity condition. The life time of LED will be reduced. Operating life means brightness goes down to 50% initial brightness. Typical operating life time is an estimated data.

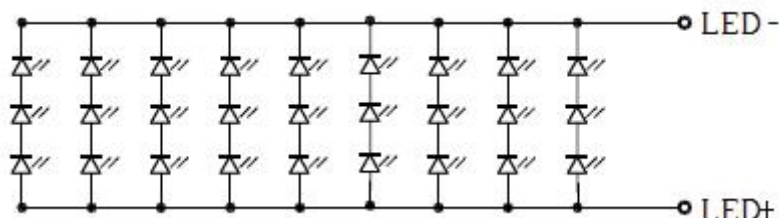
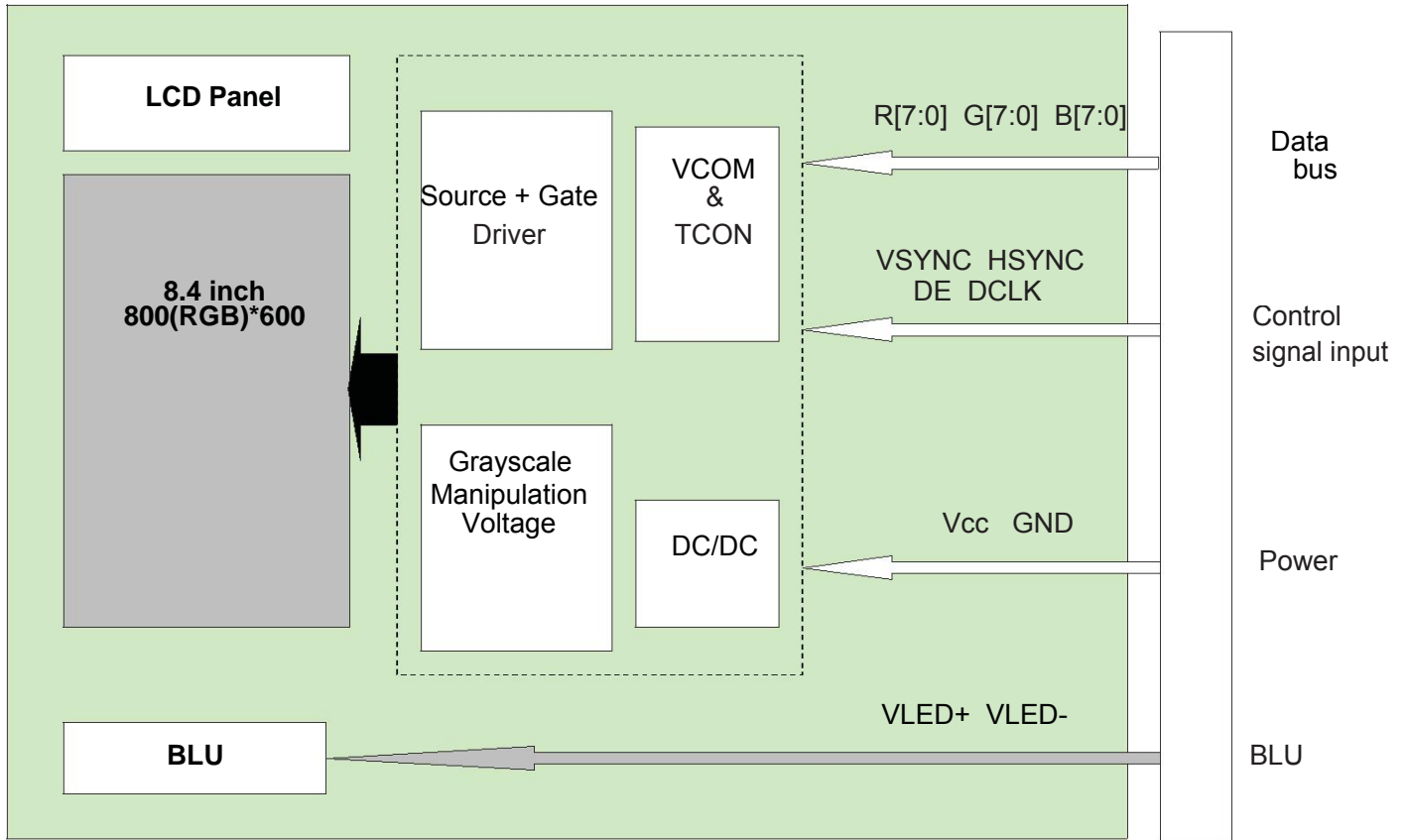

Figure4.2 LED connection of backlight

4.3 BLOCK DIAGRAM



5 Timing Chart

5.1.1 AC characteristics

VCC=3.3V, GND=0V, Ta=25°C

Parameter	Symbol	Min	Typ	Max	Unit	Remark
HSYNC Setup Time	T_{hst}	8	-	-	ns	
HSYNC Hold Time	T_{hhd}	8	-	-	ns	
VSYNC Setup Time	T_{vst}	8	-	-	ns	
VSYNC Hold Time	T_{vhd}	8	-	-	ns	
Data Setup Time	T_{dsu}	8	-	-	ns	
Data Hold Time	T_{dhd}	8	-	-	ns	
DE Setup Time	T_{esu}	8	-	-	ns	
DE Hold Time	T_{ehd}	8	-	-	ns	
CLKIN Cycle Time	T_{cph}	14	-	-	ns	
CLKIN Pulse Width	T_{cwh}	40	50	60	%	
Output stable time	T_{sst}	-	-	6	us	
VCC Power ON Slew rate	T_{por}	-	-	20	ms	From 0V to 90% VCC
RSTB pulse width	T_{rst}	50	-	-	us	DCLK = 65MHz

Table 5.1 AC characteristics

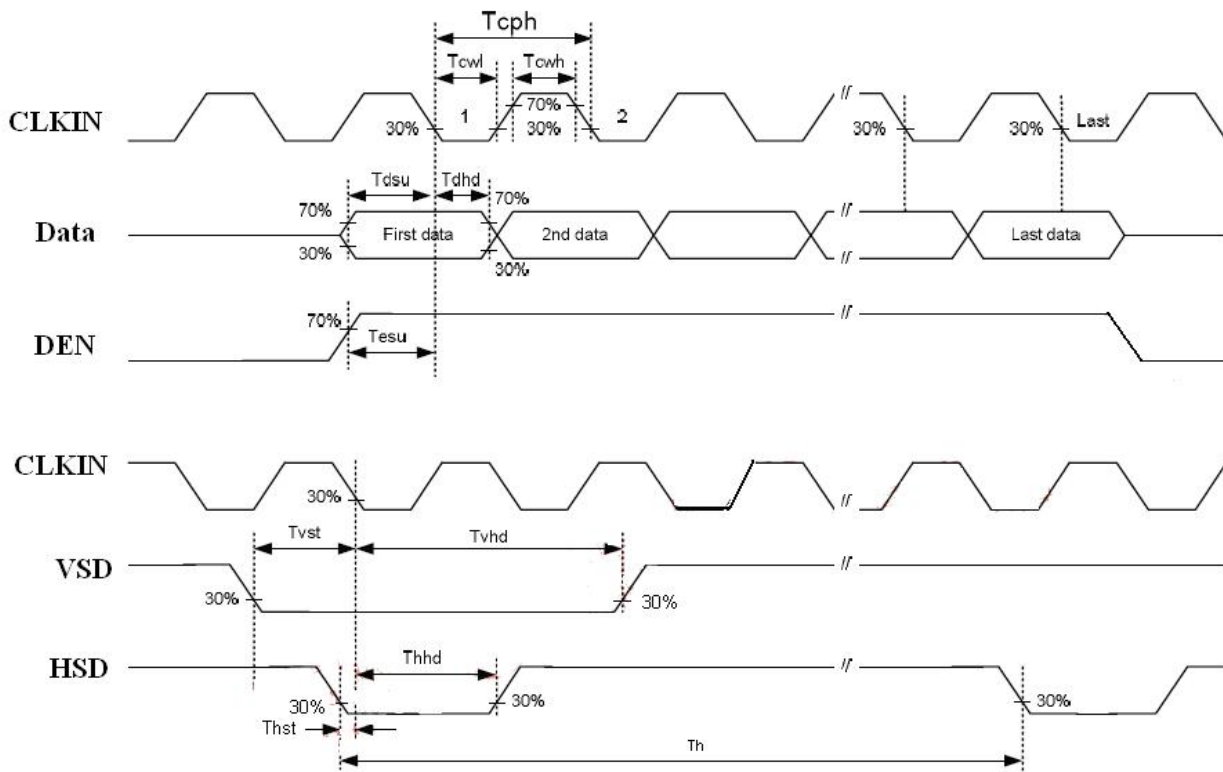

Figure 5.1 AC characteristics

5.2 Data input timing

5.2.1 Input timing at DE mode

VCC=3.3V, GND=0V, Ta=25°C

	Parameter	Symbol	Min.	Typ.	Max.	Unit	Remark
	Dclk frequency(Frame rate=60HZ)	Fclk	33	39.6	60	MHz	Tclk=1/Fclk
Horizontal section	Horizontal total	TH	890	1000	1300	Tclk	
	Horizontal blanking	THC	90	200	500	Tclk	Note1
	Valid Data Width	THD	-	800	-	Tclk	
Vertical section	Vertical total	TV	610	660	800	TH	
	Vertical blanking	TVC	10	60	200	TH	Note1
	Valid Data Width	TVD	-	600	-	TH	

Table 5.2.1 input timing (DE mode)

5.2.2 Input timing at HV mode

VCC=3.3V, GND=0V, Ta=25°C

	Parameter	Symbol	Min.	Typ.	Max.	Unit	Remark
	Dclk frequency(Frame rate=60HZ)	Fclk	35	39.6	50	MHz	Tclk=1/Fclk
Horizontal section	Horizontal pulse width	THPW	1	-	40	Tclk	
	Horizontal total	TH	900	1000	1200	Tclk	
	Horizontal back porch	THB	88	88	88	Tclk	
	Horizontal front porch	THFP	12	112	312	Tclk	
	Valid Data Width	THD	-	800	-	Tclk	
Vertical section	Vertical pulse width	TVPW	1	-	20	TH	
	Vertical total	TV	640	660	700	TH	
	Vertical back porch	TVB	39	39	39	TH	
	Vertical front porch	TVFP	1	21	61	TH	
	Valid Data Width	TVD	-	600	-	TH	

Table 5.2.2 input timing (HV mode)

Note1: $THC=THB+THFP$, $TVC=TVB+TVFP$, In HV mode, it is necessary to keep it in typical value.

5.3 Data input Timing Diagram

5.3.1 Vertical Input Timing Diagram

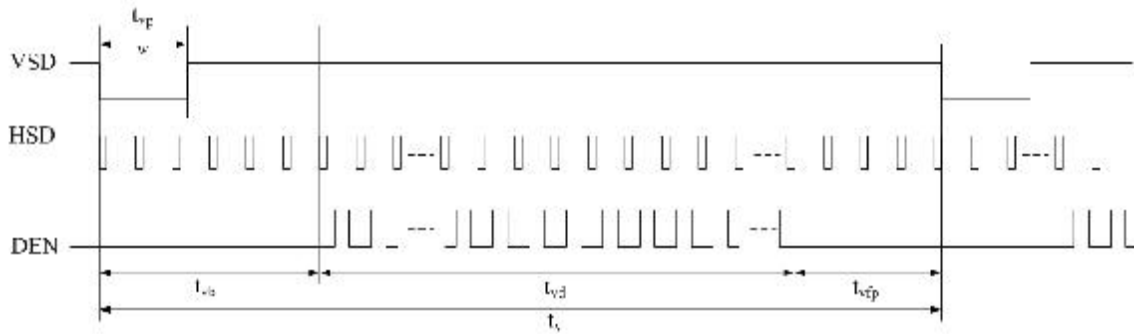

Figure 5.3.1 Vertical Input Timing Diagram

5.3.2 Horizontal Input Timing Diagram

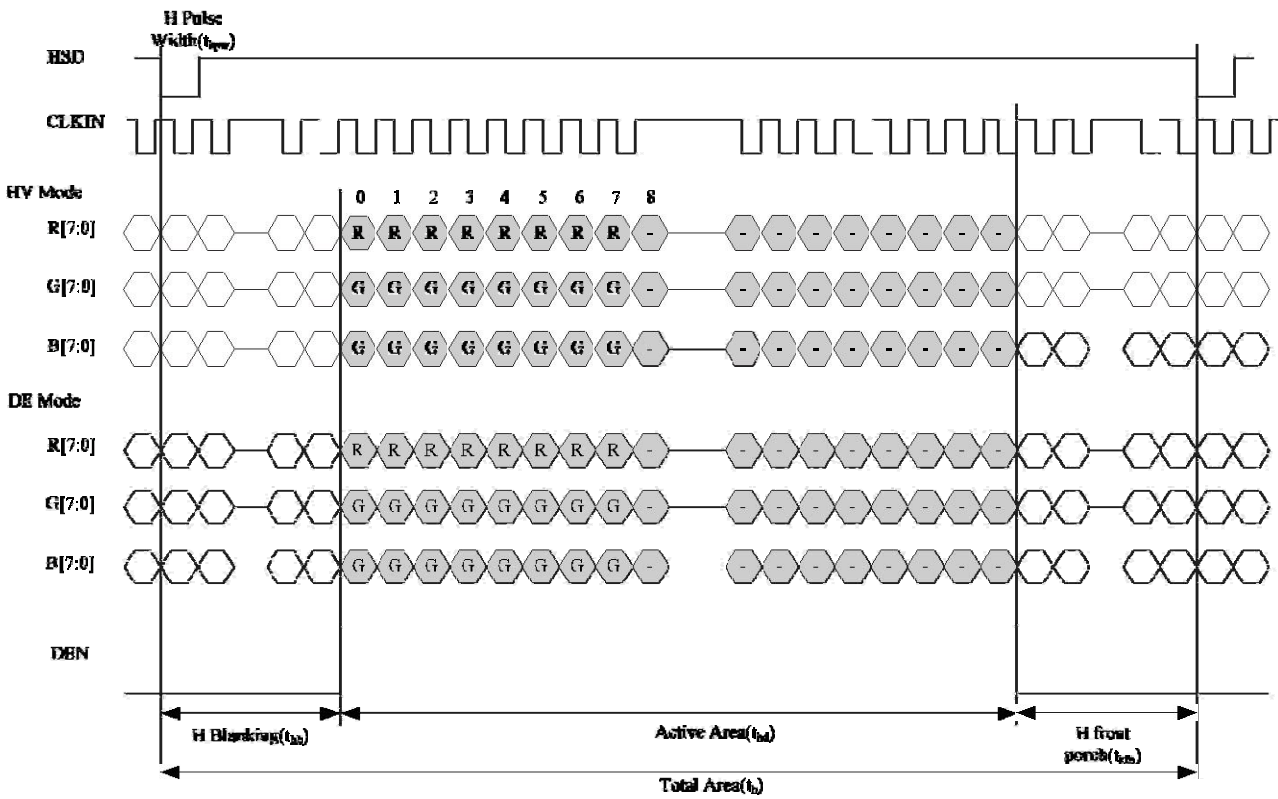

Figure 5.3.2 Horizontal Input Timing Diagram

5.4 POWER ON/OFF SEQUENCE

Item	Symbol	Min	Typ	Max	Unit	Remark
VCC 3.3V to signal starting	Tp1	5	-	50	ms	
VCC rising time	Tr	0.1	-	5	ms	Note1
Signal starting to backlight on	Tp2	150	-	-	ms	
Signal off to VCC 0V	Tp3	5	-	50	ms	
Backlight off to signal off	Tp4	150	-	-	ms	

Table 5.4 POWER ON/OFF SEQUENCE

Note1: Tr means the time of input voltage rise from 10% to 90%.

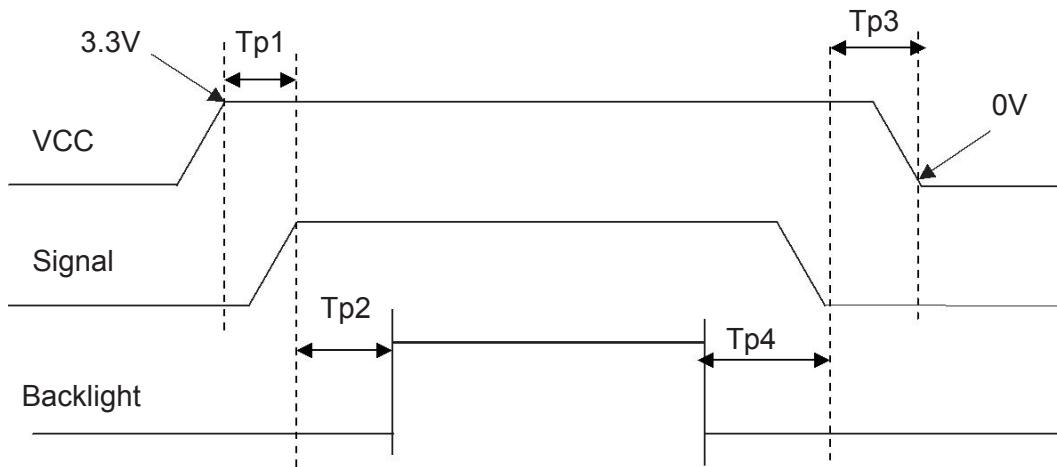

Figure5.4 Interface power on/off sequence

6 Optical Characteristics

Ta=25°C

Item	Symbol	Condition	Min	Typ	Max	Unit	Remark
View Angles	θT	CR 10	50	60	-	Degree	Note 2
	θB		60	70	-		
	θL		60	70	-		
	θR		60	70	-		
Contrast Ratio	CR	$\theta=0^\circ$	400	500	-		Note1 Note3
Response Time	T _{ON}	25	-	20	30	ms	Note1 Note4
	T _{OFF}						
Chromaticity	White	Backlight is on	x	0.260	0.310	0.360	Note1 Note5
			y	0.280	0.330	0.380	
	Red		x	0.551	0.601	0.651	
			y	0.281	0.331	0.381	
	Green		x	0.307	0.357	0.407	
			y	0.527	0.577	0.627	
	Blue		x	0.102	0.152	0.202	
			y	0.056	0.106	0.156	
Uniformity	U		70	75	-	%	Note1 Note6
NTSC			-	50	-	%	Note 5
Luminance Without TP	L		280	350	-	cd/m ²	Note1 Note7

Test Conditions:

1. I_F= 180 mA, V_F=10.5 V and the ambient temperature is 25±2 .humidity is 65±7%
2. The test systems refer to Note 1 and Note 2.

Note 1: Definition of optical measurement system.

The optical characteristics should be measured in dark room. After 5 Minutes operation, the optical properties are measured at the center point of the LCD screen. All input terminals LCD panel must be ground when measuring the center area of the panel.

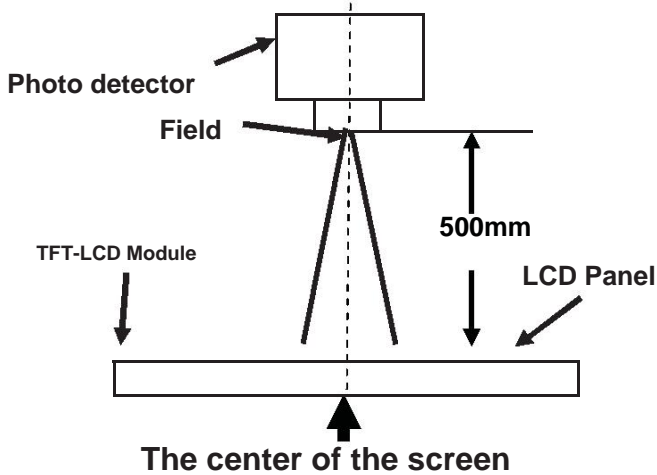

Item	Photo detector	Field
Contrast Ratio	SR-3A	1°
Luminance		
Chromaticity		
Lum Uniformity		
Response Time	BM-7A	2°

Note 2:

Definition of viewing angle range and measurement system.

viewing angle is measured at the center point of the LCD by CONOSCOPE(ergo-80)

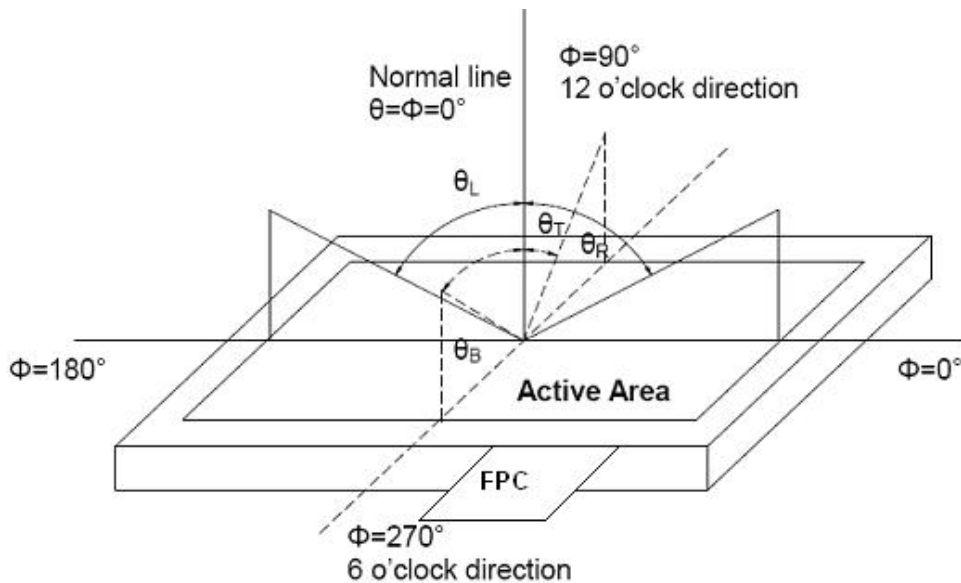

Note 3: Definition of contrast ratio

$$\text{Contrast ratio (CR)} = \frac{\text{Luminance measured when LCD is on the "White" state}}{\text{Luminance measured when LCD is on the "Black" state}}$$

“White state “: The state is that the LCD should drive by V_{white}.

“Black state”: The state is that the LCD should drive by V_{black}.

V_{white}: To be determined V_{black}: To be determined.

Note 4: Definition of Response time

The response time is defined as the LCD optical switching time interval between “White” state and “Black” state. Rise time (T_{ON}) is the time between photo detector output intensity changed from 90% to 10%. And fall time (T_{OFF}) is the time between photo detector output intensity changed from 10% to 90%.

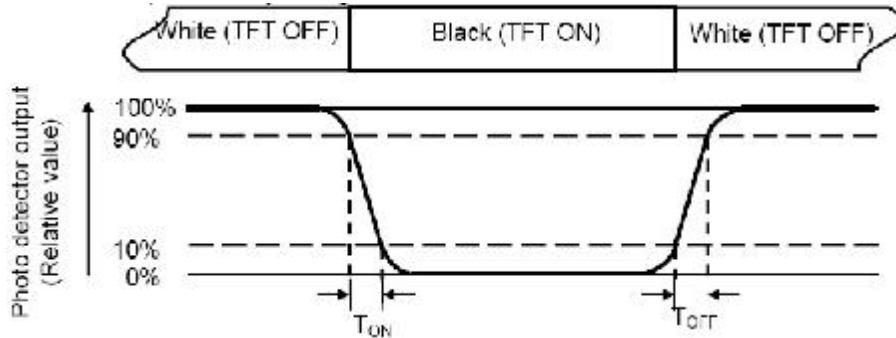

Note 5: Definition of color chromaticity (CIE1931)

Color coordinates measured at center point of LCD.

Note 6: Definition of Luminance Uniformity

Active area is divided into 9 measuring areas (Refer Fig. 2). Every measuring point is placed at the center of each measuring area.

$$\text{Luminance Uniformity (U)} = L_{\text{min}} / L_{\text{max}}$$

L-----Active area length W----- Active area width

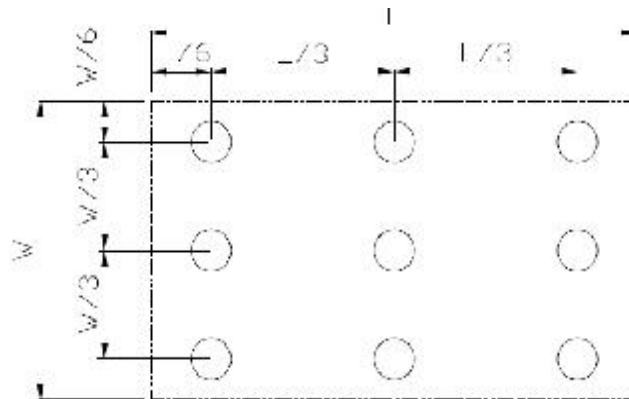

L_{max}: The measured Maximum luminance of all measurement position.

L_{min}: The measured Minimum luminance of all measurement position.

Note 7: Definition of Luminance:

Measure the luminance of white state at center point.

7 Environmental / Reliability Test

No	Test Item	Condition	Remarks
1	High Temperature Operation	Ts = +70℃ , 240 hours	IEC60068-2-1 GB2423.2
2	Low Temperature Operation	Ta = -20℃ , 240 hours	IEC60068-2-1 GB2423.1
3	High Temperature Storage	Ta = +80℃ , 240 hours	IEC60068-2-1 GB2423.2
4	Low Temperature Storage	Ta = -30℃ , 240 hours	IEC60068-2-1 GB2423.1
5	Storage at High Temperature and Humidity	Ta = +60℃ , 90% RH max,240hours	IEC60068-2-78 GB/T2423.3
6	Thermal Shock (non-operation)	-30℃ 30 min~+80℃ 30 min, Change time:5min, 100 Cycle	Start with cold temperature, End with high temperature, IEC60068-2-14,GB2423.22
7	ESD	C=150pF,R=330Ω,5point/panel Air:±8Kv,5times; Contact:±4Kv,5times (Environment:15℃ ~35℃ , 30%~60%.86Kpa~106Kpa)	IEC61000-4-2 GB/T17626.2
8	Vibration Test	Frequency range:10~55Hz Stroke:1.5mm Sweep:10Hz~55Hz~10Hz 2 hours for each direction of X.Y.Z. (6 hours for total)	IEC60068-2-6 GB/T2423.10
9	Mechanical Shock (Non Op)	Half Sine Wave 60G 6ms, ±X,±Y,±Z 3times for each direction	IEC60068-2-27 GB/T2423.5
10	Package Drop Test	Height:60cm, 1corner,3edges,6surfaces	IEC60068-2-32 GB/T2423.8

Note1: Ts is the temperature of panel's surface.

Note2: Ta is the ambient temperature of samples.

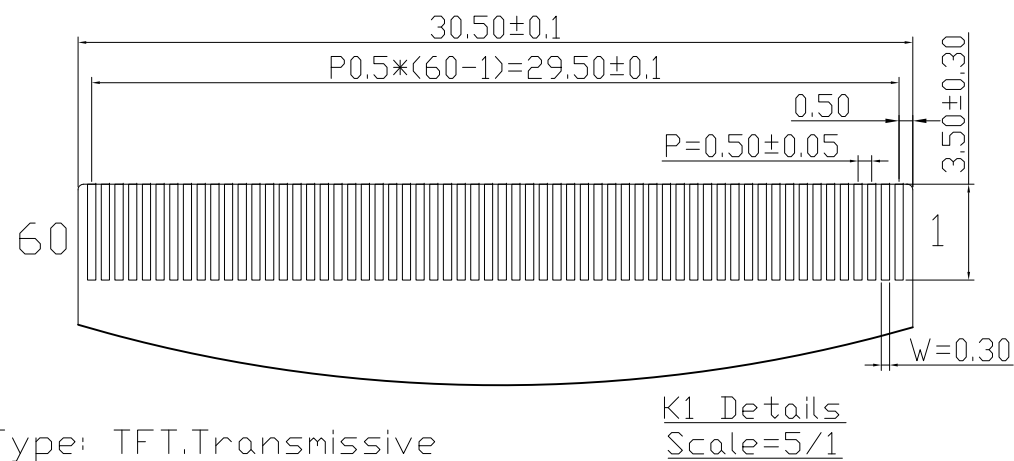
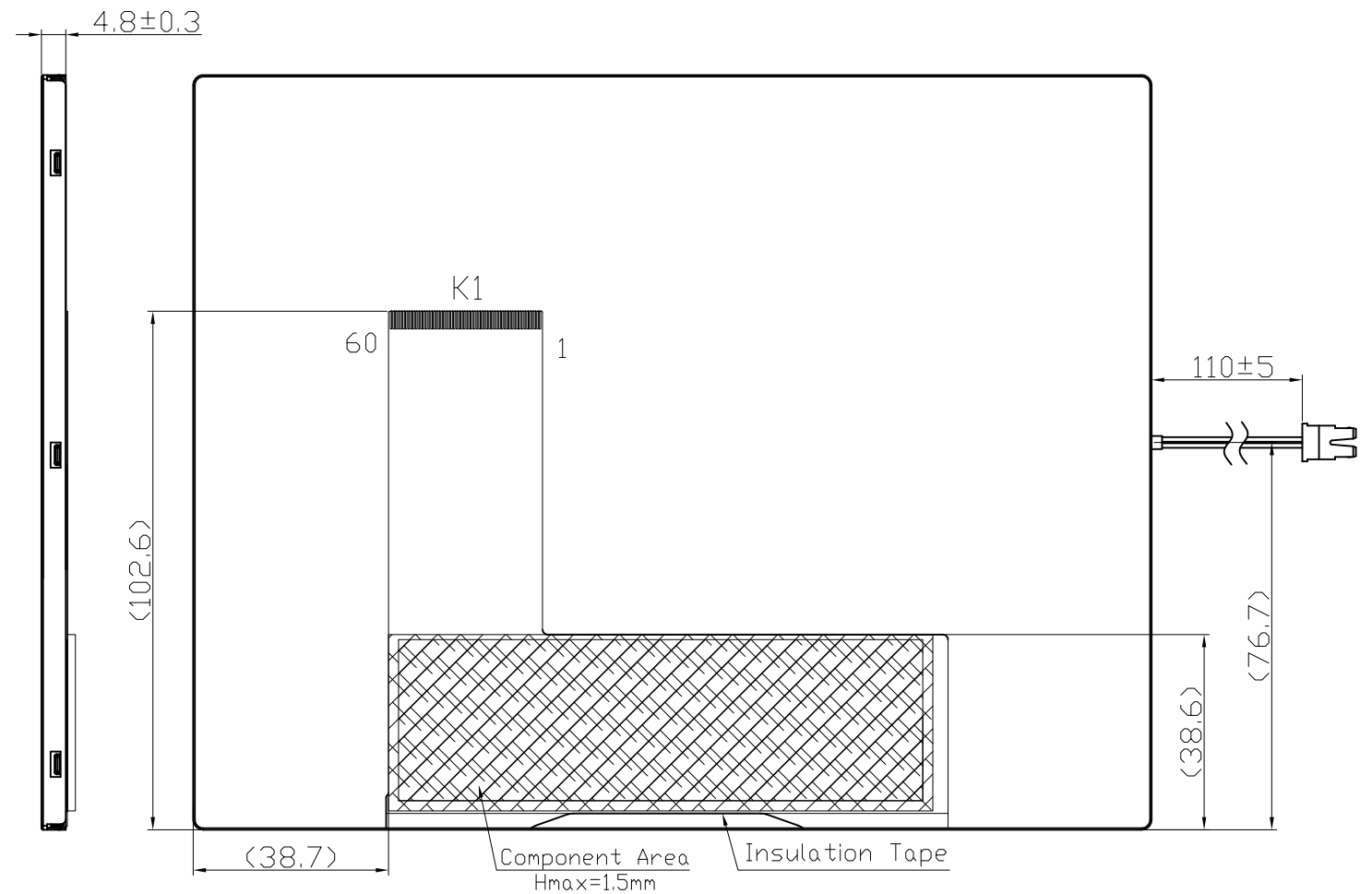
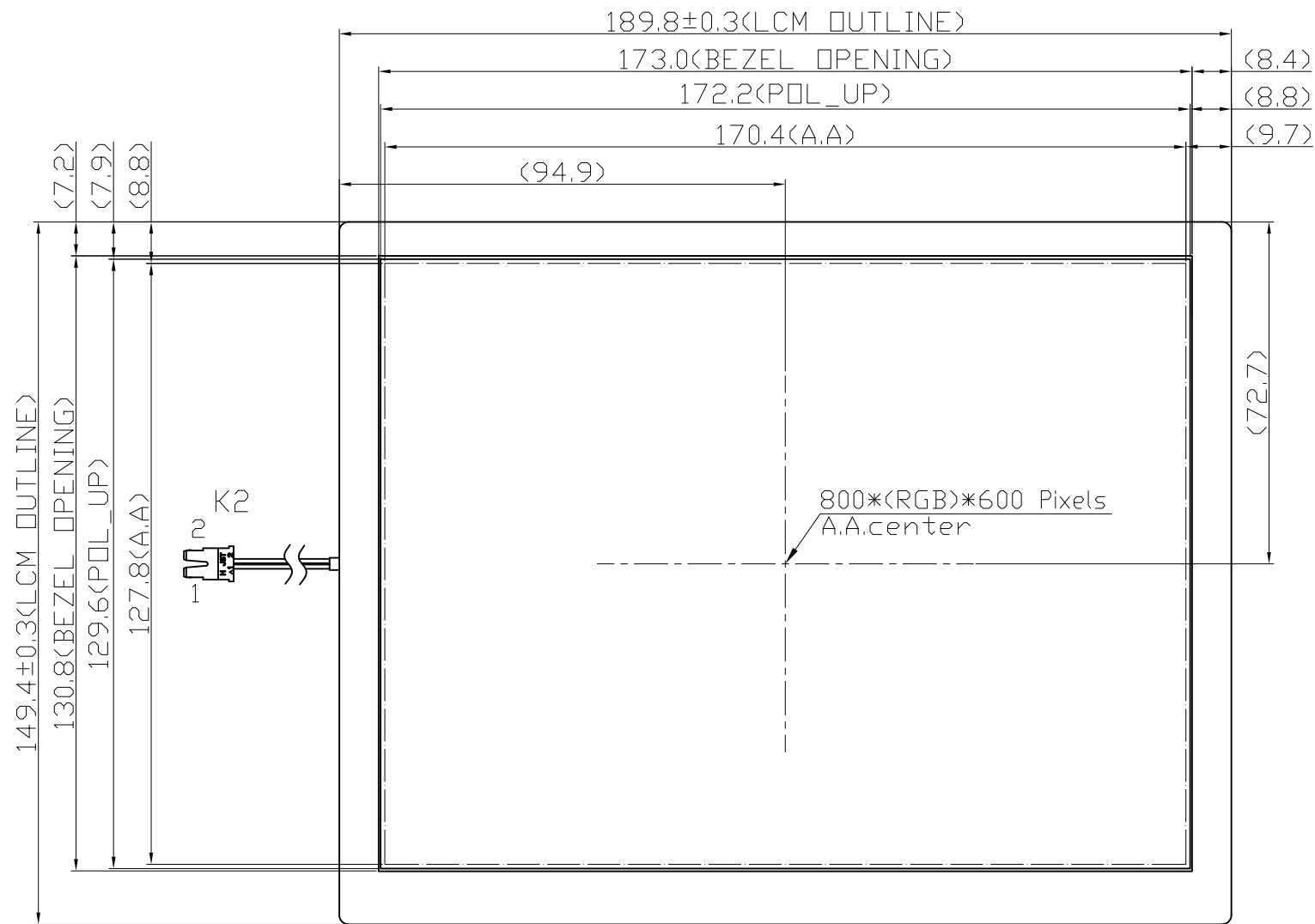

K1 Terminal					
No	Pin Name	No	Pin Name	No	Pin Name
1	GND	21	B1	41	NC
2	NC	22	B2	42	DITH
3	VCC	23	B3	43	NC
4	R0	24	B4	44	NC
5	R1	25	B5	45	NC
6	R2	26	B6	46	NC
7	R3	27	B7	47	NC
8	R4	28	DCLK	48	NC
9	R5	29	DE	49	NC
10	R6	30	HSD	50	NC
11	R7	31	VSD	51	NC
12	G0	32	MODE3	52	NC
13	G1	33	RSTB	53	NC
14	G2	34	STBYB	54	NC
15	G3	35	SHLR	55	NC
16	G4	36	VCC	56	NC
17	G5	37	UPDN	57	NC
18	G6	38	GND	58	NC
19	G7	39	GND	59	NC
20	B0	40	NC	60	NC

K2 Terminal	
No	Pin Name
1	RED+
2	BLACK-

- Note:
- *1. LCD Display Type: TFT, Transmissive
 - *2. Pixel Arrangement: RGB-STRIP
 - *3. Color Depth : 16.7M Colors
 - *4. Operating Voltage: 3.3V
 - *5. Backlight: White LED
 - *6. Interface: RGB_24bit
 - *7. Backlight Supply: 180mA (9.6 V TYP.)
 - *8. Terminal:
 - K1: 60Pin P0.5 FFC or Equivalent
 - K2: JST BHSR-02VS-1 or Equivalent
 - *9. Operating Temperature : -20°C~70°C
 - *10. Storage Temperature : -30°C~80°C
 - *11. General Tolerance : ±0.3;

C		
B		
A	Normalizing Drawing	yangwukun 2019-08-13
Rev	Note	Date
Dwg	Title	
	LMT084DNEFWD Outline Dwg	
Dwg No.	MK-006577a-1-1	Date 2019-02-22
Scale	Tol.	Unit mm
1/1		Paper Size A3
Approved	Checked	Drawn yangwukun

TOPWAY