



LM12896FCW-1

LCD Module User Manual

Prepared by: Li KeKe Date: 2020-07-09	Checked by: Date:	Approved by: Date:
---	----------------------------------	-----------------------------------

Rev.	Descriptions	Release Date
0.1	Prelimiay release	2020-07-09

Table of Content

1. Basic Specifications	3
1.1 Display Specifications	3
1.2 Mechanical Specifications	3
1.3 Block Diagram	3
1.4 Terminal Functions	4
1.5 Jumper Functions	4
2. Absolute Maximum Ratings	5
3. Electrical Characteristics	5
3.1 DC Characteristics	5
3.2 LED Backlight Circuit Characteristics	5
3.3 8080 Interface	6
3.4 6800 Interface	7
3.5 4-Line SPI MCU Interface	8
3.6 3-Line SPI MCU Interface	9
3.7 I2C MCU Interface	10
3.8 Reset Timing	10
4. Function Specifications	11
4.1 Adjusting the Display Contrast	11
4.2 Resetting the LCD module	11
4.3 Power off the LCD Module	11
4.4 Refreshing The LCD Module	11
4.5 Display Memory Map	11
4.6 Display Data RAM (DDRAM)	12
4.7 Instructions	13
Design and Handling Precaution	17

1. Basic Specifications

1.1 Display Specifications

- 1) LCD Display Mode : FSTN, Positive, Transflective
- 2) Display Color : Display Data = "1" : Dark Gray (*1)
: Display Data = "0" : Light Gray (*2)
- 3) Viewing Angle : 6 H
- 4) Driving Method : 1/96 duty, 1/10bias
- 5) Back Light : White LED backlight

Note:

*1. Color tone may slightly change by Temperature and Driving Condition.

*2. The Color is defined as the inactive / background color

*3. Fine Contrast adjustment function is necessary in application design for optimal display result

1.2 Mechanical Specifications

- 1) Outline Dimension : 63.8 x 47.8 x 9.8MAX
(see attached Outline Drawing for details)

1.3 Block Diagram

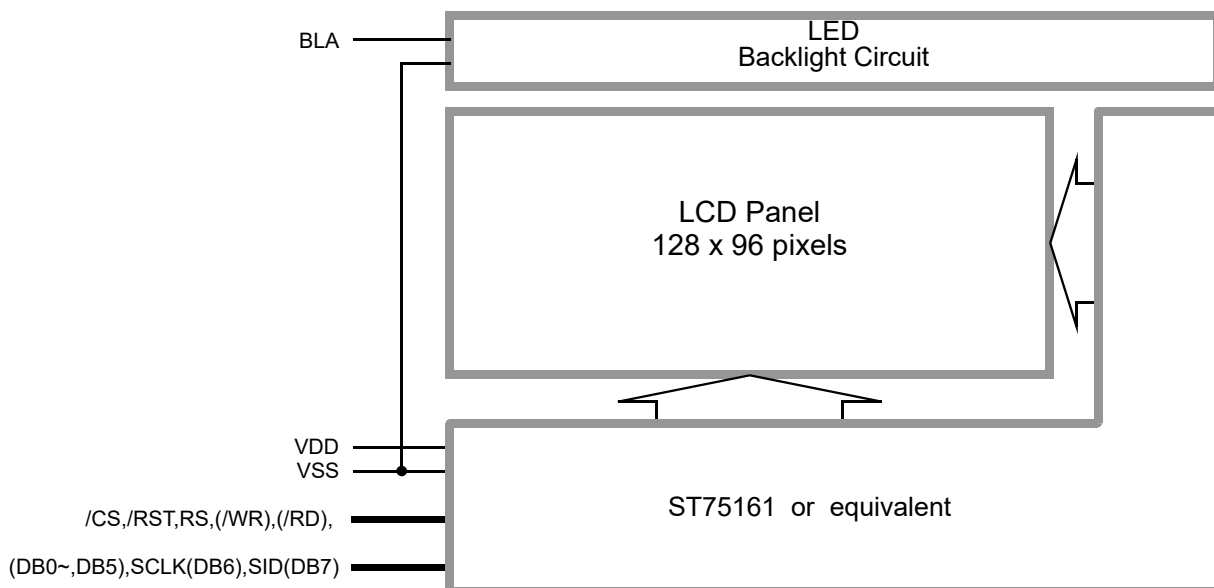

1.4 Terminal Functions

Pin No.		Pin Name	I/O	Descriptions						
K1,K2	K3			8-bit parallel 8080 mode	8-bit parallel 6800 mode	4-pin SPI(default)	3-pin SPI	I2C serial interface		
1	1	/CS	Input	Chip select input pin. /CS="L": This chip is selected and the MPU interface is active. /CS="H": This chip is not selected and the MPU interface is disabled(DB7~DB0] are high impedance).			Connect to VSS			
2	2	/RST	Input	Reset signal. /RST = L, internal Initialization is executed. /RST = H, Normal running.						
3	3	RS	Input	Register Select RS = H, Transferring the Display RAM data RS = L, Transferring the Instruction data		Connect to VDD				
4	-	NC(/WR)	Input	/WR=L→H, /RD=H; Data or Instruction latch into the LCD module	R/W = H, E=L; Data or Status read form the LCD module	Not used, leave open or pull Hi				
5	-	NC(/RD)	Input	/WR=H, /RD=L; Data or Status read form the LCD module	R/W=L, E= H→L; Data or Instruction latch into the LCD module					
6	-	NC(DB0)	I/O	8-bit Data bus; Three state I/O terminal for display data or instruction data When /CS=H, DB0~DB7= High Impedance					No connect, leave open.	
7	-	NC(DB1)	I/O							
8	-	NC(DB2)	I/O							
9	-	NC(DB3)	I/O							
10	-	NC(DB4)	I/O							
11	-	NC(DB5)	I/O							
12	4	SCLK(DB6)	I/O						serial input clock (SCL)	
13	5	SID(DB7)	I/O	SDA_IN, serial input data SDA_OUT, serial data and acknowledge output for the I2C interface.						
14	6	VDD	Power	Positive Power Supply						
15	7	VSS	Power	Negative Power Supply, Ground (0V)						
16	8	BLA	Power	Positive Power for LED backlight						

1.5 Jumper Functions

Jumper Setting		Function Descriptions
OPEN	COLSE	
JP1~JP10,JP13~JP15,JP18,JP20	JP11,JP12,JP16,JP17,JP19,JP21	Set to 8080 mode (8-bit parallel)-default
JP1~JP11,JP13,JP15,JP18,JP20	JP12,JP14,JP16,JP17,JP19,JP21	Set to 6800 interface mode (8-bit parallel)
JP10~JP13,JP19,JP21	JP1~JP9,JP14~JP18,JP20	Set to 4-pin SPI mode (serial)
JP11,JP12,JP16,JP19,JP21	JP1~JP10,JP13~JP15,JP17,JP18,JP20	Set to 3-pin SPI mode (serial)
JP12~JP14,JP19,JP21	JP1~JP11,JP15~JP18,JP20, C11 install 0R	Set I2C serial interface

2. Absolute Maximum Ratings

Items	Symbol	Min.	Max.	Unit	Condition
Supply Voltage	V_{DD}	-0.3	4.0	V	$V_{SS} = 0V$
Operating Temperature	T_{OP}	-40	70	°C	No Condensation
Storage Temperature	T_{ST}	-40	80	°C	No Condensation

Cautions:

Any Stresses exceeding the Absolute Maximum Ratings may cause substantial damage to the device. Functional operation of this device at other conditions beyond those listed in the specification is not implied and prolonged exposure to extreme conditions may affect device reliability.

3. Electrical Characteristics

3.1 DC Characteristics

$V_{SS} = 0V, V_{DD} = 3.3V, T_{OP} = 25^{\circ}C$

Items	Symbol	MIN.	TYP.	MAX.	Unit	Applicable Pin
Operating Voltage	V_{DD}	3.0	3.3	3.6	V	VDD
Input High Voltage	V_{IH}	$0.7V_{DD}$	-	V_{DD}	V	/CS, /RST, RS, /WR(R/W), /RD(E), DB4- DB7, DB0(SCLK), DB1~ DB3 (SID)
Input Low Voltage	V_{IL}	V_{SS}	-	$0.3V_{DD}$	V	
Output High Voltage	V_{OH}	$0.8V_{DD}$	-	V_{DD}	V	DB0-DB7
Output Low Voltage	V_{OL}	V_{SS}	-	$0.2V_{DD}$	V	
Operating Current	I_{DD}	-	0.89	3.13	mA	VDD

3.2 LED Backlight Circuit Characteristics

$V_{SS} = 0V, BLA = 3.3V, T_{OP} = 25^{\circ}C$

Items	Symbol	MIN.	TYP.	MAX.	Unit	Applicable Pin
Forward Voltage	BLA	-	3.3	-	V	BLA
Forward Current	I_{BLA}	-	48	60	mA	BLA

Cautions:

Exceeding the recommended driving current could cause substantial damage to the backlight and shorten its lifetime.

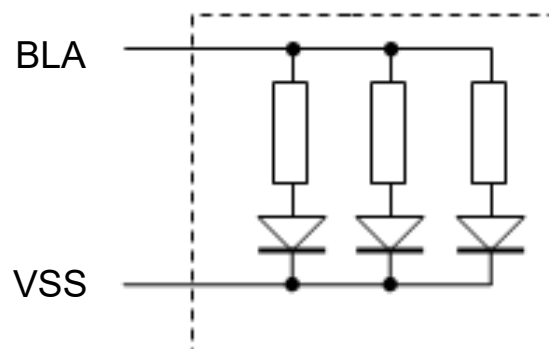

NO.of LEDs = 3 pcs

3.3 8080 Interface

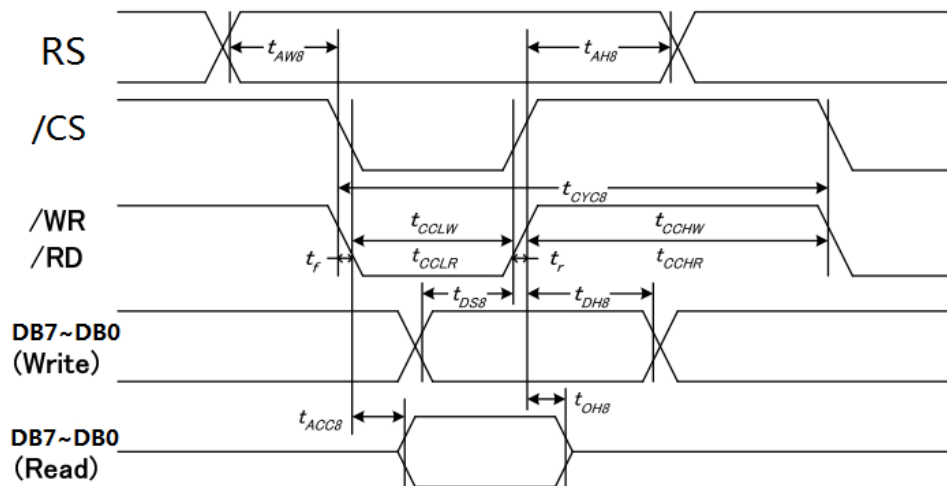

8080 Interface Timing Diagram

 $V_{SS} = 0V, V_{DD} = 3.3V, T_{OP} = 25^{\circ}C$

Item	Symbol	MIN.	TYP.	MAX.	Unit
Address Setup Time	t_{AW8}	26	-	-	ns
Address Hold Time	t_{AH8}	0	-	-	ns
System cycle time(WRITE)	t_{CYC8}	208	-	-	ns
/WR L pulse width(WRITE)	t_{CCLW}	91	-	-	ns
/WR H pulsewidth(WRITE)	t_{CCHW}	91	-	-	ns
System cycle time (READ)	t_{CYC8}	520	-	-	ns
/RD L pulse width (READ)	t_{CCLR}	234	-	-	ns
WRITE Data setup time	t_{CCHR}	234	-	-	ns
WRITE Data hold time	t_{DS8}	19.5	-	-	ns
Output Disable Time	t_{DH8}	19.5	-	-	ns
READ access time	t_{ACC8}	-	-	130	ns
READ Output disable time	t_{OH8}	13	-	77	ns

note: signal rise time and fall time should less than 15ns.

3.4 6800 Interface

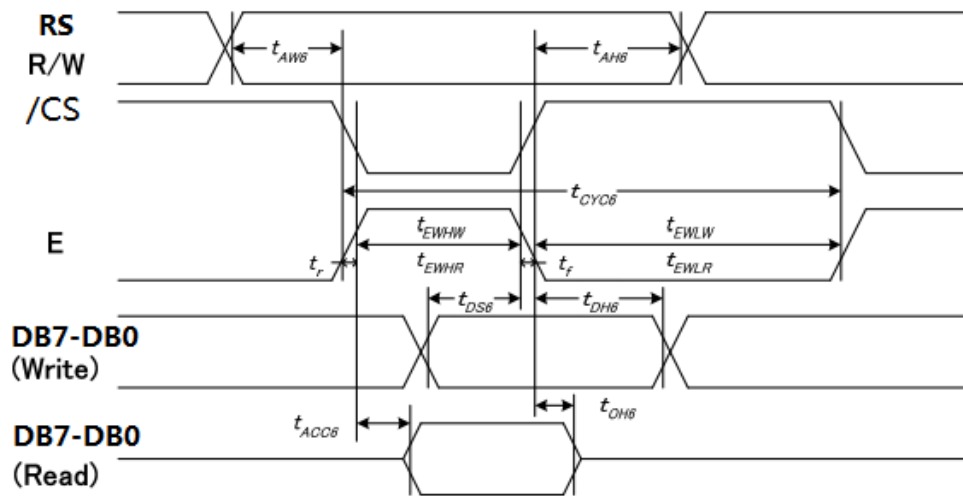

6800 Interface Timing Diagram

$V_{SS} = 0V, V_{DD} = 3.3V, T_{OP} = 25^{\circ}C$

Item	Symbol	MIN.	TYP.	MAX.	Unit
Address Setup Time	t_{AW6}	26	-	-	ns
Address Hold Time	t_{AH6}	0	-	-	ns
System cycle time(WRITE)	t_{CYC6}	208	-	-	ns
Enable L pulse width(WRITE)	t_{EHLW}	91	-	-	ns
Enable H pulse width(WRITE)	t_{EHWLW}	91	-	-	ns
System cycle time (READ)	t_{CYC6}	520	-	-	ns
Enable L pulse width (READ)	t_{EHLR}	234	-	-	ns
Enable H pulse width (READ)	t_{EHWHR}	234	-	-	ns
Write data setup time	t_{DS6}	19.5	-	-	ns
Write data hold time	t_{DH6}	19.5	-	-	ns
Read data access time	t_{ACC6}	-	-	130	ns
Read data output disable time	t_{OH6}	13	-	77	ns

note: signal rise time and fall time should less than 15ns.

3.5 4-Line SPI MCU Interface

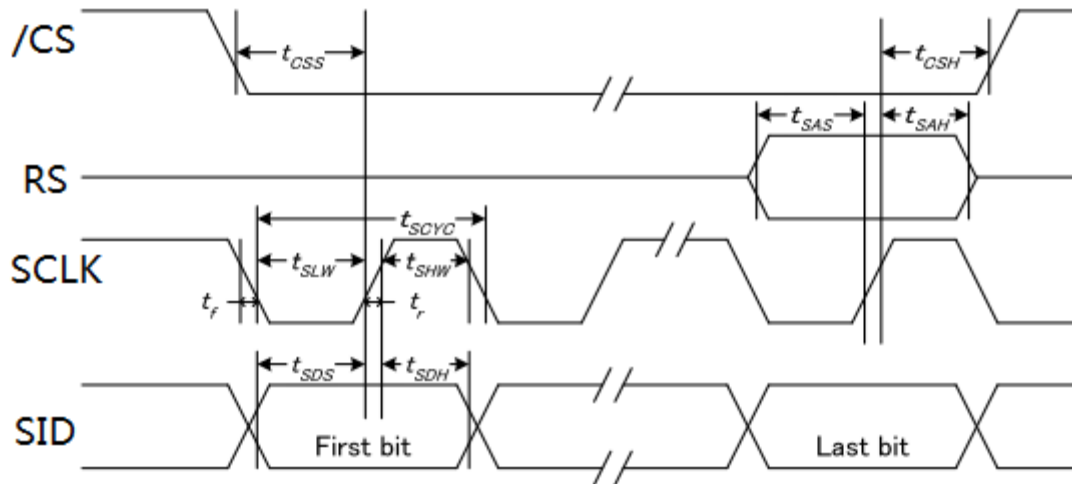

4-Line SPI Interface Timing Diagram

$V_{SS} = 0V, V_{DD} = 3.3V, T_{OP} = 25^{\circ}C$

Item	Symbol	MIN.	TYP.	MAX.	Unit
Serial clock period	tSCYC	104	-	-	ns
SCL "H" pulse width	tSHW	39	-	-	ns
SCL "L" pulse width	tSLW	39	-	-	ns
Address setup time	tSAS	26	-	-	ns
Address hold time	tSAH	26	-	-	ns
Data setup time	tSDS	26	-	-	ns
Data hold time	tSDH	26	-	-	ns
CSB-SCLK time	tCSS	26	-	-	ns
CSB-SCLK time	tCSH	26	-	-	ns
CS "H" pulse width	tCHW	0	-	-	ns

note: signal rise time and fall time should less than 15ns

3.6 3-Line SPI MCU Interface

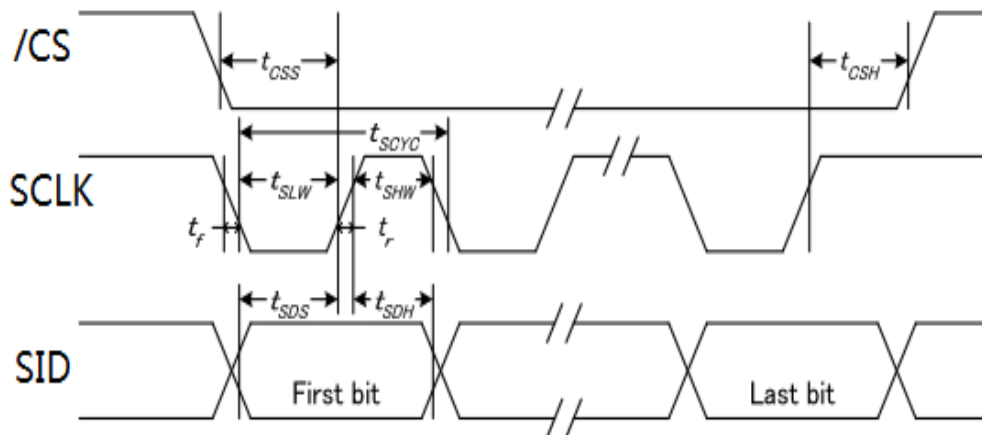

3-Line SPI Interface Timing Diagram

$V_{SS} = 0V, V_{DD} = 3.3V, T_{OP} = 25^{\circ}C$

Item	Symbol	MIN.	TYP.	MAX.	Unit
Serial clock period	tSCYC	104	-	-	ns
SCL "H" pulse width	tSHW	39	-	-	ns
SCL "L" pulse width	tSLW	39	-	-	ns
Data setup time	tSDS	26	-	-	ns
Data hold time	tSDH	26	-	-	ns
CSB-SCL time	tCSS	26	-	-	ns
CSB-SCL time	tCSH	26	-	-	ns

note: signal rise time and fall time should less than 15ns

3.7 I2C MCU Interface

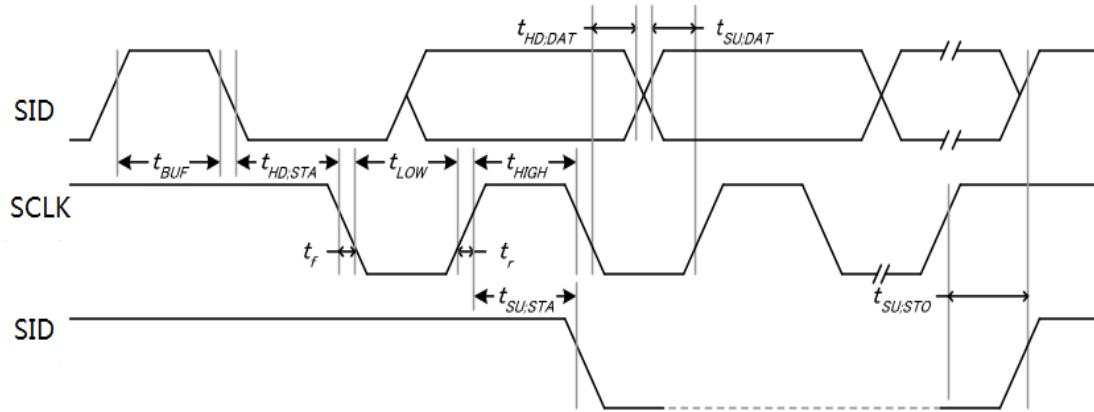

I2C Interface Timing Diagram

$V_{SS} = 0V, V_{DD} = 3.3V, T_{OP} = 25^{\circ}C$

Item	Symbol	MIN.	TYP.	MAX.	Unit
SCL clock frequency	fSCL	-	-	400	KHZ
SCL clock low period	tLOW	1.69	-	-	us
SCL clock high period	tHIGH	0.78	-	-	us
Data set-up time	tSU;Data	1.3	-	-	us
Data hold time	tHD;Data	0	-	0.63	us
Setup time for a repeated START condition	tSU;STA	0.78	-	-	us
Start condition hold time	tHD;STA	0.78	-	-	us
Setup time for STOP condition	tSU;STO	0.78	-	-	us
Bus free time between a STOP and START	tBUF	1.3	-	-	us
Signal rise time	tr	26+0.1Cb	-	210	ns
Signal fall time	tf	26+0.1Cb	-	210	ns
Capacitive load represented by each bus line	Cb	-	-	400	pF
Tolerable spike width on bus	tSW	-	-	35	ns

note: signal rise time and fall time should less than 15ns

3.8 Reset Timing

$V_{SS}=0V, V_{DD} =3.3V, T_{OP} =25^{\circ}C$

Item	Symbol	MIN.	TYP.	MAX.	Unit
Reset time	tR	-	-	1-	ms
Reset "L" pulse width	tRW	1	-	-	ms

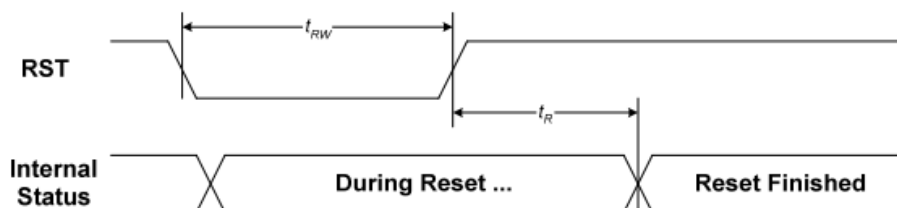

Reset Timing Diagram

4. Function Specifications

4.1 Adjusting the Display Contrast

- This LCD module equipped with latest digital contrast adjustment function.
- Its display contrast could be adjusted by MCU command. (Please see the command tables for details)

- It is recommended to provide a contrast adjustment interface for end-user, where the best display result could meet the individual preference in mass production.

4.2 Resetting the LCD module

The LCD module should be initialized by setting /RST terminal at low level after the power supply stable.

4.3 Power off the LCD Module

It recommends that LCD module should enter sleep mode before power off.

4.4 Refreshing The LCD Module

It recommends that the operating modes and display contents should be refreshed periodically to prevent the effect of unexpected noise.

4.5 Display Memory Map

Page Address	Data	LCD Module Top View						
0	D7 ⋮ D0							
1	D7 ⋮ D0							
:	:							
5	D7 ⋮ D0							
:	:							
8	D7 ⋮ D0							
:	:							
11	D7 ⋮ D0							
Column Address		00h	→					7F
Internal Display RAM Address								

Note: Display start line = 0, INV = 0.

4.6 Display Data RAM (DDRAM)

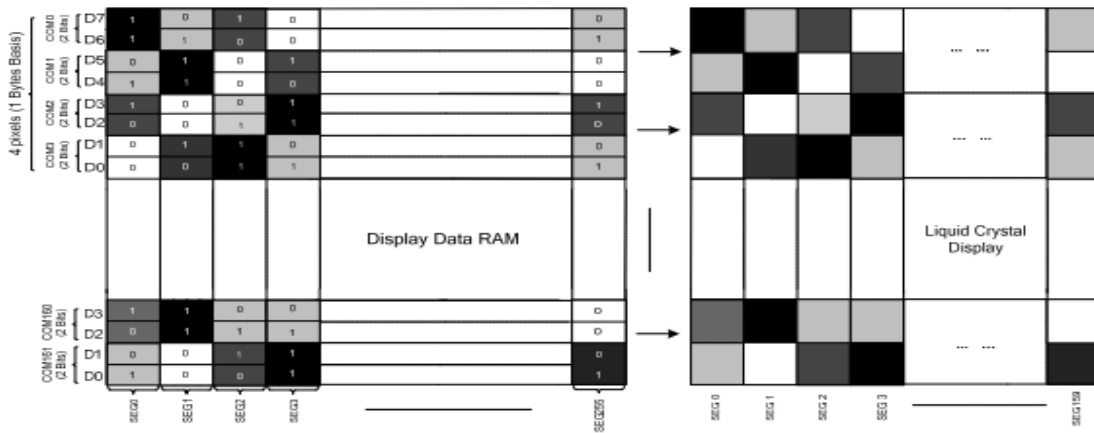

2 Bits Data N=0~3		DDRAM		LCD
D2N+1	D2N			
1	1	1	1	Black
0	0	0	0	White
1	0	1	0	Dark Gray
0	1	0	1	Light Gray

DDRAM Mapping (4-Level Gray Scale Mode)

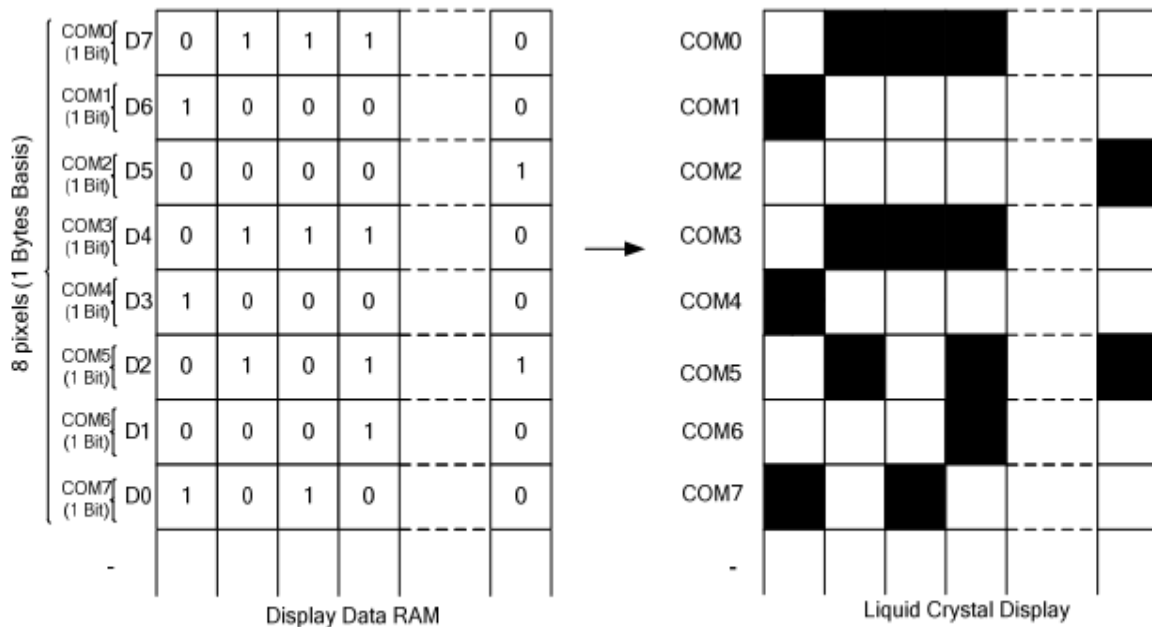

DDRAM Mapping (Monochrome Mode)

4.7 Instructions

INSTRUCTION	A0	R/W	COMMAND BYTE								DESCRIPTION
			D7	D6	D5	D4	D3	D2	D1	D0	
1.Extension Command	0	0	0	0	1	1	EXT1	0	0	EXT0	Set extension instruction
Ext[1:0]=0,0 (Extension Command 1)											
2.Display ON/OFF	0	0	1	0	1	0	1	1	1	DSP	Set LCD display DSP=0: Display off DSP=1: Display on
3.Inverse Display	0	0	1	0	1	0	0	1	1	INV	Set inverse display INV=0: Normal display INV=1: Inverse display
4.All Pixel ON/OFF	0	0	0	0	1	0	0	0	1	AP	Set all pixel on mode AP=0: All pixel off mode AP=1: All pixel on mode
5.Display Control	0	0	1	1	0	0	1	0	1	0	Set display control CLD :Set CL dividing ratio DT[7:0] : Set the number of duty LF[4:0] : Set N-line inversion counter FI : Set the inversion type of frame at the end of common scan cycle
	1	0	0	0	0	0	0	CLD	0	0	
	1	0	DT7	DT6	DT5	DT4	DT3	DT2	DT1	DT0	
	1	0	0	0	LF4	FI	LF3	LF2	LF1	LF0	
6.Power Save	0	0	1	0	0	1	0	1	0	SLP	Set power save mode SLP=0: Sleep out mode SLP=1: Sleep in mode
7.Set Page Address	0	0	0	1	1	1	0	1	0	1	Set page address Starting page address: 00h ≤ YS ≤ 27h Ending page address: YS ≤ YE ≤ 27h
	1	0	YS7	YS6	YS5	YS4	YS3	YS2	YS1	YS0	
	1	0	YE7	YE6	YE5	YE4	YE3	YE2	YE1	YE0	
8.Set Column Address	0	0	0	0	0	1	0	1	0	1	Set column address Starting column address: 00h ≤ XS ≤ 9Fh Ending column address: XS ≤ XE ≤ 9Fh
	1	0	XS7	XS6	XS5	XS4	XS3	XS2	XS1	XS0	
	1	0	XE7	XE6	XE5	XE4	XE3	XE2	XE1	XE0	
9.Data Scan Direction	0	0	1	0	1	1	1	1	0	0	Set normal/ inverse display of address and address scan direction
	1	0	0	0	0	0	0	MV	MX	0	
10.Write Data	0	0	0	1	0	1	1	1	0	0	Write data to DDRAM
	1	0	D7	D6	D5	D4	D3	D2	D1	D0	
11.Read Data	0	0	0	1	0	1	1	1	0	1	Read data from DDRAM (Only for parallel interface and I ² C)
	1	1	D7	D6	D5	D4	D3	D2	D1	D0	
12.Partial In	0	0	1	0	1	0	1	0	0	0	Set partial area Starting partial display address: 00h ≤ PTS ≤ 9Fh Ending partial display address: 00h ≤ PTE ≤ 9Fh
	1	0	PTS7	PTS6	PTS5	PTS4	PTS3	PTS2	PTS1	PTS0	
	1	0	PTE7	PTE6	PTE5	PTE4	PTE3	PTE2	PTE1	PTE0	

INSTRUCTION	A0	R/W	COMMAND BYTE								DESCRIPTION
			D7	D6	D5	D4	D3	D2	D1	D0	
13.Partial Out	0	0	1	0	1	0	1	0	0	1	Exit the partial mode
14.Read/Modify/Write In	0	0	1	1	1	0	0	0	0	0	Enable read modify write
15.Read/Modify/Write Out	0	0	1	1	1	0	1	1	1	0	Disable read modify write
16.Scroll Area	0	0	1	0	1	0	1	0	1	0	Set scroll area TL[7:0] : Set top line address BL[7:0] : Set bottom line address NSL[7:0] : Number of specified line SCM[1:0] : Area scroll mode
	1	0	TL7	TL6	TL5	TL4	TL3	TL2	TL1	TL0	
	1	0	BL7	BL6	BL5	BL4	BL3	BL2	BL1	BL0	
	1	0	NSL7	NSL6	NSL5	NSL4	NSL3	NSL2	NSL1	NSL0	
17.Set Start Line	0	0	1	0	1	0	1	0	1	1	Set scroll start address $00h \leq SL \leq 9Fh$
	1	0	SL7	SL6	SL5	SL4	SL3	SL2	SL1	SL0	
18.OSC ON	0	0	1	1	0	1	0	0	0	1	Turn on the internal oscillator
19.OSC OFF	0	0	1	1	0	1	0	0	1	0	Turn off the internal oscillator
20.Power Control	0	0	0	0	1	0	0	0	0	0	Power circuit operation VB=0: OFF, VB=1: ON VF=0: OFF, VF=1: ON VR=0: OFF, VR=1: ON
	1	0	0	0	0	0	VB	0	VF	VR	
21.Set Vop	0	0	1	0	0	0	0	0	0	1	Set Vop
	1	0	0	0	Vop5	Vop4	Vop3	Vop2	Vop1	Vop0	
	1	0	0	0	0	0	0	Vop8	Vop7	Vop6	
22.Vop Control	0	0	1	1	0	1	0	1	1	VOL	Control Vop VOL=0: Vop increase one step VOL=1: Vop decrease one step
23.Read Register Mode	0	0	0	1	1	1	1	1	0	REG	Set read register mode REG=0: read the register value of Vop[5:0] REG=1: read the register value of Vop[8:6]
24.Nop	0	0	0	0	1	0	0	1	0	1	No operation
25.Read Status (Parallel and I ² C)	0	1	D7	D6	D5	D4	D3	D2	D1	D0	Read status byte (Parallel and I ² C)
26.Read Status (4-Line and 3-Line SPI)	0	0	1	1	1	1	1	1	1	0	Read status byte (4-Line and 3-Line SPI)
	0	1	D7	D6	D5	D4	D3	D2	D1	D0	
27.Data Format Select	0	0	0	0	0	0	1	DO	0	0	DO=0: LSB on bottom (Default) DO=1: LSB on top
28. Display Mode	0	0	1	1	1	1	0	0	0	0	Set display mode DM=0 : Mono(Default) DM=1 : 4Gray Scale Mode
	1	0	0	0	0	1	0	0	0	DM	

INSTRUCTION	A0	R/W	COMMAND BYTE								DESCRIPTION
			D7	D6	D5	D4	D3	D2	D1	D0	
29.Set ICON	0	0	0	1	1	1	0	1	1	ICON	Enable/Disable ICON RAM ICON=1 : Enable ICON RAM ICON=0 : Disable ICON RAM
Ext[1:0]=0,1 (Extension Command 2)											
30. Set Gray Level	0	0	0	0	1	0	0	0	0	0	Set gray scale level GL[4:0]: Set Light Gray Level GD[4:0]: Set Dark Gray Level
	1	0	0	0	0	0	0	0	0	0	
	1	0	0	0	0	0	0	0	0	0	
	1	0	0	0	0	0	0	0	0	0	
	1	0	0	0	0	GL4	GL3	GL2	GL1	GL0	
	1	0	0	0	0	GL4	GL3	GL2	GL1	GL0	
	1	0	0	0	0	GL4	GL3	GL2	GL1	GL0	
	1	0	0	0	0	0	0	0	0	0	
	1	0	0	0	0	0	0	0	0	0	
	1	0	0	0	0	GD4	GD3	GD2	GD1	GD0	
	1	0	0	0	0	GD4	GD3	GD2	GD1	GD0	
	1	0	0	0	0	GD4	GD3	GD2	GD1	GD0	
	1	0	0	0	0	GD4	GD3	GD2	GD1	GD0	
	1	0	0	0	0	GD4	GD3	GD2	GD1	GD0	
	1	0	0	0	0	0	0	0	0	0	
	1	0	0	0	0	0	0	0	0	0	
31.Analog Circuit Set	0	0	0	0	1	1	0	0	1	0	Set analog circuit BE[1:0]: Booster efficiency set BS[2:0]: Set bias ratio
	1	0	0	0	0	0	0	0	0	0	
	1	0	0	0	0	0	0	0	BE1	BE0	
	1	0	0	0	0	0	0	0	BS2	BS1 BS0	
32.Booster Level	0	0	0	1	0	1	0	0	0	1	Set booster level BST=0 : X8 BST=1 : X10
	1	0	1	1	1	1	1	0	1	BST	
33. Driving Select	0	0	0	1	0	0	0	0	0	DS	Power type DS=0: Internal (Default) DS=1 :External
34.Auto Read Control	0	0	1	1	0	1	0	1	1	1	Set auto-read instruction XARD=0: Enable auto read XARD=1: Disable auto read
	1	0	1	0	0	XARD	1	1	1	1	
35.OTP WR/RD Control	0	0	1	1	1	0	0	0	0	0	OTP WR/RD control WR/RD=0: Enable OTP read WR/RD=1: Enable OTP write
	1	0	0	0	WR/RD	0	0	0	0	0	
36.OTP Control Out	0	0	1	1	1	0	0	0	0	1	OTP control out
37.OTP Write	0	0	1	1	1	0	0	0	1	0	OTP write
38.OTP Read	0	0	1	1	1	0	0	0	1	1	OTP read

INSTRUCTION	A0	R/W	COMMAND BYTE								DESCRIPTION
			D7	D6	D5	D4	D3	D2	D1	D0	
39.OTP Selection Control	0	0	1	1	1	0	0	1	0	0	OTP selection control Ctrl=1: Disable OTP Selection Ctrl=0: Enable OTP Selection
	1	0	1	Ctrl	0	1	1	0	0	1	
40.OTP Programming Setting	0	0	1	1	1	0	0	1	0	1	OTP programming setting
	1	0	0	0	0	0	0	1	1	1	
41.Frame Rate	0	0	1	1	1	1	0	0	0	0	Frame rate setting in different temperature range
	1	0	0	0	0	FRA4	FRA3	FRA2	FRA1	FRA0	
	1	0	0	0	0	FRB4	FRB3	FRB2	FRB1	FRB0	
	1	0	0	0	0	FRC4	FRC3	FRC2	FRC1	FRC0	
	1	0	0	0	0	FRD4	FRD3	FRD2	FRD1	FRD0	
42.Temperature Range	0	0	1	1	1	1	0	0	1	0	Temperature range setting
	1	0	0	TA6	TA5	TA4	TA3	TA2	TA1	TA0	
	1	0	0	TB6	TB5	TB4	TB3	TB2	TB1	TB0	
	1	0	0	TC6	TC5	TC4	TC3	TC2	TC1	TC0	
43.Temperature Gradient Compensation	0	0	1	1	1	1	0	1	0	0	Set temperature gradient compensation coefficient
	1	0	MT13	MT12	MT11	MT10	MT03	MT02	MT01	MT00	
	1	0	MT33	MT32	MT31	MT30	MT23	MT22	MT21	MT20	
	1	0	MT53	MT52	MT51	MT50	MT43	MT42	MT41	MT40	
	1	0	MT73	MT72	MT71	MT70	MT63	MT62	MT61	MT60	
	1	0	MT93	MT92	MT91	MT90	MT83	MT82	MT81	MT80	
	1	0	MTB3	MTB2	MTB1	MTB0	MTA3	MTA2	MTA1	MTA0	
	1	0	MTD3	MTD2	MTD1	MTD0	MTC3	MTC2	MTC1	MTC0	
	1	0	MTF3	MTF2	MTF1	MTF0	MTE3	MTE2	MTE1	MTE0	
Ext[1:0]=1,1(Extension Command 4)											
44.Enable OTP	0	0	1	1	0	1	0	1	1	0	Enable OTP EOTP =0 ; Disable (Default) EOTP =1 ; Enable
	1	0	0	0	0	EOTP	0	0	0	0	

Note: *1. Do not use any other command not listed, or the system malfunction may result.
 *2. For the details of the Display Commands, please refer to ST75161 data sheet.

Design and Handling Precaution

1. The LCD panel is made by glass. Any mechanical shock (eg. dropping from high place) will damage the LCD module.
2. Do not add excessive force on the surface of the display, which may cause the Display color change abnormally.
3. The polarizer on the LCD is easily get scratched. If possible, do not remove the LCD protective film until the last step of installation.
4. Never attempt to disassemble or rework the LCD module.
5. Only Clean the LCD with Isopropyl Alcohol or Ethyl Alcohol. Other solvents (eg. water) may damage the LCD.
6. When mounting the LCD module, make sure that it is free from twisting, warping and distortion.
7. Ensure to provide enough space (with cushion) between case and LCD panel to prevent external force adding on it, or it may cause damage to the LCD or degrade the display result.
8. Only hold the LCD module by its side. Never hold LCD module by add force on the heat seal or TAB.
9. Never add force to component of the LCD module. It may cause invisible damage or degrade of the reliability.
10. LCD module could be easily damaged by static electricity. Be careful to maintain an optimum anti-static work environment to protect the LCD module.
11. When peeling off the protective film from LCD, static charge may cause abnormal display pattern. It is normal and will resume to normal in a short while.
12. Take care and prevent get hurt by the LCD panel sharp edge.
13. Never operate the LCD module exceed the absolute maximum ratings.
14. Keep the signal line as short as possible to prevent noisy signal applying to LCD module.
15. Never apply signal to the LCD module without power supply.
16. IC chip (eg. TAB or COG) is sensitive to the light. Strong lighting environment could possibly cause malfunction. Light sealing structure casing is recommend.
17. LCD module reliability may be reduced by temperature shock.
18. When storing the LCD module, avoid exposure to the direct sunlight, high humidity, high temperature or low temperature. They may damage or degrade the LCD module