



深圳市拓普微科技开发有限公司

SHENZHEN TOPWAY TECHNOLOGY CO., LTD.

LM6020FCW-2

LCD Module User Manual

Prepared by: Li KeKe Date: 2020-11-26	Checked by: Date:	Approved by: Date:
---	----------------------------------	-----------------------------------

Rev.	Descriptions	Release Date
0.1	New release	2020-11-26

Table of Content

1. Basic Specifications.....	3
1.1 Display Specifications.....	3
1.2 Mechanical Specifications.....	3
1.3 Block Diagram.....	3
1.4 Terminal Functions.....	4
2. Absolute Maximum Ratings.....	5
3. Electrical Characteristics.....	5
3.1 DC Characteristics.....	5
3.2 LED Backlight Circuit Characteristics.....	5
3.3 AC Characteristics.....	6
4. Function specifications.....	10
4.1 Application circuit(Example).....	10
4.2 Adjusting the Display Contrast.....	10
4.3 Basic Setting.....	10
4.4 Resetting the LCD module.....	10
4.5 Display Memory Map.....	11
4.6 Display Commands.....	12
5. Design and Handling Precaution.....	14

1. Basic Specifications

1.1 Display Specifications

- 1) LCD Display Mode : FSTN, Positive, Transflective
- 2) Display Color : Display Data = "1" : Dark Gray(*1)
: Display Data = "0" : Light Gray (*2)
- 3) Viewing Angle : 6H
- 4) Driving Method : 1/65 duty, 1/10 bias
- 5) Backlight : White LED backlight

Note:

*1. Color tone may slightly change by Temperature and Driving Condition.

*2. The Color is defined as the inactive / background color

*3. Fine Contrast adjustment function is necessary in the application design for optimal display result

1.2 Mechanical Specifications

- 1) Outline Dimension : 44.9x 32.6 x 8.9MAX (mm)
(See attached Outline Drawing for details)

1.3 Block Diagram

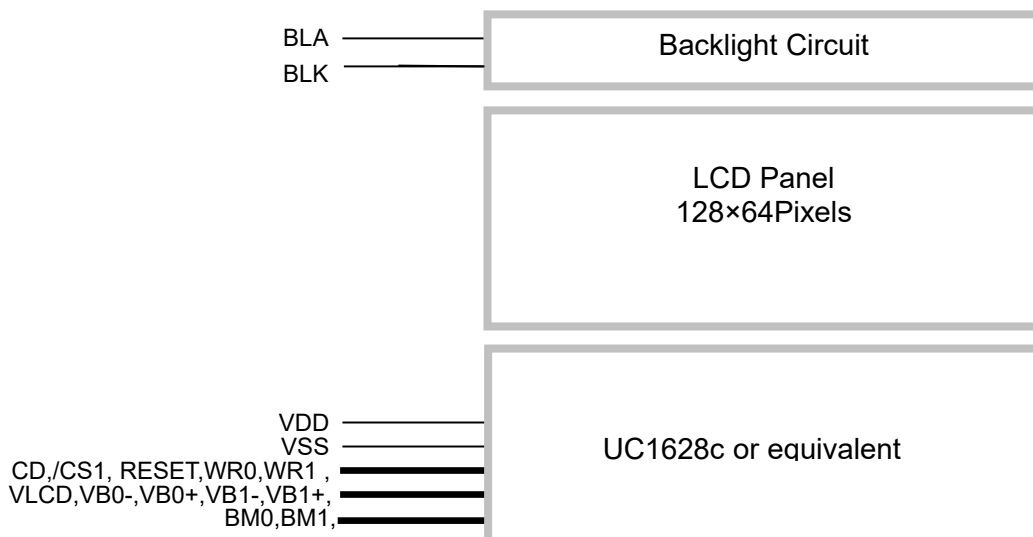

1.4 Terminal Functions

Pin No.	PIN Name	I/O	Descriptions			
			8080 mode (default)	6800 mode	4-SPI mode	I2C mode
1	/CS1	I	Chip Select /CS=L, enable access to the LCD module /CS=H, disable access to the LCD module			Not used, connect to VSS
2	RESET	I	Reset signal /RES = L, Initialization is executed /RES = H, Normal running.			
3	CD	I	Register Select D/C = H, Transferring the Display Data D/C = L, Transferring the Control Data			Not used, connect to VSS
4	WR0	I	WR0=L→H, WR1=H; Data or Instruction latch into the LCD module	WR0=H,WR1=H; Data or Status read from the LCD module WR0=L,WR1=H→L;	Not used, connect to VSS	Not used, connect to VSS
5	WR1	I	WR0=L→H, WR1=H; Data or Instruction latch into the LCD module	WR0=H,WR1=H; Data or Status read from the LCD module WR0=L,WR1=H→L;	Not used, connect to VSS	Not used, connect to VSS
6	D0	I/O	8-bit Data bus; Three state I/O terminal for display data or instruction data when /CS=H, D0~D7=High Impedance.		In serial modes, connect D[0] to SCK, D[3] to SDAI for write and D[5:4] to SDAO for read. SDAI and SDAO may be connected together if necessary. Connect unused pins to VSS.	
:	:					
13	D7					
14	VDD	P	Positive power supply			
15	VSS	P	Negative power supply,0V			
16,17	NC	-	-			
18	VB0-	P	LCD Bias Voltages. These are the voltage sources to provide SEG driving currents.			
19	VB0+					
20	VB1-					
21	VB1+					
22~27	NC	-	-			
28	VLCD	P	High voltage LCD Power Supply			
29	NC	-	-			
30	BM0	I	Bus mode;The interface bus mode is determined by BM[1:0]:			
31	BM1		Mode		BM[1;0]	
			8080(8-bit)		10	
			6800(8-bit)		11	
		4-wire SPI w/ 8-bit token (S8)		01		
		2-wire SPI(I ² C)		00		
32	NC	-	-			

2. Absolute Maximum Ratings

Items	Symbol	Min.	Max.	Unit	Condition
Supply Voltage	V_{DD}	-0.3	+4.0	V	$V_{SS} = 0V$
Input Voltage	V_{IN}	-0.3	+4.0	V	$V_{SS} = 0V$
Operating Temperature	T_{OP}	-40	+70	°C	No Condensation
Storage Temperature	T_{ST}	-40	+80	°C	No Condensation

Cautions:

Any Stresses exceeding the Absolute Maximum Ratings may cause substantial damage to the device. Functional operation of this device at other conditions beyond those listed in the specification is not implied and prolonged exposure to extreme conditions may affect device reliability.

3. Electrical Characteristics

3.1 DC Characteristics

$V_{SS}=0V, V_{DD}=3.3V, T_{OP}=25^{\circ}C$

Items	Symbol	MIN.	TYP.	MAX.	Unit	Condition / Application Pin
Operating Voltage	V_{DD}	3.0	3.3	3.6	V	VDD
Input High Voltage	V_{IH}	$0.8 \times V_{DD}$	-	V_{DD}	V	REST, /CS1, D0~D7, CD, WR0, W R1, BM0, BM1
Input Low Voltage	V_{IL}	V_{SS}	-	$0.2 \times V_{DD}$	V	
Operating Current	I_{DD}	-	0.4	1.45	mA	VDD

3.2 LED Backlight Circuit Characteristics

$V_{SS}=0V, BLA=3.3V, T_{OP} = 25^{\circ}C$

Items	Symbol	MIN.	TYP.	MAX.	Unit	Applicable Pin
Forward Voltage	V_{BLA}	-	3.3	-	V	BLA
Forward Current	I_{BLA}	-	34	40	mA	BLA

Cautions:

Exceeding the recommended driving current could cause substantial damage to the backlight and shorten its lifetime.

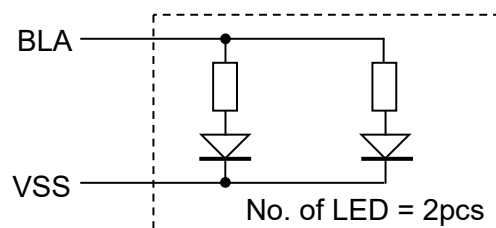

3.3 AC Characteristics

3.3.1 8080 Mode System Bus Timing

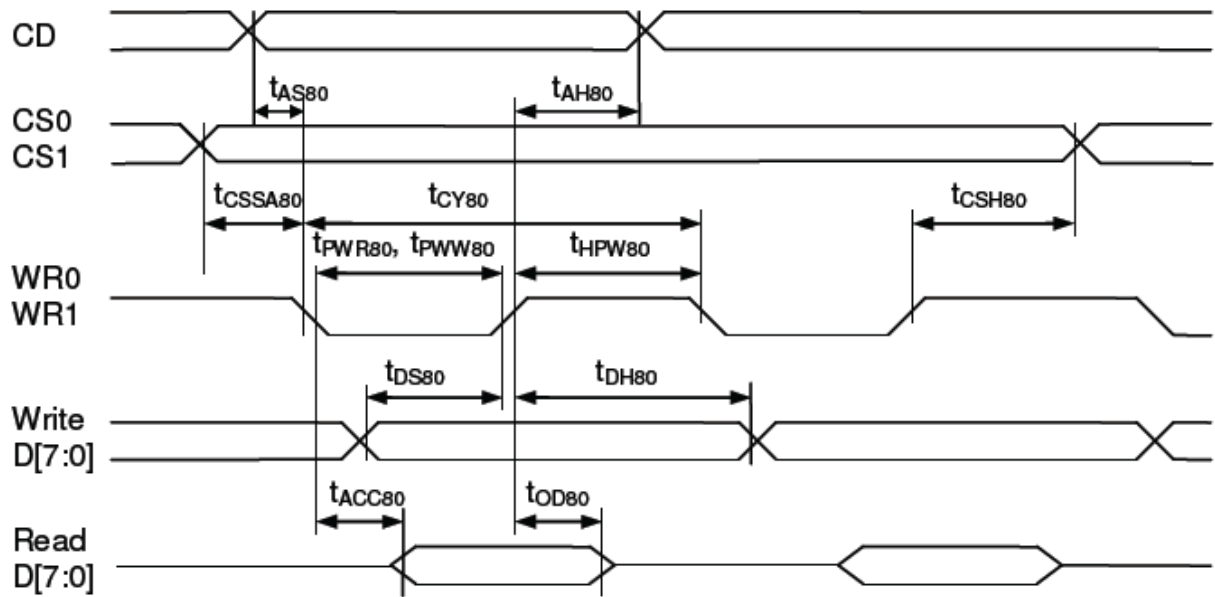

$V_{DD}=3.3V$ $V_{SS}=0V$, $T_{OP}=25^{\circ}C$

Item	Symbol	MIN.	MAX.	Unit
Address setup time (CD)	tas80	20	-	ns
Address hold time (CD)	tah80	26	-	ns
System cycle time (read)	tcy80	560	-	ns
System cycle time(write)	tcy80	364	-	ns
Read pulse width	tpwr80	260	-	ns
Write pulse width	tpww80	163	-	ns
High pulse width (read)	thpw80	260	-	ns
High pulse width (write)	thpw80	163	-	ns
Data setup time	tds80	59	-	ns
Data hold time	tdh80	13	-	ns
Data access time	tacc80	-	260	ns
Data output disable time	tod80	70	-	ns
Chip select setup time	tcssa80	7	-	ns
Chip select hold time	tcsh80	7	-	ns

Note:

- *1. Input signal rise/fall time should be less than 15ns .
- *2. CL=100pF
- *3.All timing is using 20% and 80% of VDD as the reference.

3.3.2 6800 Mode System Bus Timing

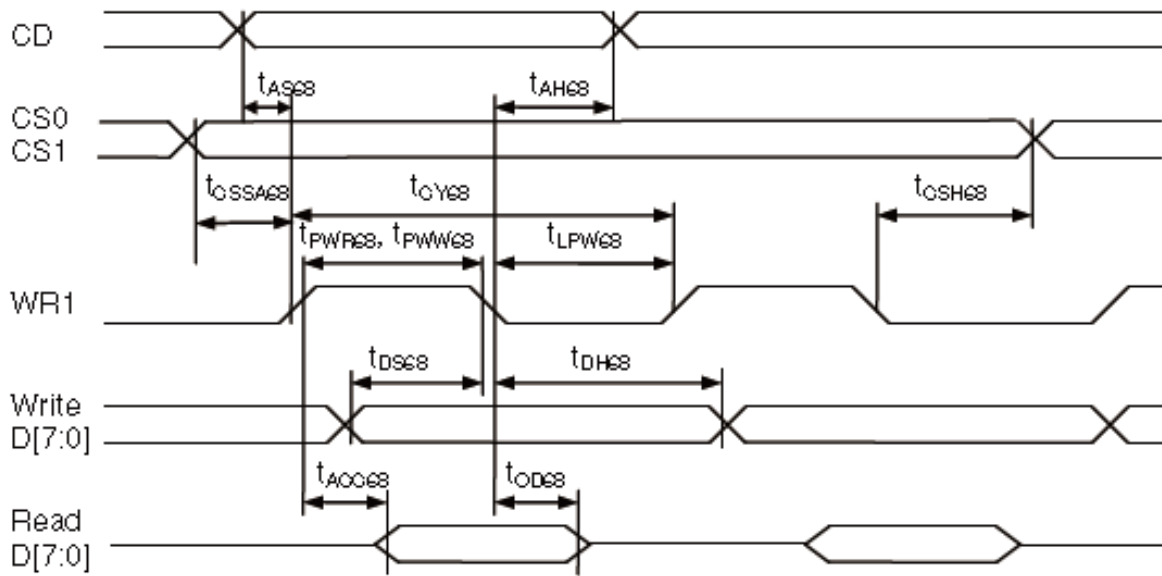

V_{SS}=0V, V_{DD}=3.3V, T_{OP}=25°C

Item	Symbol	MIN.	TYP.	MAX.	Unit
Address setup time	tAS68	15	-	-	ns
Address hold time	tAH68	20	-	-	ns
System cycle time(WRITE)	tCY68	280	-	-	ns
/WR L pulse width(WRITE)	tLPW68	125	-	-	ns
/WR H pulse width(WRITE)	tPWW68	125	-	-	ns
System cycle time(READ)	tCY68	430	-	-	ns
/RD L pulse width(READ)	tLPW68	200	-	-	ns
/RD H pulse width(READ)	tPWR	200	-	-	ns
WRITE Data setup time	tDS68	45	-	-	ns
WRITE Data hold time	tDH68	10	-	-	ns
READ access time	tACC68	-	-	200	ns
READ Output disable time	tOD68	100	-	-	ns

Note:

*1. Input signal rise/fall time should be less than 15ns .

*2. CL=100pF

*3.All timing is using 20% and 80% of VDD as the reference.

3.3.3 4-wire SPI w/ 8-bit token (S8)

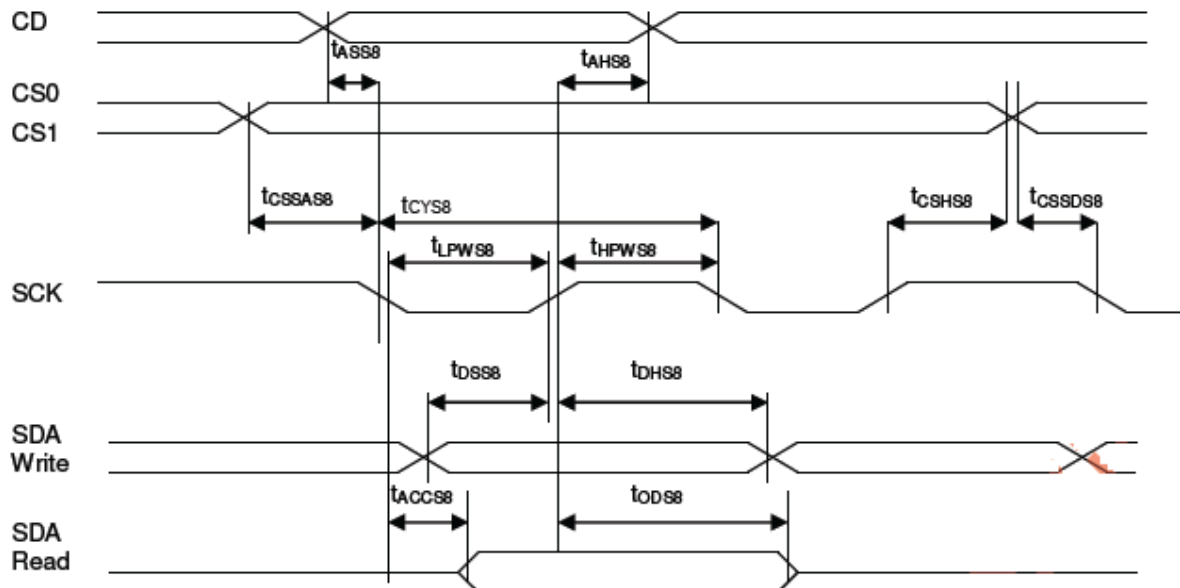

V_{DD}=3.3V V_{SS}=0V, T_{OP}=25°C

Item	Symbol	MIN.	MAX.	Unit
Address setup time (CD)	Tass8	0	-	ns
Address hold time (CD)	TAHs8	20	-	ns
System cycle time (read)	Tcys8	559	-	ns
System cycle time (write)	Tcys8	286	-	ns
Low pulse width(read)	tLPWS8	260	-	ns
Low pulse width(write)	tLPWS8	124	-	ns
High pulse width (read)	Thpws8	260	-	ns
High pulse width (write)	Thpws8	124	-	ns
Data setup time	Tdss8	33	-	ns
Data hold time	Tdhs8	20	-	ns
Data access time	Taccs8	-	260	ns
Data output disable time	Tods8	21	-	ns
Chip select setup time	tCSSAs8	7	-	ns
Chip select hold time	tCSHs8	20	-	ns

Note:

- *1. Input signal rise/fall time should be less than 15ns .
- *2. CL=100pF
- *3.All timing is using 20% and 80% of VDD as the reference.

3.3.4 I2C Mode System Bus Timing

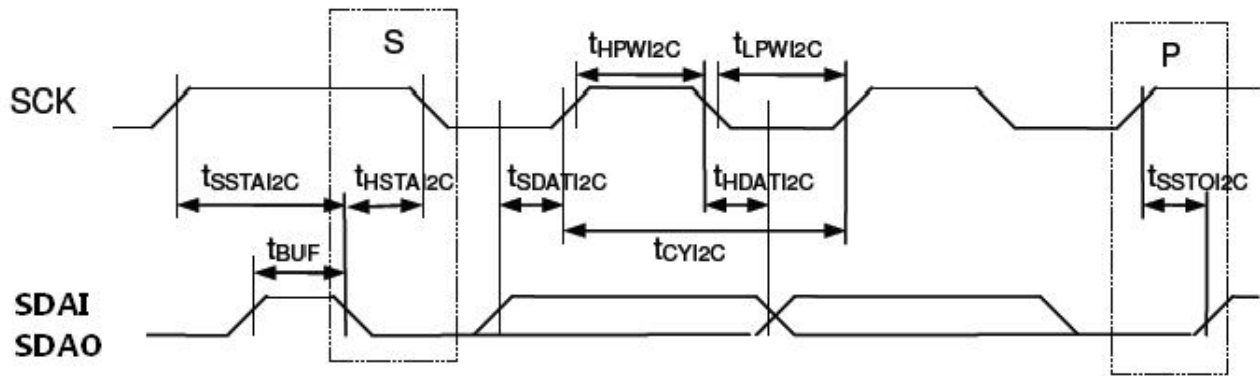

V_{DD}=3.3V V_{SS}=0V, T_{OP}=25°C

Item	Symbol	MIN.	MAX.	Unit
SCK cycle time(read)	tCY12C	689	-	ns
SCK cycle time(write)	tCY12C	299	-	ns
Low pulse width(read)	tLPWI2C	325	-	ns
Low pulse width(write)	tLPWI2C	130	-	ns
High pulse width(read)	tHPWI2C	325	-	ns
High pulse width(write)	tHPWI2C	130	-	ns
Rise time and fall time	tr, tf	-	-	ns
Data setup time	tSSDAI2C	72	-	ns
Data hold time	tHDAI2C	13	-	ns
START Setup time	tSSTA12C	13	-	ns
START Hold time	tHSTA12C	72	-	ns
STOP setup time	tSSTOI2C	13	-	ns
Bus Free time between STOP and START condition	tBUF	98	-	ns

Note:

- *1. Input signal rise/fall time should be less than 15ns .
- *2. CL=100pF
- *3.All timing is using 20% and 80% of VDD as the reference.

3.3.5 Reset Timing

V_{SS}=0V, V_{DD}=3.3V, T_{OP}=25°C

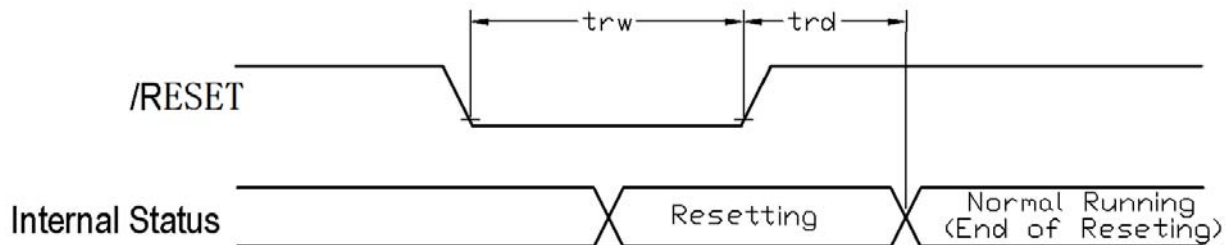

Item	Symbol	MIN.	TYP.	MAX.	Unit
Reset time	tr	4	-	-	μs
Reset LOW pulse width	trw	150	-	-	ms

Note:

- *1.All timing is using 20% and 80% of VDD as the reference.

4. Function specifications

4.1 Application circuit(Example)

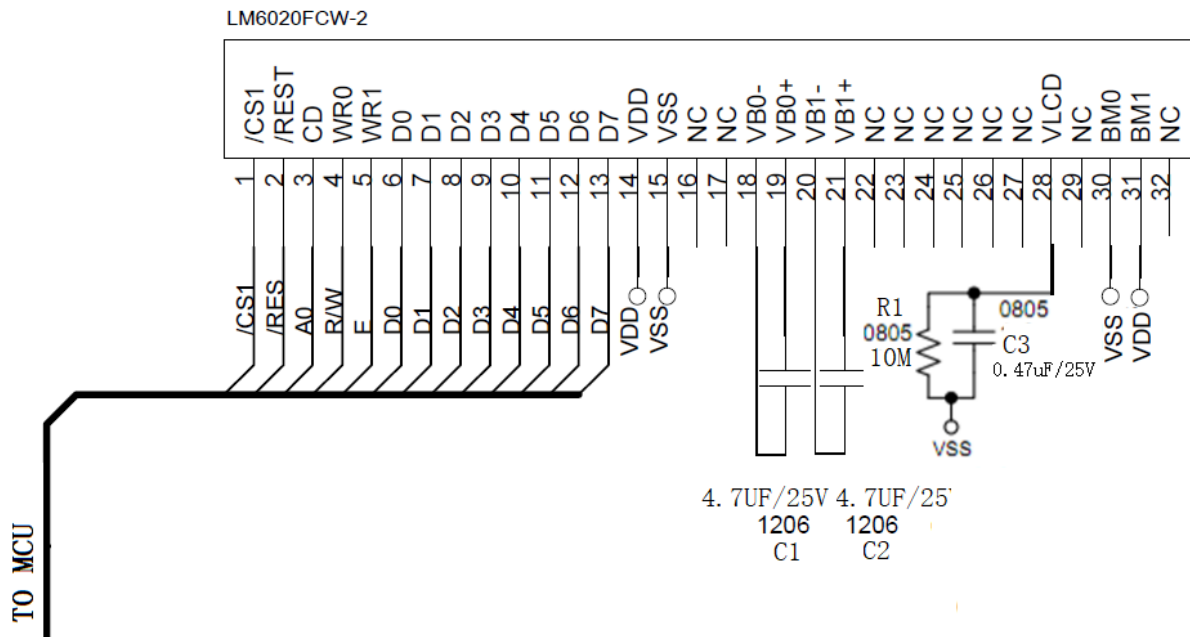

4.2 Adjusting the Display Contrast

-This LCD module equipped with latest digital contrast adjustment function.

-Its display contrast could be adjusted by MCU command. (please see the command tables for details)

-It is recommended to provide a contrast adjustment interface for end-user, where the best display result could meet the individual preference in mass production.

4.3 Basic Setting

To drive the LCD module correctly and provide normally display, please use the following setting

- Set Bias 1/10
- Set Duty 1/65
- MY = 1, MX =0
- AP=0 (Normal display)
- Analog SET
- Power control
- Display ON

Note:

*1. These setting/commands should issue the LCD module while start up.

*2. See the Display Commands section for details.

4.4 Resetting the LCD module

The LCD module should be initialized by using /RES terminal.

While turning on the VDD and VSS power supply, maintain /RES terminal at LOW level. After the power supply stabilized, release the reset terminal (/RES=HIGH)

4.5 Display Memory Map

Page address	data	LCD Display (front view)		
0	D7 : D0			
1	D7 : D0			
2	D7 : D0			
3	D7 : D0			
4	D7 : D0			
5	D7 : D0			
6	D7 : D0			
7	D7 : D0			
Column Address		00h	→	7Fh

Note:

- *1.MY=1
- *2.MX=0
- *3.Initial Display Line=0

4.6 Display Commands

The following is a list of host commands supported by UC1628c:

C/D: 0: Control, 1: Data **W/R**: 0: Write Cycle, 1: Read Cycle **D7-D0**: #: Useful Data bits -: Don't Care

#	Command	C/D	W/R	D7	D6	D5	D4	D3	D2	D1	D0	Action	Default
1.	Write Data Byte (double-byte command)	0	0	0	0	0	0	0	0	0	1	Write 1 byte	N/A
		1	0	#	#	#	#	#	#	#	#		
2.	Read Data Byte (double-byte command)	0	0	0	0	0	0	0	0	1	0	Read 1 byte	N/A
		1	1	#	#	#	#	#	#	#	#		
3.	Get Status (triple-byte command)	0	0	0	0	0	0	0	0	1	1	Get Status	N/A
		1	1	POR	MX	MY	PID	DE	OD	OE	OP		
		1	1	Ver[1:0]		PMO[5:0]							
4.	Set Column Address (double-byte command)	0	0	0	0	0	0	0	1	0	0	Set CA[7:0]	00H
		1	0	#	#	#	#	#	#	#	#		
5.	Set Temp. vs. Vop Control	0	0	0	0	0	1	0	0	0	#	Set TC[3]	0b
6.	Set Temp. vs. LR Control	0	0	0	0	0	1	0	0	1	#	Set TC[4]	0b
7.	Set Temp. Sensor Control	0	0	0	0	0	1	0	1	0	#	Set TC[5]	0b
8.	Set LR at Different temperature (triple-byte command)	0	0	0	0	0	1	0	1	1	0	Set TP[3:0] Set LR[4:0]	N/A
		1	0	0	0	0	0	#	#	#	#		
		1	0	0	0	0	#	#	#	#	#		
9.	Set LR (triple-byte command)	0	0	0	0	0	1	0	1	1	0	Set LR[4:0]	01101b
		1	0	0	0	0	0	0	0	0	0		
		1	0	0	0	0	#	#	#	#	#		
10.	Set Temperature Point (triple-byte command)	0	0	0	0	0	1	0	1	1	1	Set TP[3:0] Set ST[7:0]	N/A
		1	0	0	0	0	0	#	#	#	#		
		1	0	#	#	#	#	#	#	#	#		
11.	Set Temp. Compensagion	0	0	0	0	1	0	0	#	#	#	Set TC[2:0]	100b
12.	Set Pump Control	0	0	0	0	1	0	1	1	0	#	Set PC	1b
13.	Set Adv. Program Control (double-byte command)	0	0	0	0	1	1	0	0	R	R	R = 0, 1, 2 or 3	N/A
		1	0	#	#	#	#	#	#	#	#	Set APC[R][7:0]	
14.	Set Scroll Line	0	0	0	1	0	0	0	0	0	0	Set SL[7:0]	00H
		1	0	#	#	#	#	#	#	#	#		
15.	Set Page Address	0	0	0	1	1	0	0	0	0	0	Set PA[4:0]	00H
		1	0	0	0	0	#	#	#	#	#		
16.	Set PM at Different temperature (triple-byte command)	0	0	1	0	0	0	0	0	0	1	Set TP[3:0] Set PM[7:0]	N/A
		1	0	0	0	0	0	#	#	#	#		
		1	0	#	#	#	#	#	#	#	#		
17.	Set PM (triple-byte command)	0	0	1	0	0	0	0	0	0	1	Set PM[7:0]	54H
		1	0	0	0	0	0	0	0	0	0		
		1	0	#	#	#	#	#	#	#	#		

#	Command	G/D	W/R	D7	D6	D5	D4	D3	D2	D1	D0	Action	Default
18.	Set Partial Display Control	0	0	1	0	0	0	0	1	0	#	Set LC[3]	0b: Disable
19.	Set COM Scan Function	0	0	1	0	0	0	0	1	1	#	Set CSF	0b: Interlace
20.	Set RAM Address Control	0	0	1	0	0	0	1	#	#	#	Set AC[2:0]	001b
21.	Set All-Pixel-ON	0	0	1	0	1	0	0	1	0	#	Set DC[1]	0b
22.	Set Inverse Display	0	0	1	0	1	0	0	1	1	#	Set DC[0]	0b
23.	Set LCD Mapping Control	0	0	1	1	0	0	0	#	#	#	Set LC[2:0]	001b
24.	Set N-Line Inversion (double-byte command)	0	0	1	1	0	0	1	0	0	0	Set NIV[6:0]	00H
		1	0	0	#	#	#	#	#	#	#		
25.	Set Display Enable unlock Set Display Enable	0	0	1	1	0	0	1	0	0	1	Set DC[2]	0b
		1	0	1	0	1	0	1	1	0	#		
26.	NOP	0	0	1	1	1	0	0	0	1	1	No operation	N/A
27.	Set Test Control (double-byte command)	0	0	1	1	1	0	0	1	TT		For testing only.	N/A
		1	0	#	#	#	#	#	#	#	#	Do not use.	N/A
28.	Set LCD Bias Ratio	0	0	1	1	1	0	1	#	#	#	Set BR[2:0]	011b
29.	Reset Cursor update mode	0	0	1	1	1	1	0	1	1	0	AC[3]=0, CA=CR	N/A
30.	Set Cursor update mode	0	0	1	1	1	1	0	1	1	1	AC[3]=1, CR=CA	N/A
31.	Set COM End (double-byte command)	0	0	1	1	1	1	0	0	0	1	Set CEN[7:0]	161
		1	0	#	#	#	#	#	#	#	#		
32.	Set Partial Display Start (double-byte command)	0	0	1	1	1	1	0	0	1	0	Set DST[7:0]	0
		1	0	#	#	#	#	#	#	#	#		
33.	Set Partial Display End (double-byte command)	0	0	1	1	1	1	0	0	1	1	Set DEN[7:0]	161
		1	0	#	#	#	#	#	#	#	#		
34.	Set OTP Operation Control (double-byte command)	0	0	1	0	1	1	1	0	0	0	Set OTPC[4:0]	00H
		1	0	0	0	0	#	#	#	#	#		
35.	Set OTP Write Address (double-byte command)	0	0	1	0	1	1	1	0	0	1	Set OTPA[5:0]	00H
		1	0	0	0	#	#	#	#	#	#		

Note: *1. Do not use any other command not listed, or the system malfunction may result.
*2. For the details of the Display Commands, please refer to UC1628c data sheet.

4.6.1 Power off the LCD Module

It recommends that enter Sleep Mode before power off the LCD module.

4.6.2 Refreshing The LCD Module

It recommends that the operating modes and display contents be refreshed periodically to prevent the effect of unexpected noise.

5. Design and Handling Precaution

1. The LCD panel is made by glass. Any mechanical shock (eg. dropping from high place) will damage the LCD module.
2. Do not add excessive force on the surface of the display, which may cause the Display color change abnormally.
3. The polarizer on the LCD is easily get scratched. If possible, do not remove the LCD protective film until the last step of installation.
4. Never attempt to disassemble or rework the LCD module.
5. Only Clean the LCD with Isopropyl Alcohol or Ethyl Alcohol. Other solvents (eg. water) may damage the LCD.
6. When mounting the LCD module, make sure that it is free from twisting, warping and distortion.
7. Ensure to provide enough space (with cushion) between case and LCD panel to prevent external force adding on it, or it may cause damage to the LCD or degrade the display result.
8. Only hold the LCD module by its side. Never hold LCD module by add force on the heat seal or TAB.
9. Never add force to component of the LCD module. It may cause invisible damage or degrade of the reliability.
10. LCD module could be easily damaged by static electricity. Be careful to maintain an optimum anti-static work environment to protect the LCD module.
11. When peeling off the protective film from LCD, static charge may cause abnormal display pattern. It is normal and will resume to normal in a short while.
12. Take care and prevent get hurt by the LCD panel sharp edge.
13. Never operate the LCD module exceed the absolute maximum ratings.
14. Keep the signal line as short as possible to prevent noisy signal applying to LCD module.
15. Never apply signal to the LCD module without power supply.
16. IC chip (eg. TAB or COG) is sensitive to the light. Strong lighting environment could possibly cause malfunction. Light sealing structure casing is recommend.
17. LCD module reliability may be reduced by temperature shock.
18. When storing the LCD module, avoid exposure to the direct sunlight, high humidity, high temperature or low temperature. They may damage or degrade the LCD module

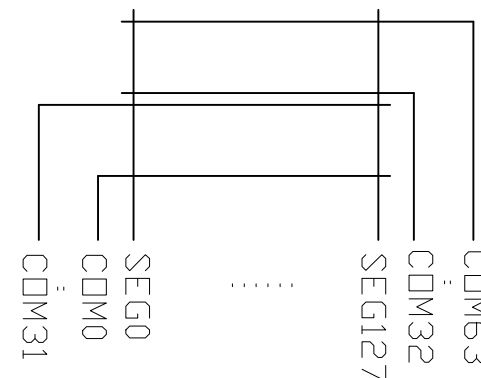
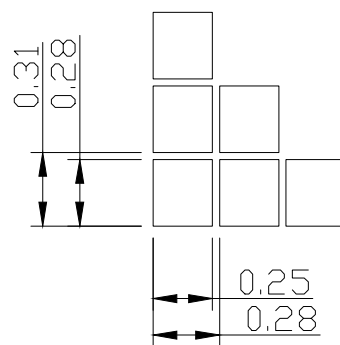
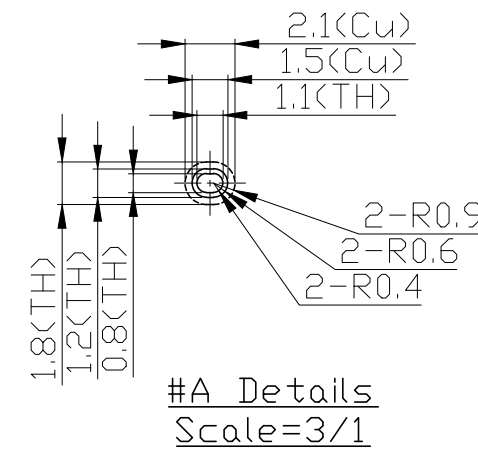
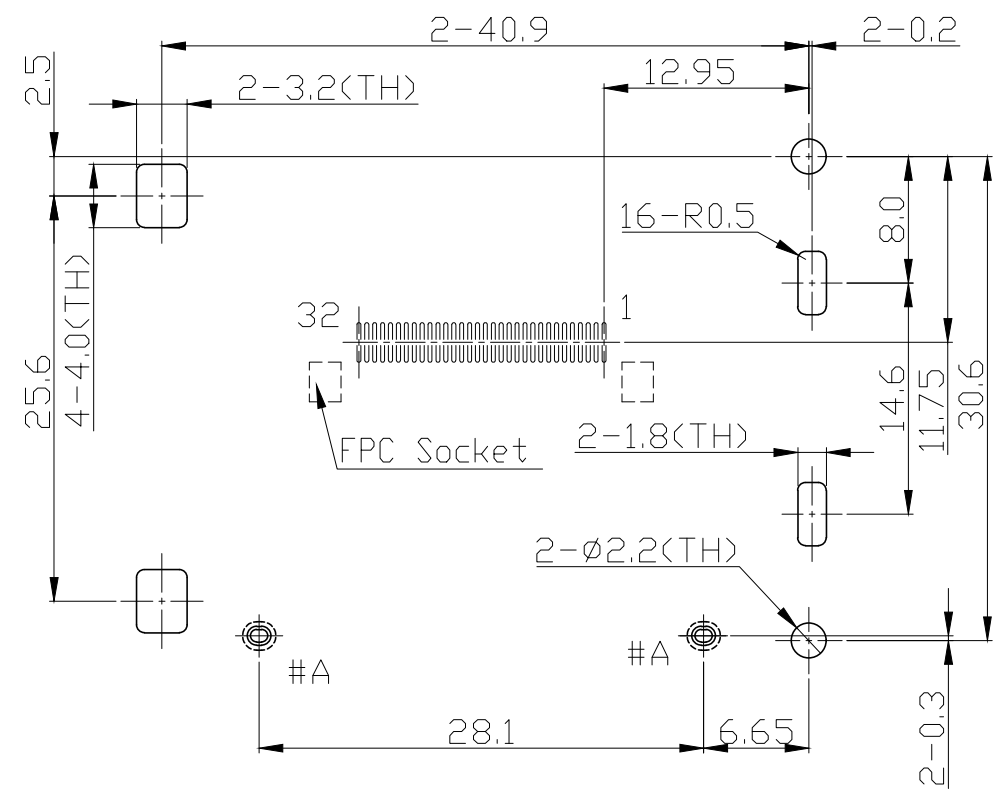
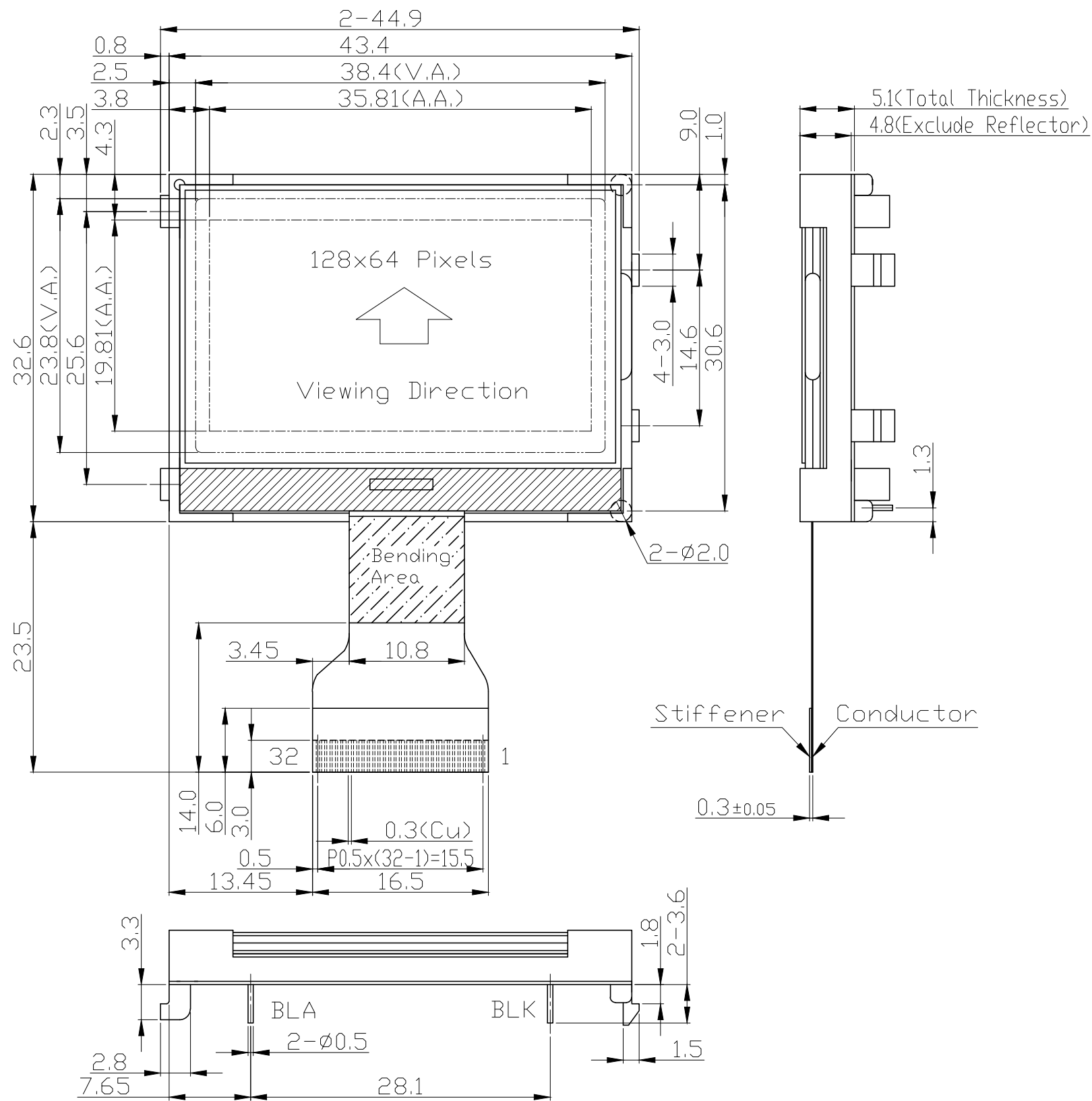

Terminal	
No.	Pin Name
1	/CS1
2	RESET
3	CD
4	WR0
5	WR1
6	D0
7	D1
8	D2
9	D3
10	D4
11	D5
12	D6
13	D7
14	VDD
15	VSS
16	NC
17	NC
18	VB0-
19	VB0+
20	VB1-
21	VB1+
22	NC
23	NC
24	NC
25	NC
26	NC
27	NC
28	VLCD
29	NC
30	BM0
31	BM1
32	NC

- Note:
- *1. Display Type : FSTN, Positive, Transflective
 - *2. Viewing Direction : 6H
 - *3. Duty : 1/65, Bias : 1/10
 - *4. Operating Voltage : 3.3V
 - *5. Backlight Supply : 3.3V TYP.
 - *6. Backlight Color : White
 - *7. Operating Temperature : -40°C~70°C
 - *8. Storage Temperature : -40°C~80°C
 - *9. Application PCB thickness : 1.6mm

C		
B		
A		
Rev	Note	Date
Dwg	Title	
Dwg No.	MK-007114-1-1	Date
Scale	2/1	2020-11-24
Tol.	±0.3	
Unit	mm	Paper Size
Approved	Checked	A3
		Drawn
		Luo Lin

TOPWAY