



深圳市拓普微科技开发有限公司
SHENZHEN TOPWAY TECHNOLOGY CO.,LTD.

LM6038FDW-2

LCD Module User Manual

Prepared by: Huchubin Date:2020-09-02	Checked by: Date:	Approved by: Date:
---	----------------------------------	-----------------------------------

Rev.	Descriptions	Release Date
0.1	Preliminary release	2020-09-02

Table of Content

1. Basic Specifications	3
1.1 Display Specifications	3
1.2 Mechanical Specifications	3
1.3 Block Diagram.....	3
1.4 Terminal Functions.....	4
1.5 Jumper Functions.....	4
2. Absolute Maximum Ratings	5
3. Electrical Characteristics	5
3.1 DC Characteristics	5
3.2 LED Backlight Circuit Characteristics	5
3.3 AC Characteristics	6
3.4 Reset Timing	9
4. Function specifications.....	9
4.1 The Parallel Interface	9
4.2 The Serial Interface	9
4.3 Basic Setting	10
4.4 Resetting the LCD module	10
4.5 Display Memory Map.....	10
4.6 Display Commands	11
4.7 Display Commands (continue)	12
4.8 Basic Operating Sequence (example).....	13
5. Design and Handling Precaution	14

1. Basic Specifications

1.1 Display Specifications

- 1) LCD Display Mode : STN-GRAY, Positive, Transmissive
- 2) Display Color : Display Data = "1" : Deep Blue(*1)
: Display Data = "0" : Light Gray (*2)
- 3) Viewing Angle : 6H
- 4) Driving Method : 1/65 duty, 1/9 bias
- 5) Backlight : White LED backlight

Note:

*1. Color tone may slightly change by Temperature and Driving Condition.

*2. The Color is defined as the inactive / background color

1.2 Mechanical Specifications

- 1) Outline Dimension : 84.0 x 54.0 x 11.1MAX (mm)
(See attached Outline Drawing for details)

1.3 Block Diagram

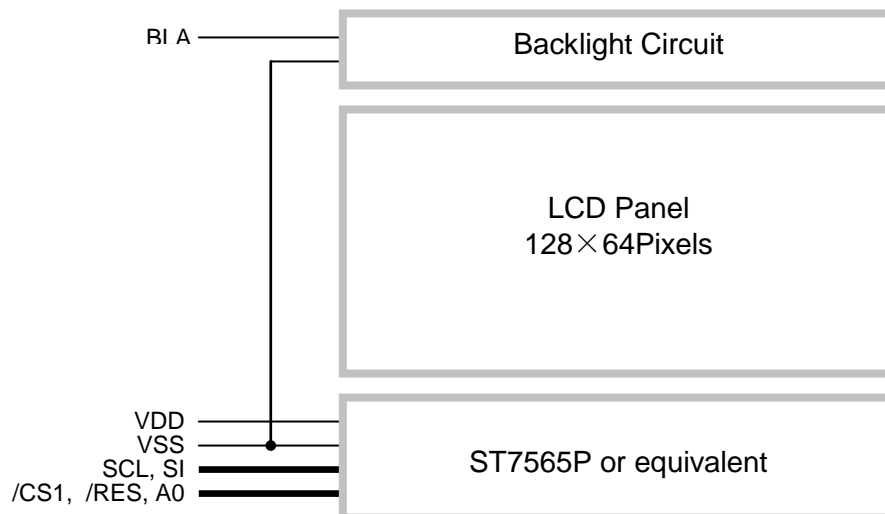

1.4 Terminal Functions

PIN NO	PIN Name	I/O	Descriptions		
			8-bit parallel 8080 mode	8-bit parallel 6800 mode	Serial mode
1	/CS1	Input	Chip Select /CS1=L, enable access to the LCD module /CS1=H, disable access to the LCD module		
2	/RES	Input	Reset signal /RES = L, Initialization is executed /RES = H, Normal running.		
3	A0	Input	Register Select A0 = H, Transferring the Display Data A0 = L, Transferring the Control Data		
4	/WR (R/W)	Input	/WR=L→H, /RD=H; Data or Instruction latch into the LCD module	R/W=H,E=H; Data or Status read from the LCD module R/W=L,E=H→L; Data or Status latch into the LCD module	Not used, Leave open or pull Hi
5	/RD (E)	Input	/WR=H, /RD=L; Data or Status read form the LCD module		
6	D0	I/O	8-bit Data bus; Three state I/O terminal for display data or instruction data when /CS=H, D0~D7=High Impedance		Not used, Leave open
:	:	I/O			
11	D5	I/O			
12	D6(SCL)	I/O			Serial clock input
13	D7(SI)	I/O			Serial data input
14	VDD	Supply	Positive power supply		
15	VSS	Supply	Negative power supply,0V		
16	BLA	Supply	Positive power for LED backlight		

1.5 Jumper Functions

JP1	JP2	JP3	JP4	Interface Mode
CLOSE	OPEN	CLOSE	OPEN	6800 Mode
OPEN	CLOSE	CLOSE	OPEN	8080 Mode
OPEN	CLOSE	OPEN	CLOSE	Serial Mode (default)

2. Absolute Maximum Ratings

Items	Symbol	Min.	Max.	Unit	Condition
Supply Voltage	V_{DD}	-0.3	+3.3	V	$V_{SS} = 0V$
Input Voltage	V_{IN}	-0.3	$V_{DD}+0.3$	V	$V_{SS} = 0V$
Operating Temperature	T_{OP}	-20	+70	°C	No Condensation
Storage Temperature	T_{ST}	-30	+80	°C	No Condensation

Cautions:

Any Stresses exceeding the Absolute Maximum Ratings may cause substantial damage to the device. Functional operation of this device at other conditions beyond those listed in the specification is not implied and prolonged exposure to extreme conditions may affect device reliability.

3. Electrical Characteristics

3.1 DC Characteristics

$V_{SS}=0V, V_{DD}=3.0V, T_{OP}=25^{\circ}C$

Items	Symbol	MIN.	TYP.	MAX.	Unit	Condition / Application Pin
Operating Voltage	V_{DD}	2.8	-	3.3	V	VDD
Input High Voltage	V_{IH}	$0.8 \times V_{DD}$	-	V_{DD}	V	/RES, /CS1, A0,
Input Low Voltage	V_{IL}	V_{SS}	-	$0.2 \times V_{DD}$	V	/WR, /RD, D0~D7
Output High Voltage	V_{OH}	$0.75 \times V_{DD}$	-	V_{DD}	V	D0~D7
Output Low Voltage	V_{OL}	V_{SS}	-	$0.25 \times V_{DD}$	V	D0~D7
Operating Current	I_{DD}	-	0.3	1.7	mA	VDD

3.2 LED Backlight Circuit Characteristics

$V_{SS}=0V, I_f=75mA, T_{OP}=25^{\circ}C$

Items	Symbol	MIN	TYP	MAX	Unit	Applicable Pin
Forward Voltage	$V_{f_{BLA}}$	-	3.3	-	V	BLA
Forward Current	$I_{f_{BLA}}$	-	75	100	mA	BLA

Cautions:

Exceeding the recommended driving current could cause substantial damage to the backlight and shorten its lifetime.

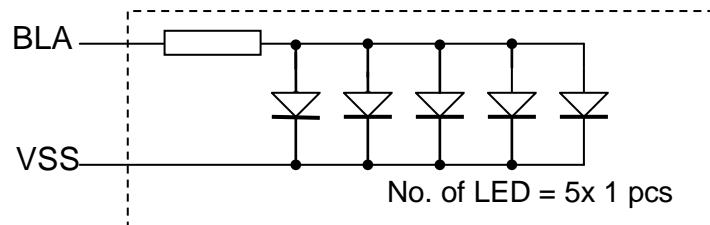

3.3 AC Characteristics

3.3.1 Serial Mode Interface

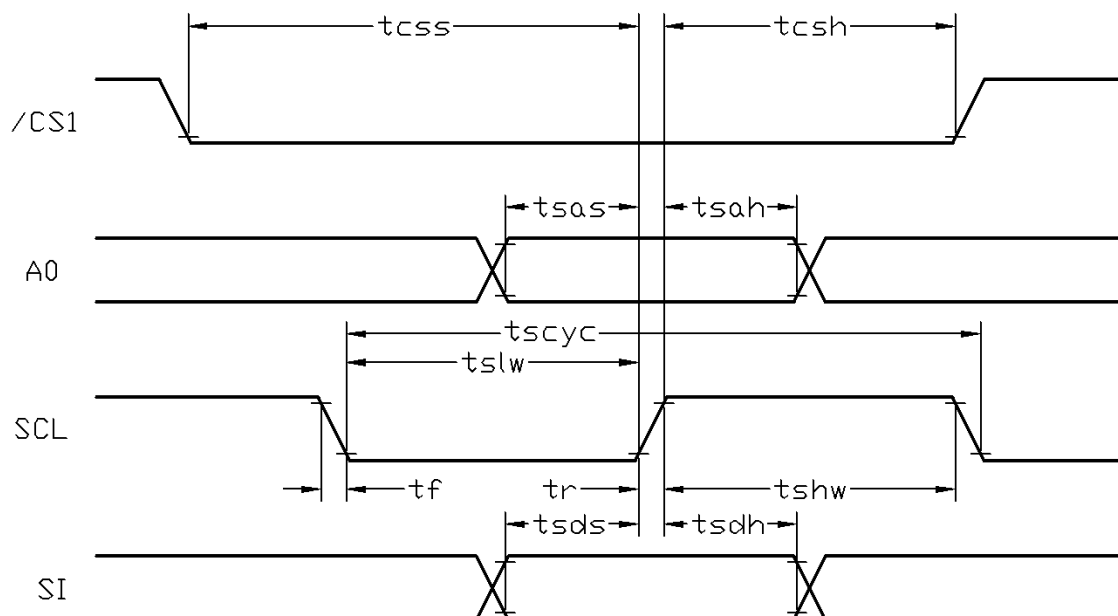

$V_{SS}=0V, V_{DD}=3.0V, T_{OP}=25^{\circ}C$

Item	Symbol	MIN.	TYP.	MAX.	Unit
Serial Clock Period	tscyc	125	-	-	ns
Address setup time (A0)	tsas	38	-	-	ns
Address hold time (A0)	tsah	25	-	-	ns
SCL "H" pulse width	tshw	63	-	-	ns
SCL "L" pulse width	tslw	63	-	-	ns
Data setup time	tsds	38	-	-	ns
Data hold time	tsdh	25	-	-	ns
CS-SCL time	tcss	38	-	-	ns
CS-SCL time	tcsh	75	-	-	ns

Note:

*1. Input signal rise/fall time should be less than 15ns .

*2. CL=100pF

*3.All timing is using 20% and 80% of VDD as the reference.

3.3.2 8080 Mode System Bus Timing

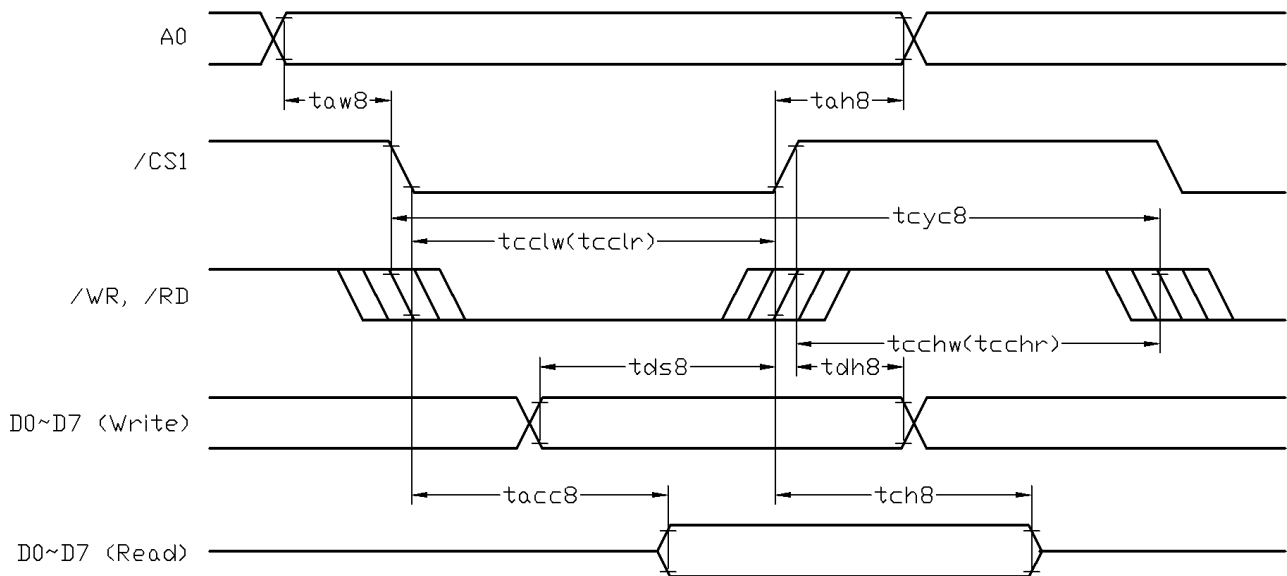

$V_{SS}=0V, V_{DD}=3.0V, T_{OP}=25^{\circ}C$

Item	Symbol	MIN.	TYP.	MAX.	Unit
System cycle time	t_{cyc8}	500	-	-	ns
Address setup time (A0)	t_{aw8}	10	-	-	ns
Address hold time (A0)	t_{ah8}	10	-	-	ns
Control LOW pulse width (/RD)	t_{cclr}	275	-	-	ns
Control LOW pulse width (/WR)	t_{cclw}	275	-	-	ns
Control HIGH pulse width (/RD)	t_{cchr}	225	-	-	ns
Control HIGH pulse width (/WR)	t_{cchw}	225	-	-	ns
Data setup time	t_{ds8}	50	-	-	ns
Data hold time	t_{dh8}	10	-	-	ns
/RD access time (*2)	t_{acc8}	-	-	175	ns
Output disable time (*2)	t_{ch8}	13	-	125	ns

Note:

*1. Input signal rise/fall time should be less than 15ns .

*2.All timing is using 20% and 80% of VDD as the reference.

3.3.3 6800 Mode System Bus Timing

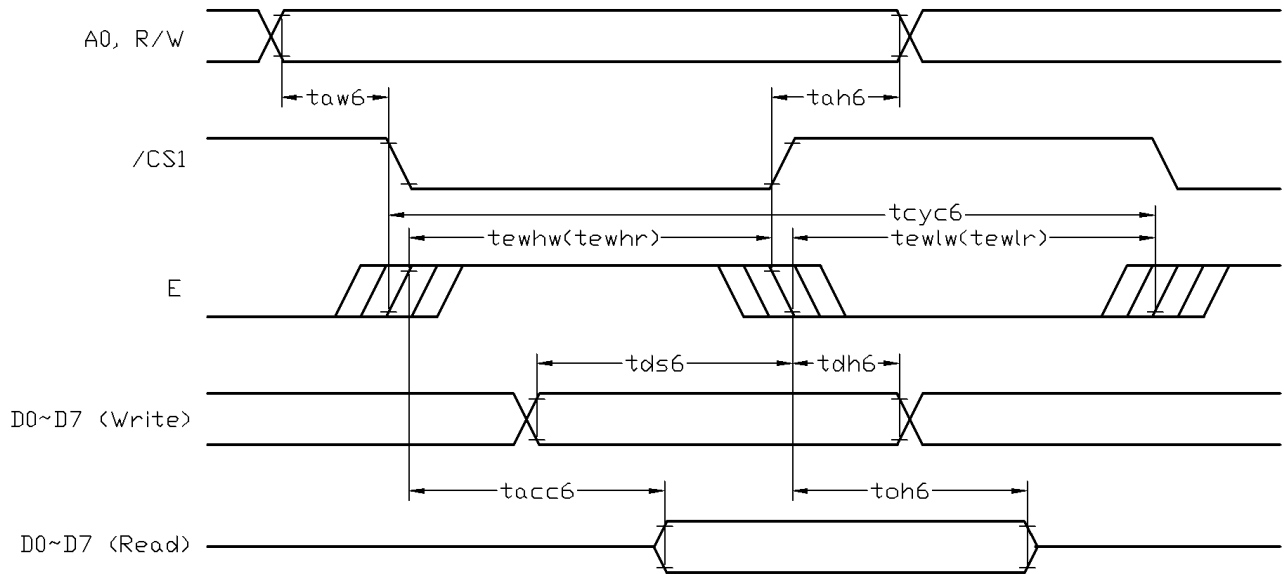

$V_{SS}=0V, V_{DD}=3.0V, T_{OP}=25^{\circ}C$

Item	Symbol	MIN.	TYP.	MAX.	Unit
System cycle time	tcyc6	500	-	-	ns
Address setup time (A0)	taw6	10	-	-	ns
Address hold time (A0)	tah6	10	-	-	ns
Control LOW pulse width (/RD)	tewlr	275	-	-	ns
Control LOW pulse width (/WR)	tewlw	275	-	-	ns
Control HIGH pulse width (/RD)	tewhr	225	-	-	ns
Control HIGH pulse width (/WR)	tewhw	225	-	-	ns
Data setup time	tds6	50	-	-	ns
Data hold time	tdh6	10	-	-	ns
/RD access time (*2)	tacc6	-	-	175	ns
Output disable time (*2)	tch6	13	-	125	ns

Note:

*1. Input signal rise/fall time should be less than 15ns .

*2. CL=100pF

*3.All timing is using 20% and 80% of VDD as the reference.

3.4 Reset Timing

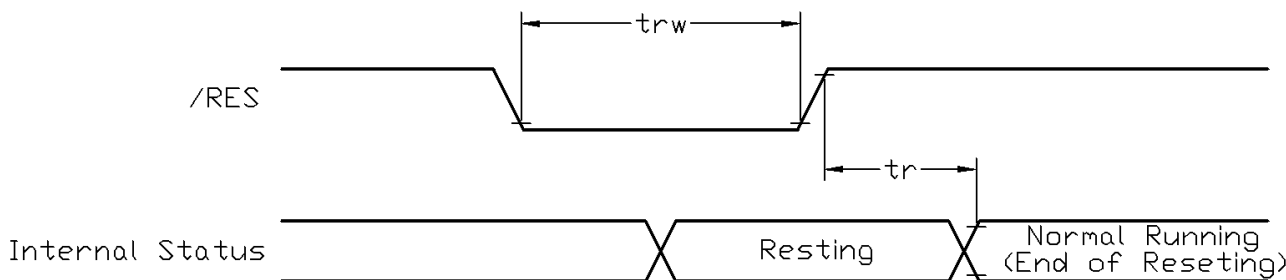

$V_{SS}=0V, V_{DD}=3.0V, T_{OP}=25^{\circ}C$

Item	Symbol	MIN.	TYP.	MAX.	Unit
Reset time	tr	-	-	2.5	μs
Reset LOW pulse width	trw	2.5	-	-	μs

Note:

*1.All timing is using 20% and 80% of VDD as the reference.

4. Function specifications

4.1 The Parallel Interface

Shared	6800 Mode		8080 Mode		Function		
	A0	R/W	E	/RD		/WR	
H	H	H	L	L	H	Reads the display data	
H	L	H	H	H	L	L	Writes the display data
L	H	H	L	L	H	H	Status read
L	L	H	H	H	L	L	Write control data(command)

4.2 The Serial Interface

When the serial interface has been selected then when the chip is in active state the serial data input(SI) and the serial clock(SCL) can be received. The serial data is read from the serial data input pin in the rising edge of the serial clock . When "A0"="H", the data is display data, and when "A0"="L", the data is command.

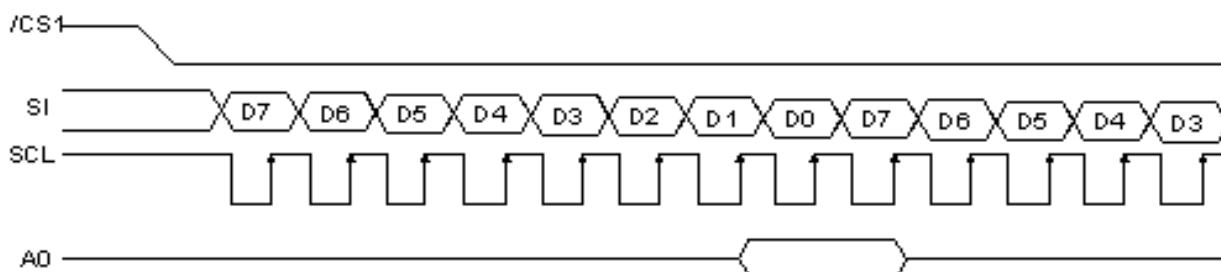

4.3 Basic Setting

To drive the LCD module correctly and provide normally display, please use the following setting

- ADC = 0 (normal)
- SHL select = 1 (reverse)
- LCD Bias Select = 1/9
- Initial Display Line = 0
- Entire Display ON/OFF = OFF (normal)
- Reverse Display ON/OFF = OFF (normal)
- Set Power Control Set:
voltage follower = ON, voltage converter = ON, voltage regulator = ON
- Display ON/OFF = ON

Note:

*1. These setting/commands should issue the LCD module while start up.

*2. See the Display Commands section for details.

4.4 Resetting the LCD module

The LCD module should be initialized by using /RES terminal.

While turning on the VDD and VSS power supply, maintain /RES terminal at LOW level. After the power supply stabilized, release the reset terminal (/RES=HIGH)

4.5 Display Memory Map

Page address	data	LCD Display (front view)	
0	D0 : D7		
1	D0 : D7		
2	D0 : D7		
3	D0 : D7		
4	D0 : D7		
5	D0 : D7		
6	D0 : D7		
7	D0 : D7		
Column Address		04h	→ 83h

Note:

*1. ADC = 0 (normal)

*2. SHL Selection = 1 (reverse)

*3. Initial Display Line = 0

4.6 Display Commands

No.	Instructions	Code											Function
		a0	/RD	/WR	D7	D6	D5	D4	D3	D2	D1	D0	
1	Display ON/OFF	0	1	0	1	0	1	0	1	1	1	DON	DON=0, display off DON=1, display on
2	Display start line set	0	1	0	0	1	Display start address						Sets the display RAM display start line address
3	Set Page Address	0	1	0	1	0	1	1	Page Address				Set the display RAM page address
4	Set Column Address (Upper-4-bits)	0	1	0	0	0	0	1	Col. Add. Upper				Set the upper-4-bit of column address counter
	Set Column Address (Lower-4-bits)	0	1	0	0	0	0	0	Col. Add. Lower				Set the lower-4-bit of column address counter
5	Read Status	0	0	1	Status				0	0	0	0	Read the status data
6	Write Display Data	1	1	0	Write Data								Write data into the display RAM
7	Read Display Data	1	0	1	Read Data								Read data from the display RAM
8	ADC Select	0	1	0	1	0	1	0	0	0	0	ADC	Sets the display RAM address SEG output correspondence ADC=0, normal . ADC=1, reverse
9	Normal/Reverse Display	0	1	0	1	0	1	0	0	1	1	REV	REV=0, Normal display REV=1, Reverse display
10	Entire Display ON/OFF	0	1	0	1	0	1	0	0	1	0	EON	EON=0, Normal display EON=1, Entire display ON
11	Set LCD Bias	0	1	0	1	0	1	0	0	0	1	BIAS	Set the LCD driving voltage bias BIAS=0, 1/9 BIAS BIAS=1, 1/7 BIAS
12	Set Read-Modify-Write	0	1	0	1	1	1	0	0	0	0		Enter the "Read-Modify-Write" mode column address counter will increase in each "Write Display Data", and will not increase in each "Read Display Data command"
13	Reset Read-Modify-Write	0	1	0	1	1	1	0	1	1	1	0	Clear the "Read-Modify-Write" mode
14	Reset	0	1	0	1	1	1	0	0	0	1	0	Resets the LCD module
15	SHL Select	0	1	0	1	1	0	0	SHL	*	*	*	Set the COM scanning direction SHL=0, Normal display SHL=1, Flipped in y direction * = don't care terms
16	Power Control Set	0	1	0	0	0	1	0	1	VC	VR	VF	Set the power circuit operation mode VF: LCD Supply Voltage Follower VR: LCD Supply Voltage Regulator VC: LCD Supply Voltage Converter (1=ON, 0=OFF)
17	Regulator Resistor Select	0	1	0	0	0	1	0	0	Radio setting			Set the built-in resistor ratio (Rb/Ra)

Note: *1. Do not use any other command not listed, or the system malfunction may result.

*2. For the details of the Display Commands, please refer to ST7565P data sheet.

4.7 Display Commands (continue)

No.	Instructions	Code										Function	
		A0	/RD	/WR	D7	D6	D5	D4	D3	D2	D1		D0
18	Electronic volume mode set	0	1	0	1	0	0	0	0	0	0	1	Set reference voltage mode
	Electronic volume register set	0	1	0	*	*	Electronic Control value					Set reference voltage register (Display contrast value)	
19	Power Save	-	-	-	-	-	-	-	-	-	-	-	Compound Instruction: Display OFF + Entire Display ON
20	NOP	0	1	0	1	1	1	0	0	0	1	1	Non-operation command

Note: *1. Do not use any other command not listed, or the system malfunction may result.
*2. For the details of the Display Commands, please refer to ST7565P data sheet.

4.7.1 Power off the LCD Module

It recommends that enter Power Save mode before power off the LCD module.

4.7.2 Refreshing The LCD Module

It recommends that the operating modes and display contents be refreshed periodically to prevent the effect of unexpected noise.

4.8 Basic Operating Sequence (example)

4.8.1 Initialization Sequence

		Code Function										Note	
A0	D7	D6	D5	D4	D3	D2	D1	D0	hex				
Turn on Power Supply VDD & VSS While maintaining /RES at LOW		-	-	-	-	-	-	-	-	-	-	-	-
Wait until power supply is stabilized		-	-	-	-	-	-	-	-	-	-	-	-
Release the /RES Reset Signal (/RES = HIGH)		-	-	-	-	-	-	-	-	-	-	-	See AC Characteristics section for timing details
LCD bias = 1/9		0	1	0	1	0	0	0	1	0	A2h	LCD panel Characteristic	
ADC = normal		0	1	0	1	0	0	0	0	0	A0h	No flip on x-direction (SEG)	
SHL = reverse		0	1	1	0	0	1	0	0	0	C8h	Flip on y-direction (COM)	
Initial Display Line=0		0	0	1	0	0	0	0	0	0	40h	i.e. Display RAM "page 0 - D0" Matched to top line of the LCD	
Power Control Voltage Follower = OFF Voltage Regulator = OFF Voltage Converter = ON Delay 50ms		0	0	0	1	0	1	1	0	0	2Ch	Turn on the internal Voltage Converter and wait until VOUT stable.	
Power Control Voltage Follower = OFF Voltage Regulator = ON Voltage Converter = ON Delay 50ms		-	-	-	-	-	-	-	-	-	-	-	
Power Control Voltage Follower = ON Voltage Regulator = ON Voltage Converter = ON Delay 50ms		0	0	0	1	0	1	1	1	0	2Eh	Turn on the Internal Voltage Regulator and wait until VOUT stable.	
Regulator Resistor Select		-	-	-	-	-	-	-	-	-	-	-	
Set Reference Voltage Mode		0	0	0	1	0	1	1	1	1	2Fh	Turn on the internal Voltage Follower and wait until VOUT stable	
Set Reference Voltage Resistor		-	-	-	-	-	-	-	-	-	-	-	
Display ON		0	0	0	1	0	0	1	0	1	25h	Set the built-in resistor ratio to middle	
Set Page Address = 0		0	1	0	0	0	0	0	0	1	81h	Set to the middle of the range It may be adjusted for achieving the best display contrast	
Set Column Address (Upper-4bit=0)		0	0	0	1	0	0	0	0	0	20h		
Set Column Address (Lower-4bit=4)		0	0	0	0	1	0	0	0	0			
Write Display Data		0	1	0	1	0	1	1	1	1	AFh	Turn on the LCD display	
Write Other Display Data ...		0	1	0	1	1	0	0	0	0	B0h	Specify the Display Data RAM page address to 00h	
		0	0	0	0	1	0	0	0	0	10h	Specify the Display Data RAM column address to 00h	
		0	0	0	0	0	0	1	0	0	04h		
Write Display Data		1	Display Data									Write data to Display Data RAM. After write, the internal Column Address Counter will be increased by 1 automatically	

5. Design and Handling Precaution

1. The LCD panel is made by glass. Any mechanical shock (eg. dropping from high place) will damage the LCD module.
2. Do not add excessive force on the surface of the display, which may cause the Display color change abnormally.
3. The polarizer on the LCD is easily get scratched. If possible, do not remove the LCD protective film until the last step of installation.
4. Never attempt to disassemble or rework the LCD module.
5. Only Clean the LCD with Isopropyl Alcohol or Ethyl Alcohol. Other solvents (eg. water) may damage the LCD.
6. When mounting the LCD module, make sure that it is free from twisting, warping and distortion.
7. Ensure to provide enough space (with cushion) between case and LCD panel to prevent external force adding on it, or it may cause damage to the LCD or degrade the display result.
8. Only hold the LCD module by its side. Never hold LCD module by add force on the heat seal or TAB.
9. Never add force to component of the LCD module. It may cause invisible damage or degrade of the reliability.
10. LCD module could be easily damaged by static electricity. Be careful to maintain an optimum anti-static work environment to protect the LCD module.
11. When peeling off the protective film from LCD, static charge may cause abnormal display pattern. It is normal and will resume to normal in a short while.
12. Take care and prevent get hurt by the LCD panel sharp edge.
13. Never operate the LCD module exceed the absolute maximum ratings.
14. Keep the signal line as short as possible to prevent noisy signal applying to LCD module.
15. Never apply signal to the LCD module without power supply.
16. IC chip (eg. TAB or COG) is sensitive to the light. Strong lighting environment could possibly cause malfunction. Light sealing structure casing is recommend.
17. LCD module reliability may be reduced by temperature shock.
18. When storing the LCD module, avoid exposure to the direct sunlight, high humidity, high temperature or low temperature. They may damage or degrade the LCD module

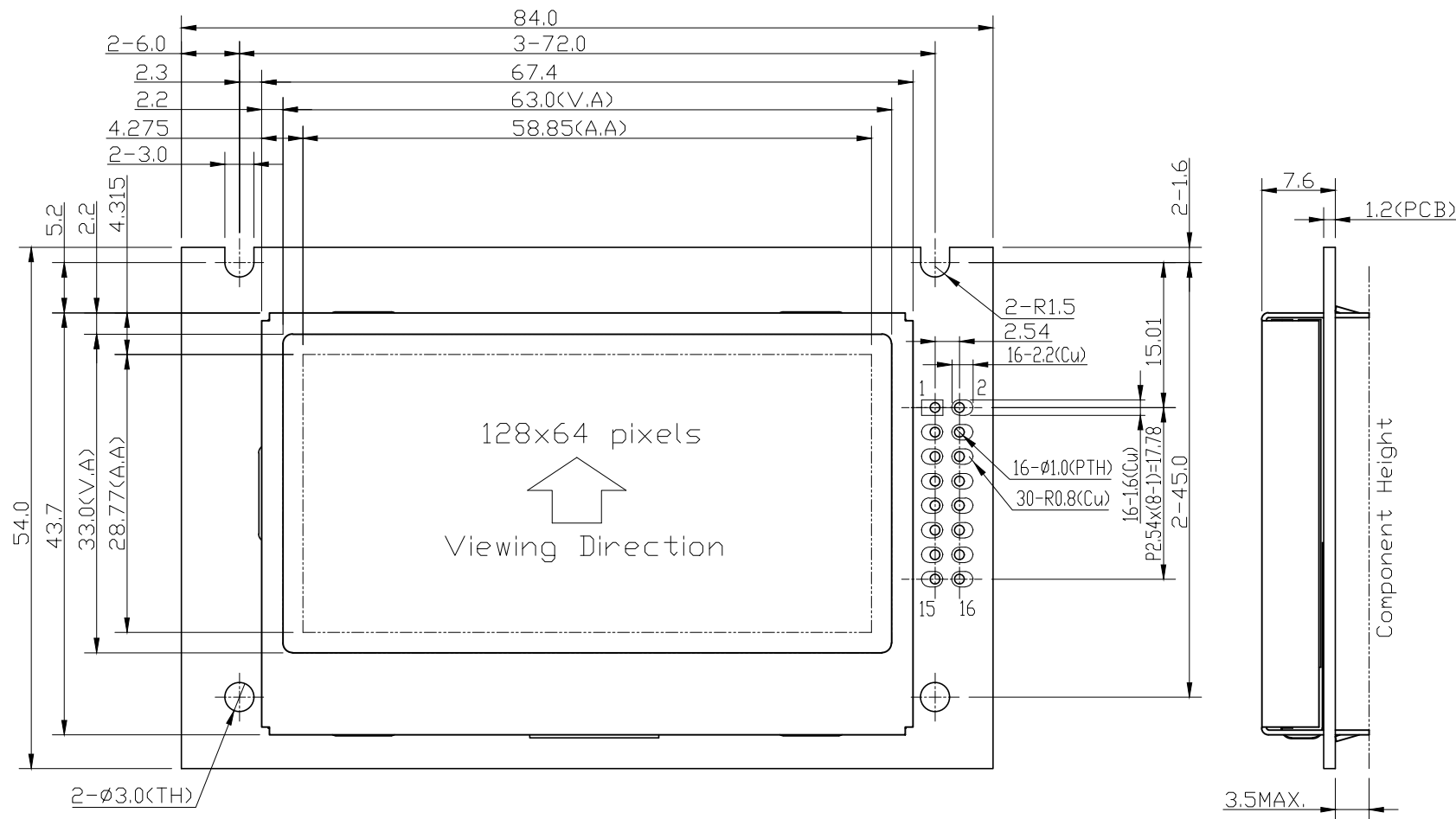

Terminal	
No.	Pin Name
1	/CS1
2	/RES
3	A0
4	NC
5	NC
6	NC
7	NC
8	NC
9	NC
10	NC
11	NC
12	SCL
13	SI
14	VDD
15	VSS
16	BLA

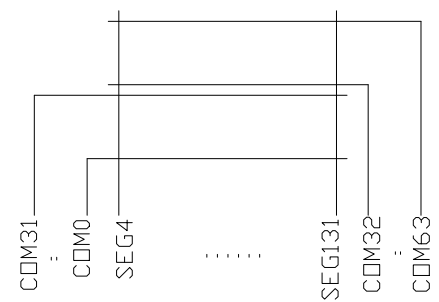
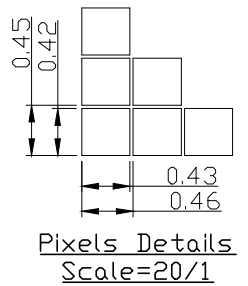

Wiring Details
(Top View)
Scale=free

- Note:
- *1. LCD Display Type : STN-GRAY, Positive, Transmissive
 - *2. Viewing Direction : 6H
 - *3. Duty : 1/65, Bias : 1/9
 - *4. Operating Voltage : 3.3V
 - *5. Backlight Color : White
 - *6. Backlight Supply : 75mA (3.3V TYP.)
 - *7. Operating Temperature : -20°C~70°C
 - *8. Storage Temperature : -30°C~80°C

C		
B		
A		
Rev	Note	Date
Dwg Title LM6038FDW-2 Outline Dwg		
Dwg No. MK-007026-1-1		Date 2020-08-26
Scale 2/1	Tol. ±0.5	Unit mm
Paper Size A3		Drawn Qiu Shaoping
Approved	Checked	

