



深圳市拓普微科技开发有限公司

SHENZHEN TOPWAY TECHNOLOGY CO.,LTD.

MODEL NO : LMT121ENLFWA
MODEL VERSION: 00
SPEC VERSION : V2.0
ISSUED DATE: 2021-03-23

- Preliminary Specification
 Final Product Specification

Topway Confirmed :

Prepared by	Checked by	Approved by
wangxikuan		

Table of Contents

Table of Contents	2
Record of Revision	3
1 General Specifications.....	4
2 Input/Output Terminals	5
3 Absolute Maximum Ratings.....	6
4 Electrical Characteristics	7
5 Timing Chart.....	13
6 Optical Characteristics	16
7 Environmental / Reliability Test.....	20
8 Mechanical Drawing	21
9 Precautions For Use of LCD Modules	22

Record of Revision

Rev	Issued Date	Description	Editor
1.0	2019-01-25	Preliminary Specification Released.	wangxikaun
1.1	2019-10-23	Update more details.	wangxikaun
1.2	2020-03-10	Update mechanical drawing(modify screw hole of short side) on page18.	wangxikaun
1.3	2020-04-01	Modify display direction on page5. Update timing on page10.	wangxikaun
1.4	2020-08-06	Update vibration test condition on page17	wangxikaun
2.0	2021-03-23	Final Version Released.	wangxikaun

1 General Specifications

	Feature	Spec
Display Spec.	Size	12.1 inch
	Resolution	1280(RGB) x 800
	Technology Type	SFT
	Pixel Configuration	R.G.B. Vertical Stripe
	Pixel Pitch (mm)	0.204x0.204
	Display Mode	Transmissive, Normally Black
	Surface Treatment(Up Polarizer)	AG
	Viewing Direction	All direction
Mechanical Characteristics	LCM (W x H x D) (mm)	278.0x184.0x9.9
	Active Area(mm)	261.1x163.2
	With /Without TSP	Without Touch Screen
	Matching Connection Type	JAE:FI-X30CL
	Weight (g)	445
Electrical Characteristics	Interface	1port LVDS, 6/8bit selectable
	Color Depth	16.7M/262k

Note 1: Viewing direction for best image quality is different from TFT definition, there is a 180 degree shift.

Note 2 : Requirements on Environmental Protection: Q/S0002

Note 3 : LCM weight tolerance : +/- 5%

2 Input/Output Terminals

2.1 TFT LCD Panel

Connector type: MSAKT2407P30HB(STM) Matching Connector: JAE FI-X30CL or compatible

No	Symbol	I/O	Description	Comment
1	VLED	P	Backlight power supply +12V	
2	VLED	P	Backlight power supply +12V	
3	VLED	P	Backlight power supply +12V	
4	VLED	P	Backlight power supply +12V	
5	VLED_EN	I	Backlight on/off control (1: ON, 0:OFF)	
6	VLED_PWM	I	Backlight dimming control	
7	GND	P	Power ground	
8	GND	P	Power ground	
9	VDD	P	Power Supply +3.3V	
10	VDD	P	Power Supply +3.3V	
11	GND	P	Power ground	
12	GND	P	Power ground	
13	Rxin0-	I	-LVDS differential data input(R0~R5,G0)	
14	Rxin0+	I	+LVDS differential data input(R0~R5,G0)	
15	GND	P	Power ground	
16	Rxin1-	I	-LVDS differential data input(G1~G5,B0~B1)	
17	Rxin1+	I	+LVDS differential data input(G1~G5,B0~B1)	
18	GND	P	Power ground	
19	Rxin2-	I	-LVDS differential data input(B2~B5,HS,VS,DE)	
20	Rxin2+	I	+LVDS differential data input(B2~B5,HS,VS,DE)	
21	GND	P	Power ground	
22	RxCLK-	I	-LVDS differential data input	
23	RxCLK+	I	+LVDS differential data input	
24	GND	P	Power ground	
25	Rxin3-	I	-LVDS differential data input(R6~R7,G6~G7,B6~B7)	
26	Rxin3+	I	+LVDS differential data input(R6~R7,G6~G7,B6~B7)	
27	GND	P	Power ground	
28	SEL6/8	I	Low-->6 bit input mode High or NC-->8 bit input mode	
29	GND	P	Power ground	
30	GND	P	Power ground	

Note1: I/O definition: I-----Input P----Power/Ground

Note2: Display direction (PCB at down side)

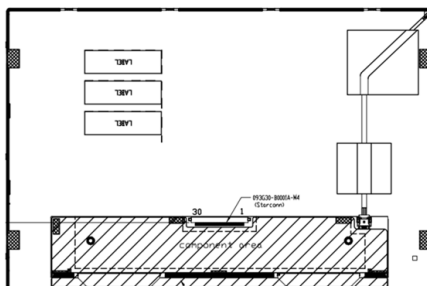

3 Absolute Maximum Ratings

3.1 Driving TFT LCD Panel

GND=0V

Item	Symbol	MIN	MAX	Unit	Remark
Voltage Input	VDD	-0.50	4.00	V	Stress Rating.
LED power	VLED	-0.50	33V	V	
LED control	VLED_EN、 VLED_PWM	-0.50	5.5V	V	
Operating Temperature	T _{op}	-20.0	70.0	°C	
Storage Temperature	T _{st}	-30.0	80.0	°C	
Relative Humidity (Note1)	RH	--	≤95	%	Ta≤40°C
		--	≤85	%	40°C < Ta ≤ 50°C
		--	≤55	%	50°C < Ta ≤ 60°C
		--	≤36	%	60°C < Ta ≤ 70°C
		--	≤24	%	70°C < Ta ≤ 80°C
Absolute Humidity	AH	--	≤70	g/m ³	Ta > 70°C

Table 3.1 absolute maximum rating

Note1: Ta means the ambient temperature.

It is necessary to limit the relative humidity to the specified temperature range.

Condensation on the module is not allowed.

4 Electrical Characteristics

4.1 Driving TFT LCD Panel

VCC=3.3V,GND=0V, Ta=25°C

Item	Symbol	MIN	TYP	MAX	Unit	Remark
Power supply Voltage	VDD	3.00	3.30	3.60	V	Include ripple
Power supply ripple	Vp-p	-	-	100	mV	
Power supply current	IDD	-	200	-	mA	
Power consumption	P	-	660	-	mW	Note1
Differential input voltage	Vid	200	-	600	mV	
Differential input common voltage	V _{CM}	1	1.2	1.4	V	
Differential input threshold voltage	Low level	VTL	-100	-	-	mV
	High level	VTH	-	-	100	mV
Inrush current	Irush	-	-	1.5	A	Note2

Table 4.1 LCD module electrical characteristics

Note1: To test the current dissipation, using the “white pattern” shown.

VDD rising time is 470μs

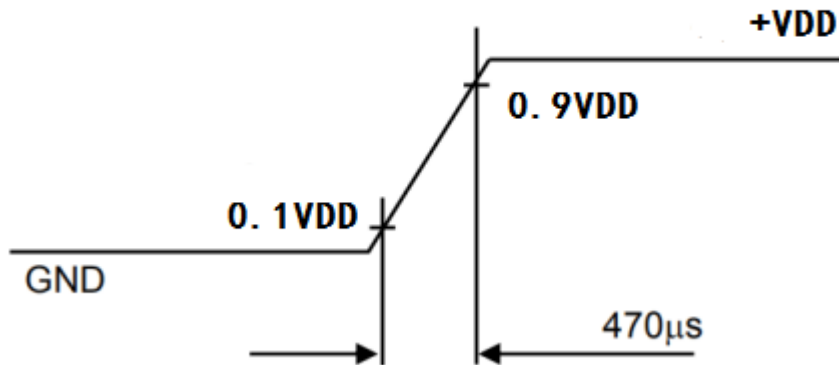

Note2: Inrush current definition.

4.2 LVDS DC electrical characteristics

Parameter	Symbol	Min.	Typ.	Max.	Unit	Condition
Differential input high threshold voltage	R_{XVTH}	-	-	+0.1	V	$R_{XVCM}=1.2V$
Differential input low threshold voltage	R_{XVTL}	-0.1	-	-	V	
Input voltage range (singled-end)	R_{XVIN}	0.7	-	1.7	V	
Differential input common mode voltage	R_{XVCM}	1	1.2	1.4	V	$ V_{ID} =0.2$
Differential input impedance	Z_{ID}	80	100	125	ohm	
Differential input voltage	$ V_{ID} $	0.2	-	0.6	V	
Differential input leakage current	I_{LCLVDS}	-10	-	+10	uA	
LVDS Digital Operating Current	I_{VDD}	-	15	20	mA	$F_{DCLK}=80MHz, VDD=3.3V$, Input pattern: 55h->Aah->55h->Aah
LVDS Digital Stand-by Current	I_{ST}	-		250	uA	Clock & all Functions are stopped

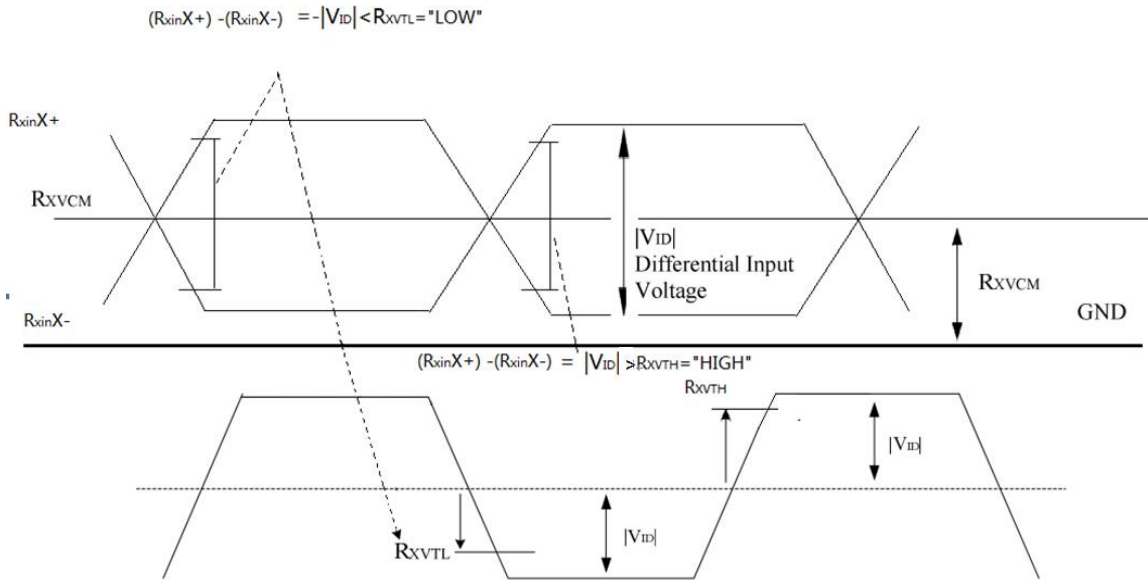

Figure 4.2.1 LVDS DC characteristics

Parameter	Symbol	Min.	Typ.	Max.	Unit
Clock frequency	F_{LVCCYC}	68	73	78	MHz
Clock period	T_{LVCCYC}			-	ps
1 data bit time	UI	-	1/7	-	T_{LVCCYC}
Clock high time	T_{LVCH}	3.9	4	4.1	UI
Clock low time	T_{LVCL}	2.9	3	3.1	UI
Position 1	T_{POS1}	-0.2	0	0.2	UI
Position 0	T_{POS0}	0.8	1	1.2	UI
Position 6	T_{POS6}	1.8	2	2.2	UI
Position 5	T_{POS5}	2.8	3	3.2	UI
Position 4	T_{POS4}	3.8	4	4.2	UI
Position 3	T_{POS3}	4.8	5	5.2	UI
Position 2	T_{POS2}	5.8	6	6.2	UI
Input eye width	T_{EYEW}	0.6	-	-	UI
Input eye border	T_{EX}	-	-	0.2	UI
LVDS wake up time	T_{ENLVDS}	-	-	150	us

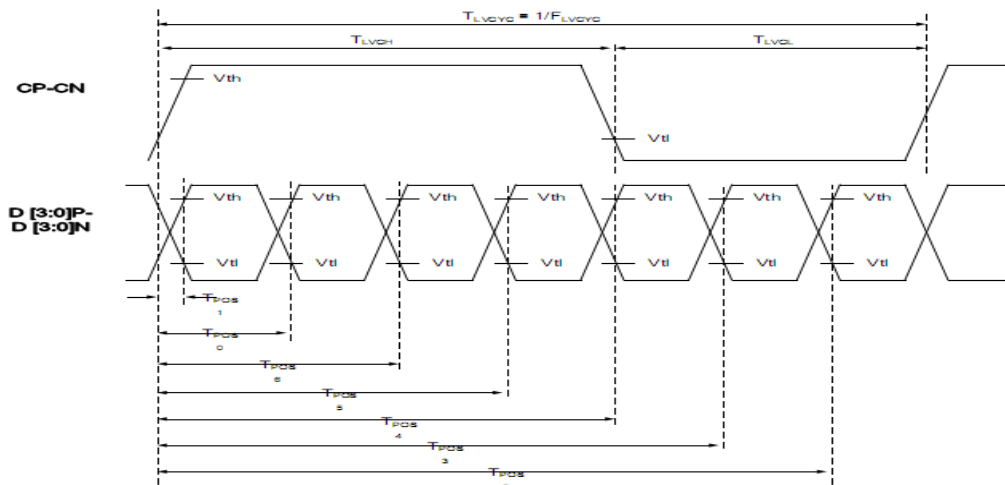

Figure 4.2.2 LVDS signal characteristics

4.3 LVDS AC electrical characteristics

Parameter	Symbol	Spec.			Unit	Condition
		Min.	Typ.	Max.		
Clock frequency	R_{xFCLK}	30	-	TBD	MHz	Refer to input timing table for each display resolution
Input data skew margin	T_{RSKM}	500	-	-	ps	$ VID = 200mV$ $RxVCM = 1.2V$ $RxFCLK = 81MHz$
Clock high time	T_{LVCH}	-	$4/(7 * R_{xFCLK})$	-	ns	
Clock low time	T_{LVCL}	-	$3/(7 * R_{xFCLK})$	-	ns	
PLL wake-up time	T_{enPLL}	-	-	150	us	

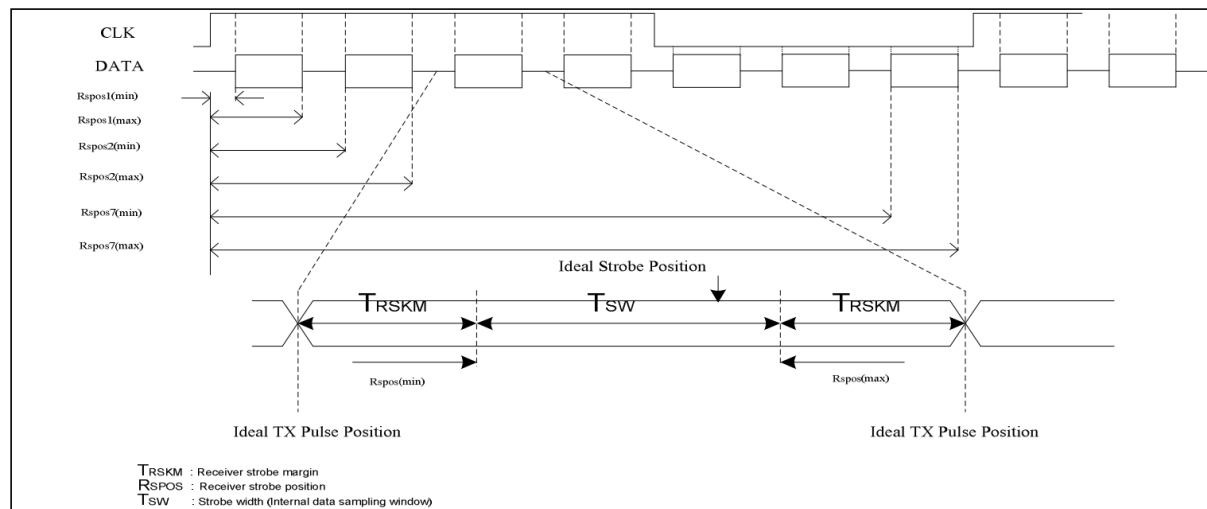
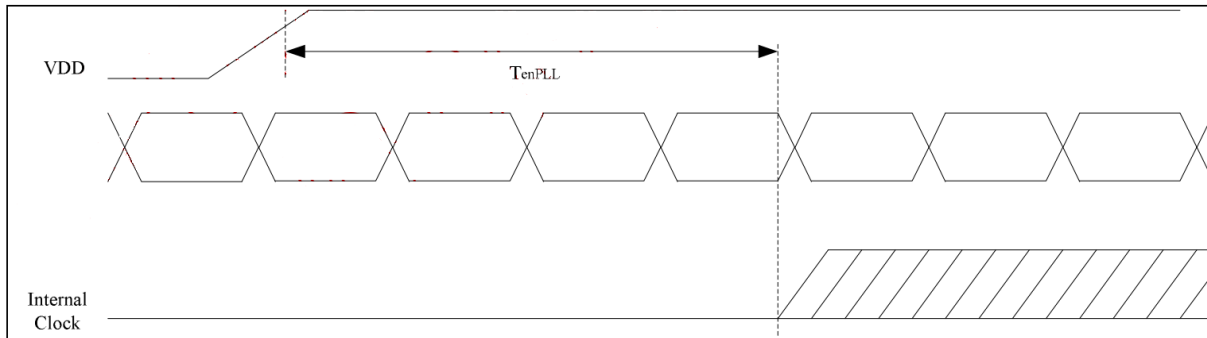
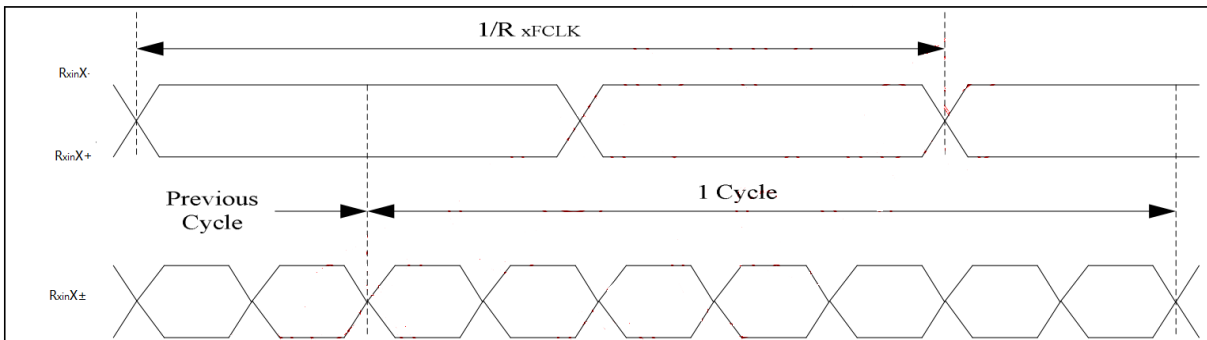

Figure 4.3 LVDS AC electrical characteristics

Note: The min value of clock frequency(30MHZ) is based on IC SPEC, user should set on suggested value(refer to page13).

4.4 Driving Backlight

Ta=25°C

Item	Symbol	Min	Typ	Max	Unit	Remark
Backlight power supply voltage	VLED	11	12	13	V	
Backlight power supply current	I_LED	-	787	-	mA	
Backlight power consumption	P_LED	-	9444	-	mW	
Input voltage for VLED_PWM signal	High level	-	1.2	-	5.0	V
	Low level	-	0	-	0.35	V
Input voltage for VLED_EN	High level	-	1.5	-	5.0	V
	Low level	-	0	-	0.8	V
VLED_PWM frequency	Fpwm	200	-	10K	HZ	
VLED_PWM duty	D	3	-	100	%	Note1
Operating Life Time	--	50000	-	--	hrs	Note2
Inrush current	IR	-	-	1.5	A	Rising time:470us

Table 4.4 Backlight driving condition

Note 1: According to LED driver IC characteristics, the minimum value of VLED_PWM duty may vary with VLED_PWM frequency, higher the frequency, bigger the duty.

Note 2: Optical performance should be evaluated at Ta=25°C only.

Note 3: If LED is driven by high current, high ambient temperature & humidity condition. The life time of LED will be reduced.

Note 4: Operating life means brightness goes down to 50% of initial brightness. Typical operating life time is estimated data.

4.5 Block Diagram

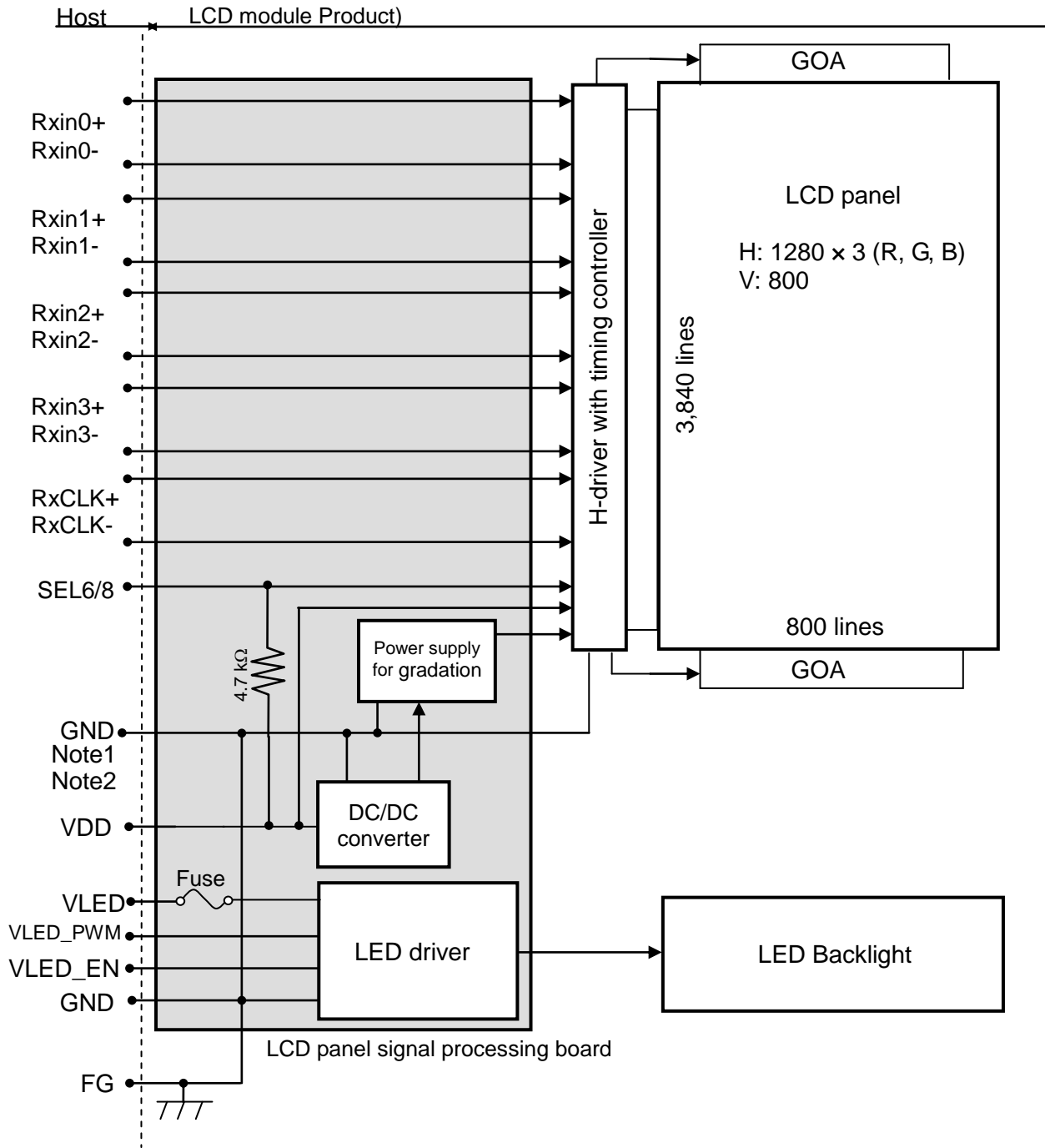

Note1: Relations between GND (Signal ground and LED driver ground) and FG (Frame ground) in the LCD module are as follows:

GND - FG	Connected
----------	-----------

Note2: GND and FG must be connected to customer equipment's ground, and it is recommended that these grounds be connected together in customer equipment.

5 Timing Chart

5.1 LVDS signal timing characteristics

VCC=3.3V, GND=0V, Ta=25°C

Parameter	Symbol	Value			Unit	Note
		min	typ	max		
CLK frequency	t _{clk}	68	73	78	Mhz	
Horizontal blanking time	t _{HBT}	102	162	222	t _{clk}	t _{HBP} + t _{HFP} + t _{HPW}
Horizontal back porch	t _{HBP}	88			t _{clk}	
Horizontal display area	t _{HD}	1280			t _{clk}	
Horizontal front porch	t _{HFP}	-	72	-	t _{clk}	
Horizontal period	t _H	1382	1442	-	t _{clk}	
Horizontal pulse width	t _{HPW}	-	2	-	t _{clk}	
Vertical blanking time	t _{VBT}	26	40	74	t _H	t _{VBP} + t _{VFP} + t _{VPW}
Vertical back porch	t _{VBP}	23			t _H	
Vertical display area	t _{VD}	800			t _H	
Vertical front porch	t _{VFP}	-	15	-	t _H	
Vertical period	t _V	826	840	874	t _H	
Vertical pulse width	t _{VPW}		2		t _H	

Table 5.1 timing parameter

Note: Blanking setting must be even numbers.

5.2 Input Clock and Data timing Diagram:

Vertical timing

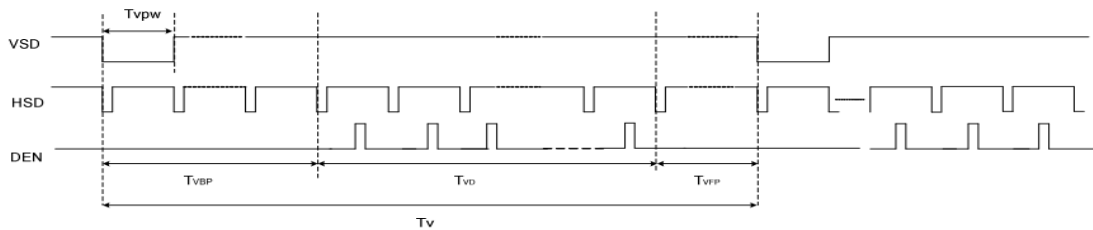

Horizontal timing

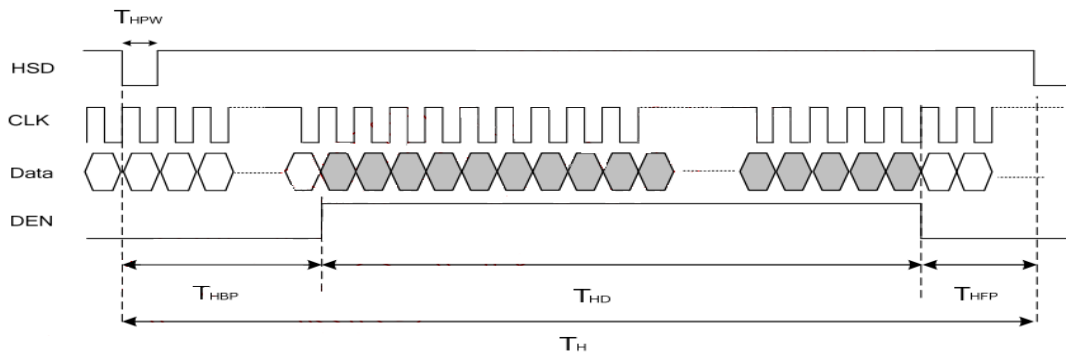

Figure 5.2 Input signal data timing

5.3 LVDS data input format

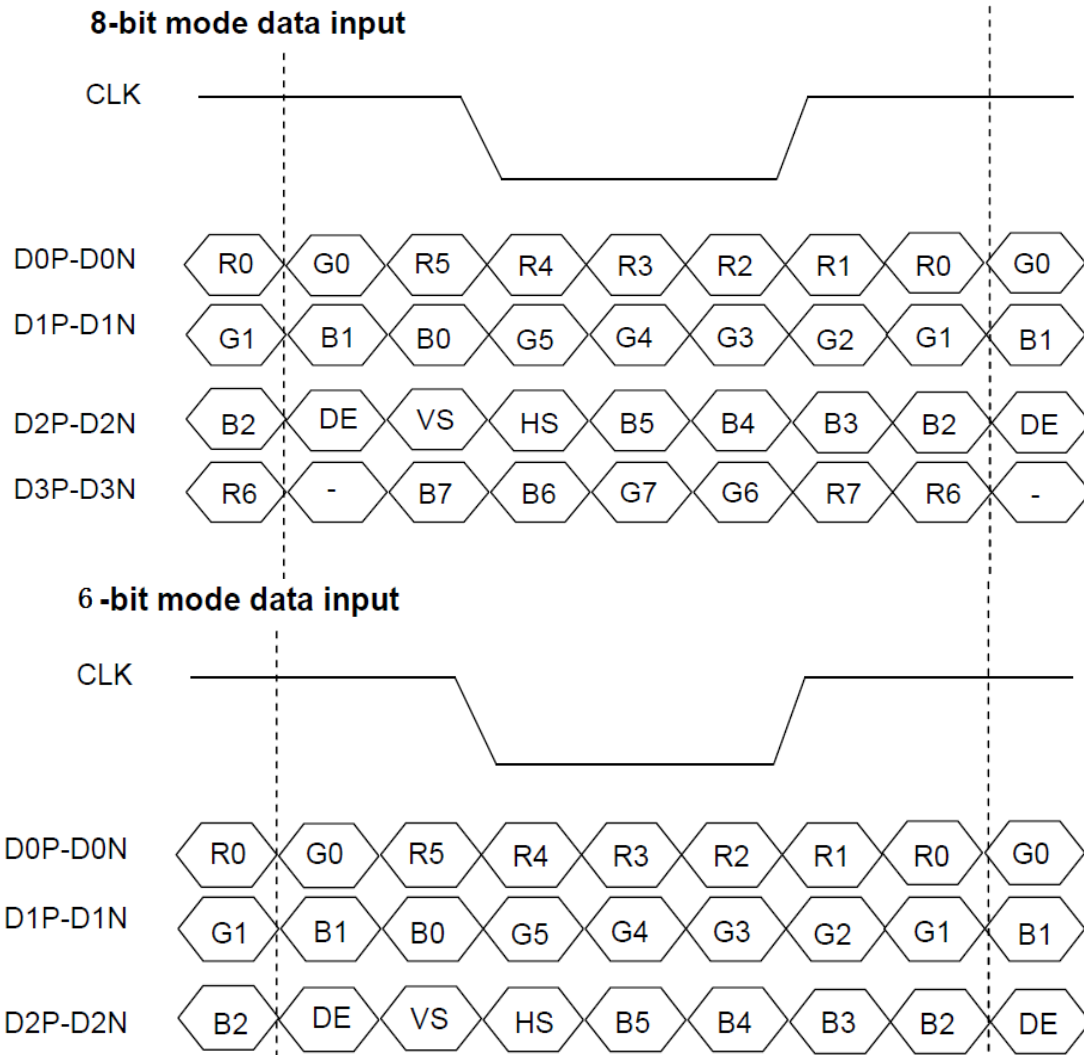

Figure 5.3 LVDS data input format (VESA standard)

Note: This LCD module supports HV mode only, so HSYNC&VSYNC signal is necessary.

5.4 Power On/Off Sequence

Item	Symbol	Min	Typ	Max	Unit	Remark
VDD on to VDD stable	Tp1	0.5	-	-	ms	
VDD stable to signal on	Tp2	50	-	-	ms	
Signal on to VLED_EN on	Tp3	200	-	-	ms	
PWM on to VLED_EN on	Tp4	0	-	-	ms	
VLED to PWM on	Tp5	10	-	-	ms	
VLED on to VELD stable	Tp6	0.5	-	10	ms	
VDD off time	Tp7	-	-	10	ms	
VDD off to next VDD on	Tp8	500	-	-	ms	
Signal off before VDD off	Tp9	0	-	50	ms	
VLED_EN off before signal off	Tp10	200	-	-	ms	
VLED_EN off before PWM off	Tp11	0	-	-	ms	
PWM off before VLED off	Tp12	10	-	-	ms	

Table 5.4 Power on/off sequence

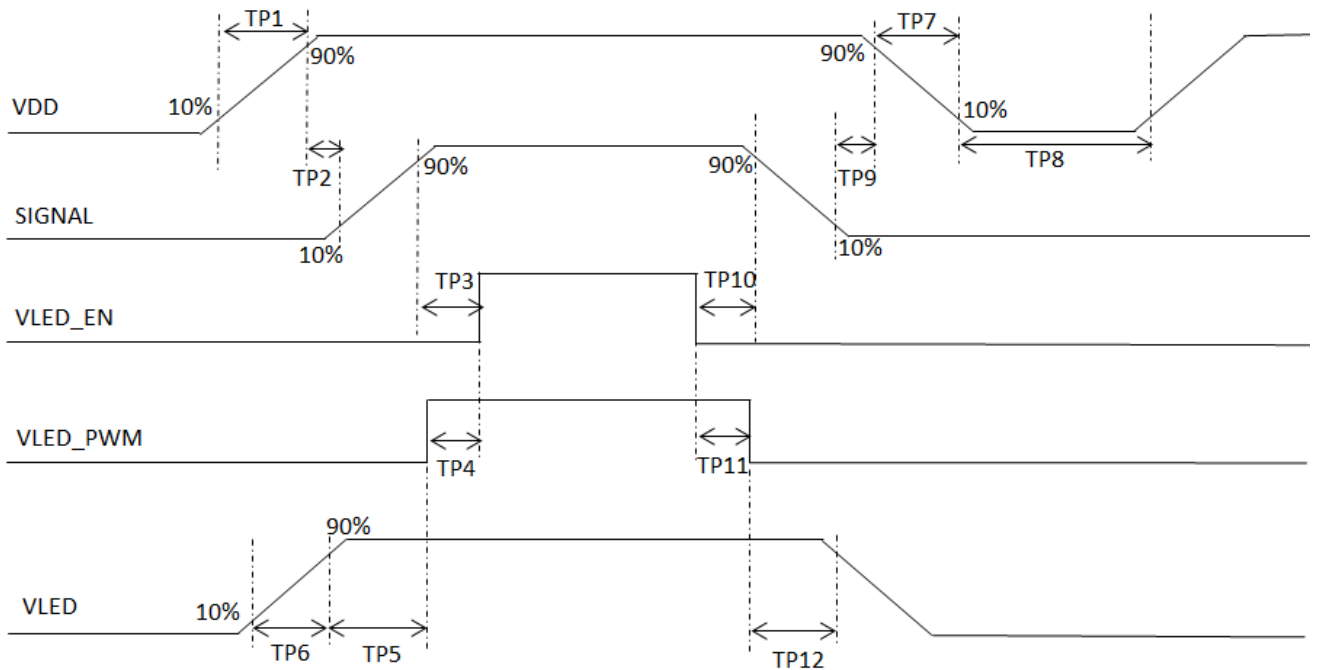

Figure 5.4 Interface power on/off sequence

Note: It is advised that backlight turned on later than display stabilized.

6 Optical Characteristics

Ta=25°C

Item	Symbol	Condition	Min	Typ	Max	Unit	Remark	
View Angles	θT	CR ≥ 10	75	85	-	Degree	Note 2	
	θB		75	85	-			
	θL		75	85	-			
	θR		75	85	-			
Contrast Ratio	CR	θ=0°	800	1000	-	-	Note1 Note3	
Response Time	T _{ON} +T _{OFF}	25°C	-	25	40	ms	Note1 Note4	
Chromaticity	White	x	Backlight is on	0.250	0.30	0.350	-	Note5 Note1
		y		0.270	0.320	0.370		
	Red	x		0.593	0.643	0.693		
		y		0.286	0.336	0.386		
	Green	x		0.253	0.303	0.353		
		y		0.571	0.621	0.671		
	Blue	x		0.096	0.146	0.196		
		y		0.032	0.082	0.132		
Uniformity	U	-	70	75	-	%	Note1 Note6	
NTSC	-	-	67	72	-	%	Note 5	
Luminance	L	-	360	450	-	cd/m ²	Note1 Note7	

Test Conditions:

1. The ambient temperature is 25±2°C. humidity is 65±7%
2. The test systems refer to Note 1 and Note 2.

Note 1: Definition of optical measurement system.

The optical characteristics should be measured in dark room. After 5 minutes operation, the optical properties are measured at the center point of the LCD screen. All input terminals LCD panel must be ground when measuring the center area of the panel.

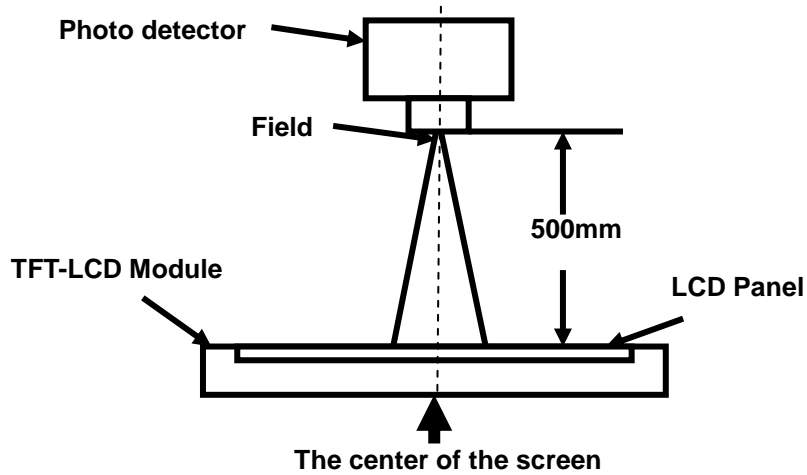

Note 2: Definition of viewing angle range and measurement system.

viewing angle is measured at the center point of the LCD by CONOSCOPE(ergo-80).

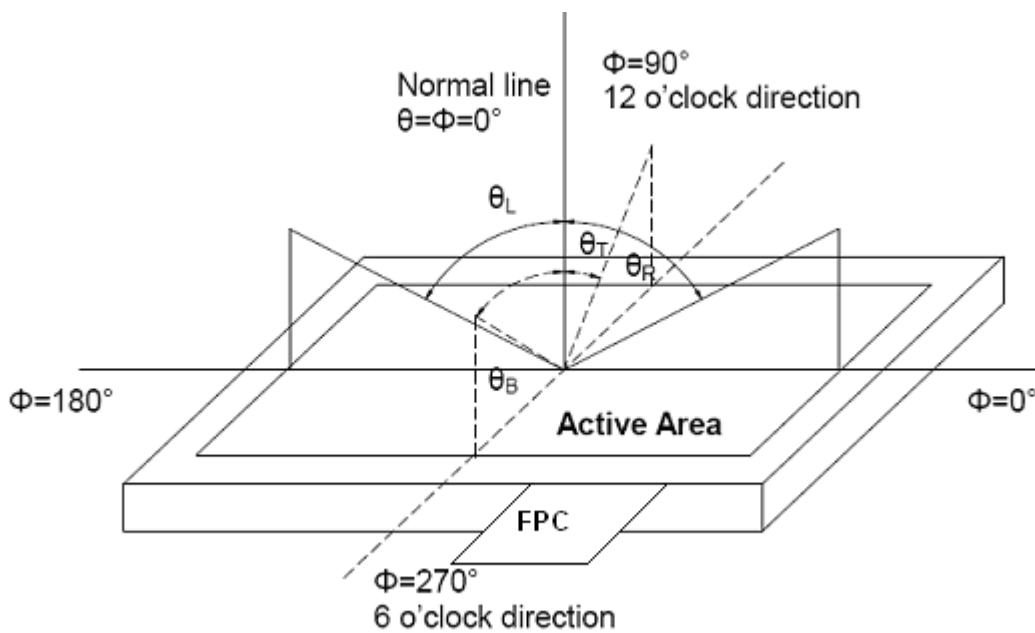

Fig. 1 Definition of viewing angle

Note 3: Definition of contrast ratio

$$\text{Contrast ratio (CR)} = \frac{\text{Luminance measured when LCD is on the "White" state}}{\text{Luminance measured when LCD is on the "Black" state}}$$

“White state”: The state is that the LCD should driven by V_{white} .

“Black state”: The state is that the LCD should driven by V_{black} .

V_{white} : To be determined V_{black} : To be determined.

Note 4: Definition of Response time

The response time is defined as the LCD optical switching time interval between “White” state and “Black” state. Rise time (T_{ON}) is the time between photo detector output intensity changed from 90% to 10%. And fall time (T_{OFF}) is the time between photo detector output intensity changed from 10% to 90%.

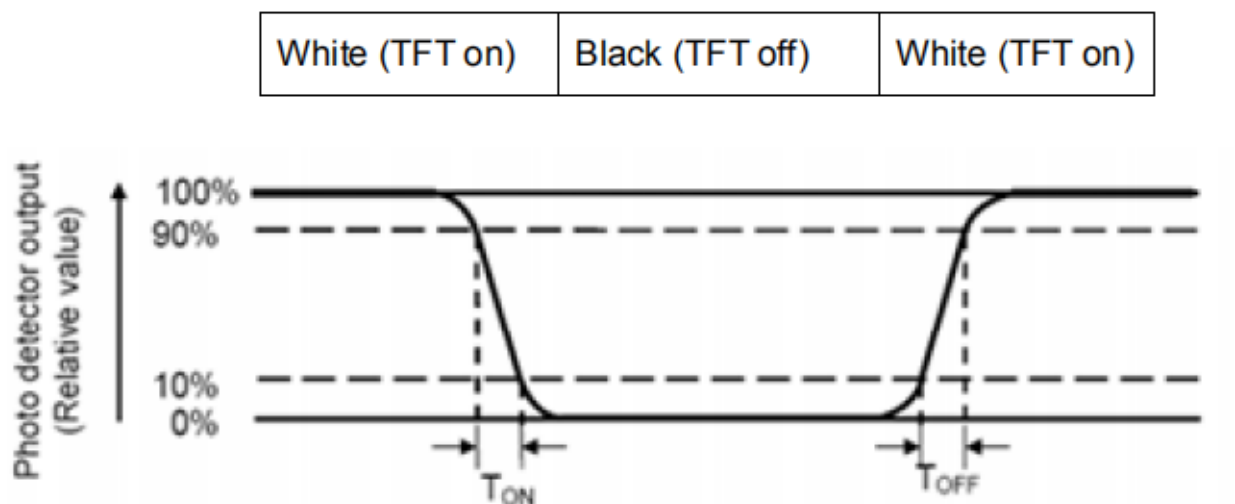

Note 5: Definition of color chromaticity (CIE1931)

Color coordinates measured at center point of LCD.

Note 6: Definition of Luminance Uniformity

Active area is divided into 9 measuring areas (Refer Fig. 2). Every measuring point is placed at the center of each measuring area.

Luminance Uniformity(U) = L_{min} / L_{max}

L-----Active area length W----- Active area width

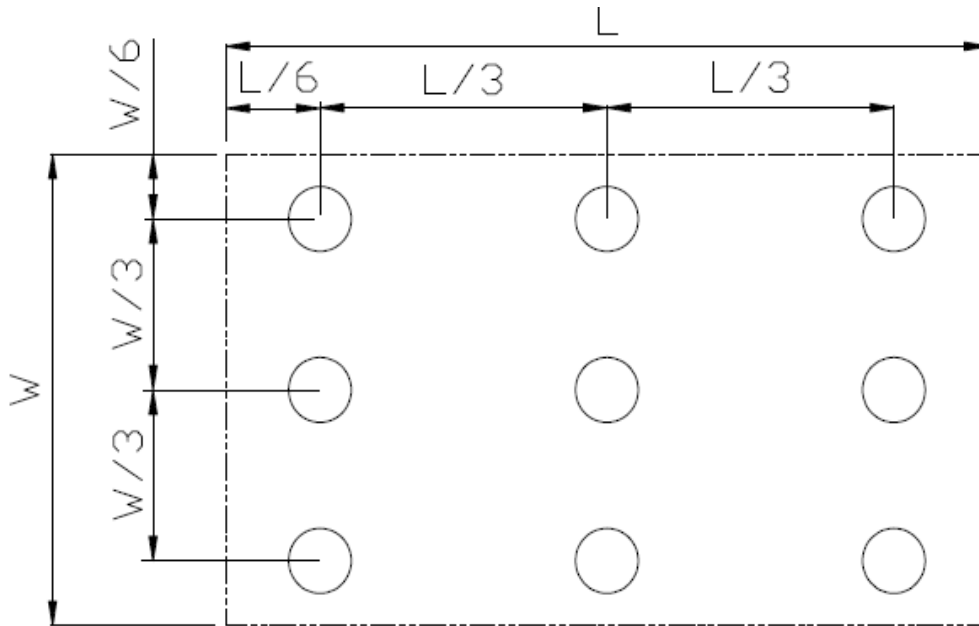

L_{max} : The measured maximum luminance of all measurement position.

L_{min} : The measured minimum luminance of all measurement position.

Note 7: Definition of Luminance :

Measure the luminance of white state at center point.

7 Environmental / Reliability Test

No	Test Item	Condition	Remark
1	High Temperature Operation	Ta=+70°C, 240hrs	(Note1) IEC60068-2-1:2007,GB2423.2-2008
2	Low Temperature Operation	Ta=-20°C, 240hrs	IEC60068-2-1:2007 GB2423.1-2008
3	High Temperature Storage (non-operation)	Ta=+80°C, 240hrs	IEC60068-2-1:2007 GB2423.2-2008
4	Low Temperature Storage (non-operation)	Ta=-30°C, 240hrs	IEC60068-2-1:2007 GB2423.1-2008
5	High Temperature & High Humidity Operation	Ta = +60°C, 90% RH max,240 hours	(Note2) IEC60068-2-78 :2001 GB/T2423.3—2006
6	Thermal Shock (non-operation)	-30°C 30 min~+80°C 30 min, Change time:5min,100cycles	Start with cold temperature, End with high temperature, IEC60068-2-14:1984,GB2423.22-2002
7	Electro Static Discharge (operation)	C=150pF,R=330Ω; Contact:±4Kv, 5times; Air: ± 8KV,5times;	IEC61000-4-2:2001 GB/T17626.2-2006
8	Vibration (non-operation)	5~100HZ,19.60m/s ² ,1min/cycle 120times Per X\Y\Z	(Note2) IEC60068-2-6:1982 GB/T2423.10—1995
9	Shock (non-operation)	60G 6ms, ±X,±Y,±Z 3 times for each direction	(Note2) IEC60068-2-27:1987 GB/T2423.5—1995
10	Package Drop Test	Height:80 cm,1 corner, 3 edges, 6 surfaces	GB/T4857.5—1992
11	Package Vibration	Frequency : 5-20-200HZ , PSD : 0.01-0.01-0.001 Total : 0.781g ² /HZ, (x/y/z each direction 30min)	GB/T4857.23-2012

Note1: Ta is the ambient temperature of sample.

Note2: When vibration/shock test, LCD module is laid down and fixed to the test equipment.

8 Mechanical Drawing

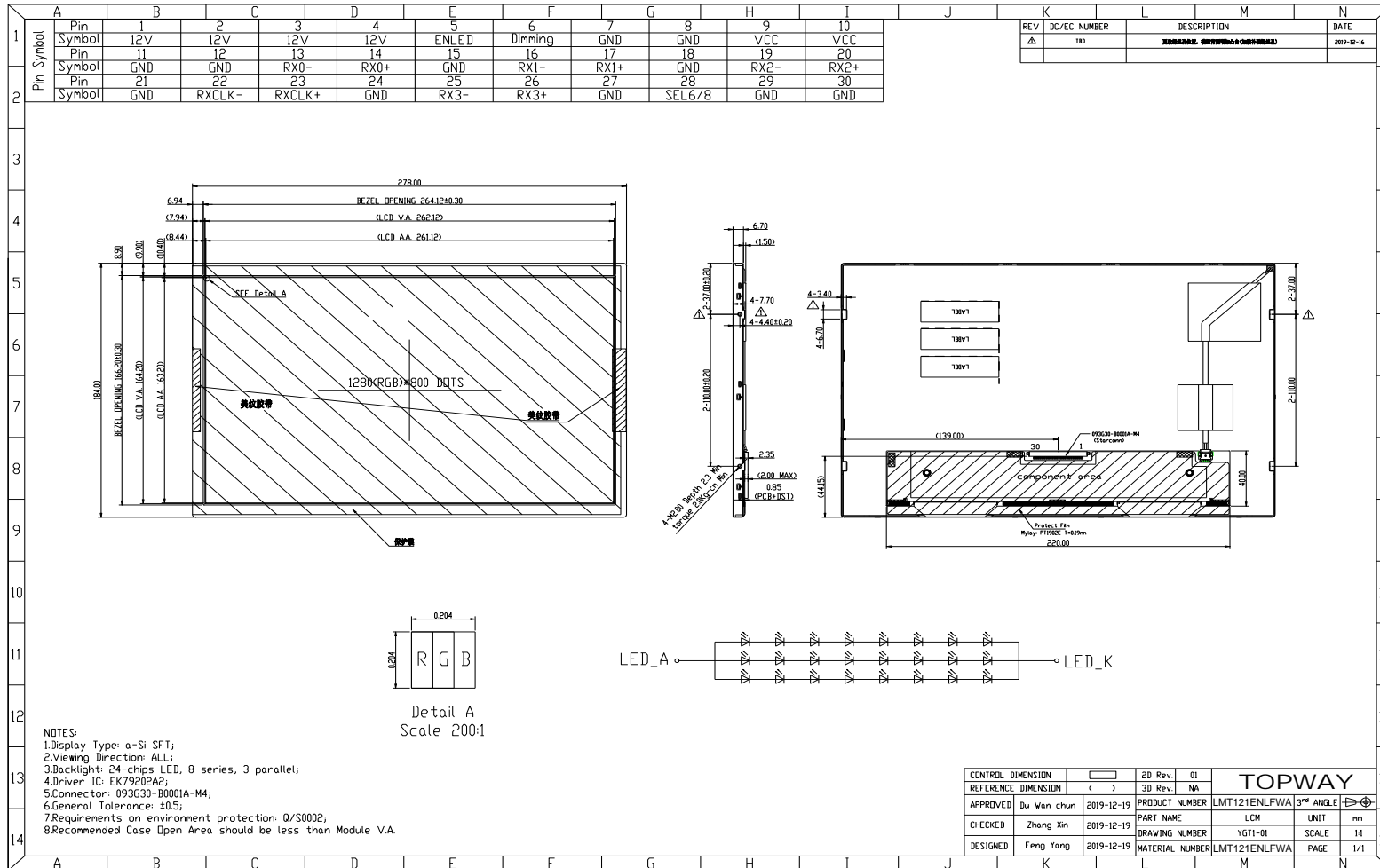

9 Precautions For Use of LCD Modules

a) Handling Precautions

- i. The display panel is made of glass. Do not subject it to a mechanical shock by dropping it from a high place, etc.
- ii. If the display panel is damaged and the liquid crystal substance inside it leaks out, be sure not to get any in your mouth, if the substance comes into contact with your skin or clothes, promptly wash it off using soap and water.
- iii. Do not apply excessive force to the display surface or the adjoining areas since this may cause the color tone to vary.
- iv. The polarizer covering the display surface of the LCD module is soft and easily scratched. Handle this polarizer carefully.
- v. If the display surface is contaminated, breathe on the surface and gently wipe it with a soft dry cloth. If still not completely clear, moisten cloth with one of the following solvents:
 - Isopropyl alcohol
 - Ethyl alcoholSolvents other than those mentioned above may damage the polarizer. Especially, do not use the following:
 - Water ,Ketone ,Aromatic solvents
- vi. Do not attempt to disassemble the LCD Module.
- vii. If the logic circuit power is off, do not apply the input signals.
- viii. To prevent destruction of the elements by static electricity, be careful to maintain an optimum work environment.
 1. Be sure to ground the body when handling the LCD Modules.
 2. Tools required for assembly, such as soldering irons, must be properly ground.
 3. To reduce the amount of static electricity generated, do not conduct assembly and other work under dry conditions.
 4. The LCD Module is coated with a film to protect the display surface. Be care when peeling off this protective film since static electricity may be generated.

b) Storage Precautions

- i. When storing the LCD modules, avoid exposure to direct sunlight or to the light of fluorescent lamps.
- ii. The LCD modules should be stored under the storage temperature range. If the LCD modules will be stored for a long time, the recommend condition is:
Temperature : 0°C ~ 40°C Relatively humidity: ≤80%
- iii. The LCD modules should be stored in the room without acid, alkali and harmful gas.

c) Transportation Precautions

The LCD modules should be no falling and violent shocking during transportation, and also should avoid excessive press, water, damp and sunshine.