



深圳市拓普微科技开发有限公司

SHENZHEN TOPWAY TECHNOLOGY CO., LTD.

LMT070ENMFWA-NND-4

LCD Module User Manual

Prepared by: Liyongzheng Date: 2025-04-08	Checked by: WangGang Date: 2025-04-14	Approved by: Date:
--	---	-----------------------------------

Rev.	Descriptions	Edit	Release Date
0.1	Preliminary release	chenzhonghua	2023-05-05
0.2	Update Instructions	Liyongzheng	2025-04-08

Table of Content

1. Applications	3
2. General Specification	3
3. Block Diagram	3
4. Terminal Function	4
4.1 K1 TFT Input Terminal	4
4.2 K2 Capacitive Touch Panel Terminal	5
5. Absolute Maximum Ratings	5
6. Electrical Characteristics	5
6.1 TFT Characteristics	5
6.2 CTP Characteristics	5
6.3 LED Backlight Circuit Characteristics	6
6.4 Power Sequence	6
7. AC Characteristics	7
7.1 TFT Timing Characteristics	7
7.2 TFT Input Clock and Data Timing Diagram	7
7.3 TFT Timing	8
7.4 TFT Data Input Format	8
7.5 CTP I2C Timing	9
7.6 CTP I2C Interface Data Structure	9
7.7 Optical Characteristics	11
8. LCD Module Design and Handling Precautions	12
9. CTP Mounting Instructions	13
9.1 Surface Mounting (Figure 1)	13
9.2 Pressure sensitive adhesive tape operation	14
Warranty	15

1. Applications

This Module is designed for portable DVD, GPS car TV & PMP(portable multimedia player) application which require high quality flat panel displays. It is also a good substitute for many outmoded CSTN module in the industrial application.
 This product is composed of a TFT-LCD panel, driver ICs, FPC ,LED backlight unit .

2. General Specification

Signal Interface :	Digital 24-bits RGB
Display Technology :	a-Si TFT active matrix
Display Mode :	Normally Back
Screen Size(Diagonal) :	7.0"
Outline Dimension :	177.5x 109.5 x 8.575 (mm) (see attached drawing for details)
Active Area :	154.21x 85.92(mm)
Number of dots :	1024x 3 (RGB) x 600
Pixel Pitch :	0.1506x 0.1432(mm)
Pixel Configuration :	RGB Stripe
Backlight :	White LED
Viewing Direction :	Full
Operating Temperature :	-20 ~ +70°C
Storage Temperature :	-30 ~ +80°C

Note:

*1. For saturated color display content (eg. pure-red, pure-green, pure-blue or pure-colors-combinations).

3. Block Diagram

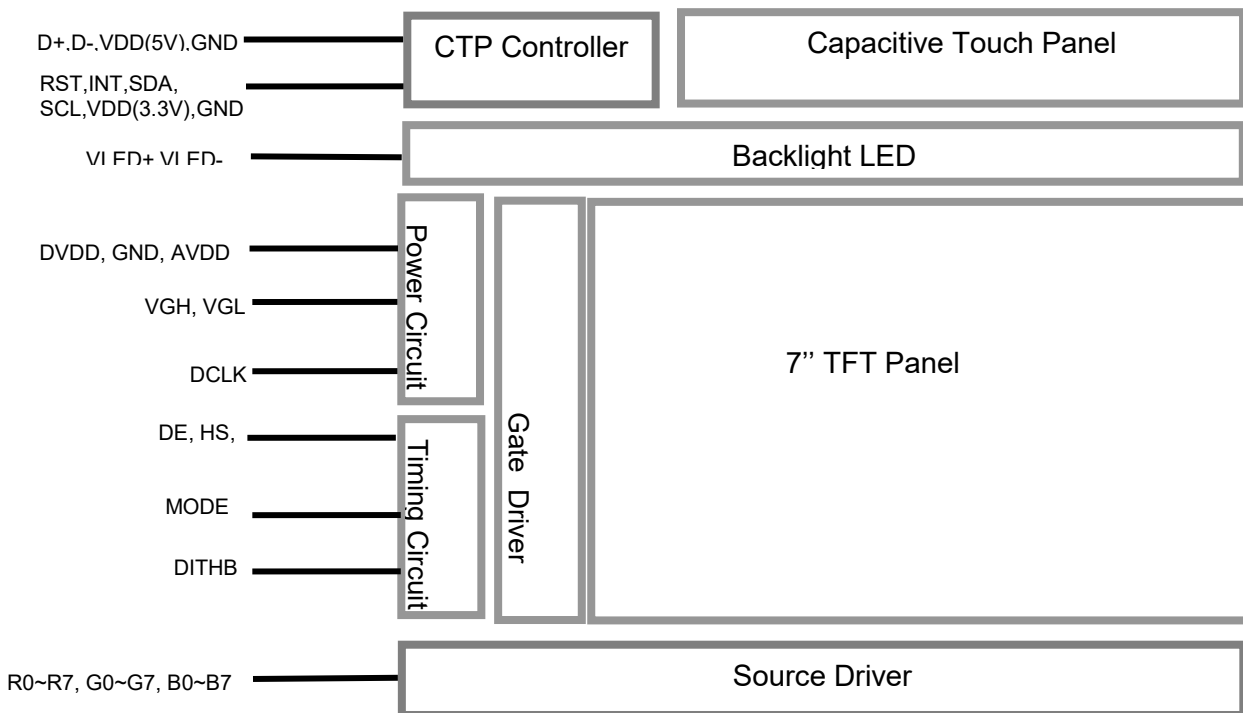

4. Terminal Function

4.1 K1 TFT Input Terminal

Pin No.	Pin Name	I/O	Descriptions
1	VLED+	Power	Positive Backlight Power Supply
2	VLED+		
3	VLED-	Power	Negative Backlight Power Supply
4	VLED-		
5	GND	Power	Power GND (0V)
6	VCOM	Input	Common voltage
7	DVDD	Power	Power for Digital Circuit
8	MODE	Input	DE/SYNC mode select (*1)
9	DE	Input	Data input enable
10	VS	Input	Vertical Sync Input
11	HS	Input	Horizontal Sync Input
12	B7	Input	8bit Data for Blue
:	:		
19	B0		
20	G7	Input	8bit Data for Green
:	:		
27	G0		
28	R7	Input	8bit Data for Red
:	:		
35	R0		
36	GND	Power	Power GND (0V)
37	DCLK	Input	Sample clock(*2)
38	GND	Power	Power GND (0V)
39	L/R	Input	Left / right selection (*3)
40	U/D	Input	Up/down selection (*3)
41	VGH	Power	Gate ON Voltage
42	VGL	Power	Gate OFF Voltage
43	AVDD	Power	Power for Analog Circuit
44	RESET	Input	Global reset pin (*4)
45	NC	-	No connection
46	VCOM	Input	Common Voltage
47	DITHB	Input	Dithering seting. L:6 bit resolution; H:8 bit resolution
48	GND	Power	Power GND (0V)
49	NC	-	No connection
50	NC		

Note:

- * 1: DE/SYNC mode select. Normally pull high.
When select DE mode, MODE="1", VS and HS must pull high.
When select SYNC mode, MODE= "0", DE must be grounded.
- * 2: Data shall be latched at the falling edge of DCLK.
- * 3: Selection of scanning mode

Setting of scan control input		Scanning direction
U/D	L/R	
GND	DVDD	Up to down, left to right
DVDD	GND	Down to up, right to left
GND	GND	Up to down, right to left
DVDD	DVDD	Down to up, left to right

*4: Global reset pin. Active low to enter reset state. Suggest to connect with an RC reset circuit for stability. Normally pull high.

4.2 K2 Capacitive Touch Panel Terminal

Pin No	Pin Name	I/O	Descriptions
1	RST	I/O	Touch Panel Reset
2	VDD3.3V	Power	I2C power supply(3.3V)
3	GND	Power	Ground(0V)
4	INT	I/O	Touch Panel INT
5	SDA	I/O	I2C DATA
6	SCL	I/O	I2C DCLK
7	GND	Power	Ground(0V)
8	D+	I/O	USB D+ signal
9	D-	I/O	USB D- signal
10	VDD(+5V)	Power	USB Power Supply(5V)

Note1: CTP Driver IC:ILI2511.

5. Absolute Maximum Ratings

Items	Symbol	Min.	Max.	Unit	Condition
Power voltage	DVDD	-0.5	5.0	V	Note1
input voltage	Vin	-0.5	5.0	V	
Operating Temperature	TOP	-20	70	°C	No Condensation
Storage Temperature	TST	-30	80	°C	No Condensation

Note:

*1: Input voltage include R0~R5, G0~G5, B0~B5, Dotclk, Hsync, Vsync, Enable, R/L, U/D.(For your reference)

*2: Ta means the ambient temperature.

It is necessary to limit the relative humidity to the specified temperature range.
Condensation on the module is not allowed.

6. Electrical Characteristics

6.1 TFT Characteristics

Items	Symbol	Min.	Typ.	Max.	Unit	Remark
Power voltage	DVDD	3.0	3.3	3.6	V	*2
	AVDD	10.8	11	11.2	V	
	VGH	19	20	21	V	
	VGL	-6.5	-6	-5.5	V	
Input signal voltage	VCOM	4.3	4.4	4.5	V	
Input logic high voltage	VIH	0.7DVDD	-	DVDD	V	*3
Input logic low voltage	VIL	0	-	0.3DVDD	V	

Note:

*1. Be sure to apply DVDD and VGL to the LCD first, and then apply VGH.

*2: DVDD setting should match the signals output voltage (refer to Note 3) of customer's system board.

*3: DCLK,HS,VS,RESET,U/D, L/R,DE,R0~R7,G0~G7,B0~B7,MODE,DITHB.

6.2 CTP Characteristics

Items	Symbol	MIN.	TYP.	MAX.	Unit	Note
Power voltage	VDD3.3V	3.0	3.3	3.5	V	
Power voltage	VDD(+5)V	4.5	5	5.5	V	
Forward Current	I_VDD3.3V	50	100	150	mA	
Forward Current	I_VDD(+5V)	50	100	150	mA	

6.3 LED Backlight Circuit Characteristics

Top=25°C

Items	Symbol	MIN.	TYP.	MAX.	Unit	Note
Forward Voltage	Vf	8.4	9.6	10.5	V	
Forward Current	If	-	180	-	mA	

Cautions:

Exceeding the recommended driving current could cause substantial damage to the backlight and shorten its lifetime.

6.4 Power Sequence

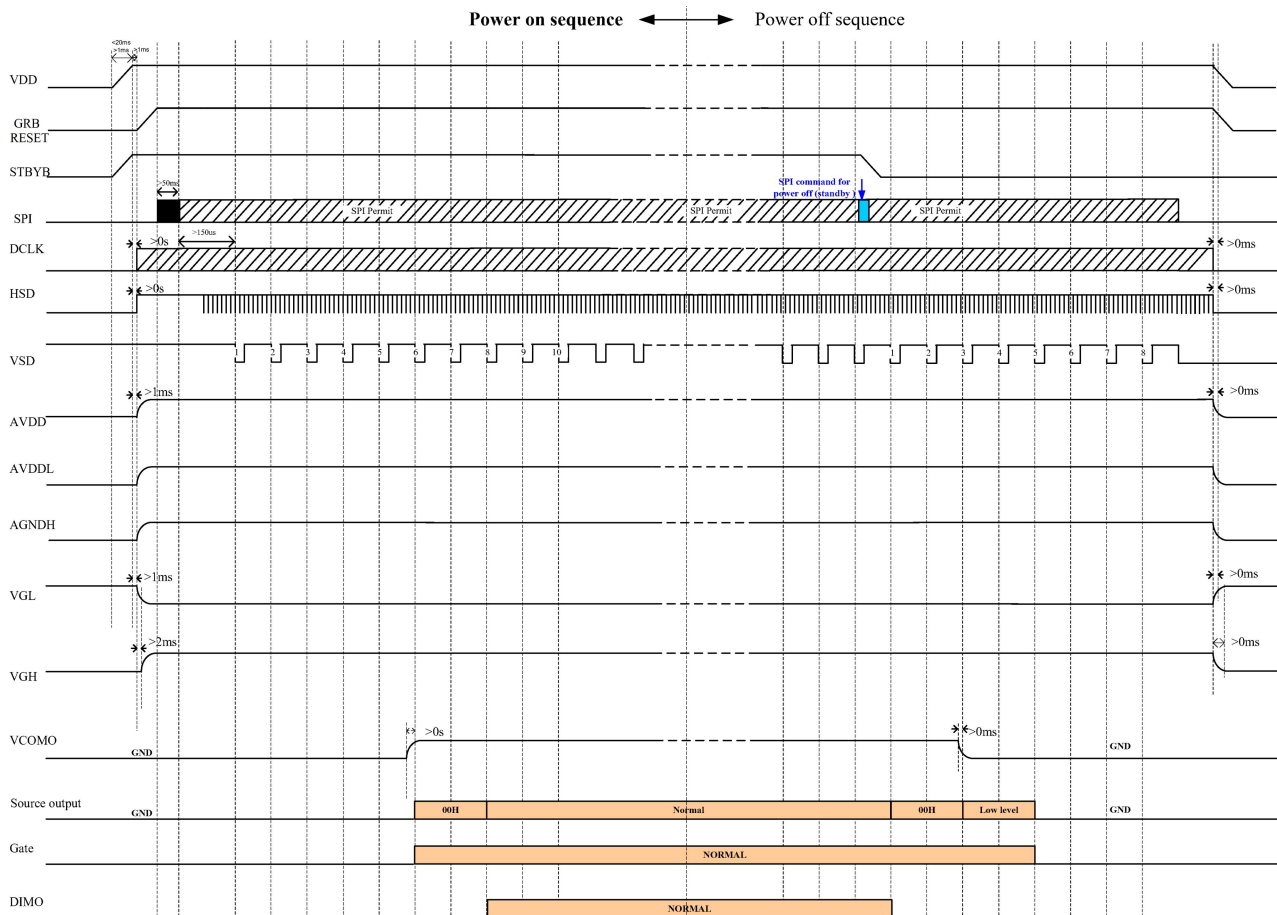

Power on:

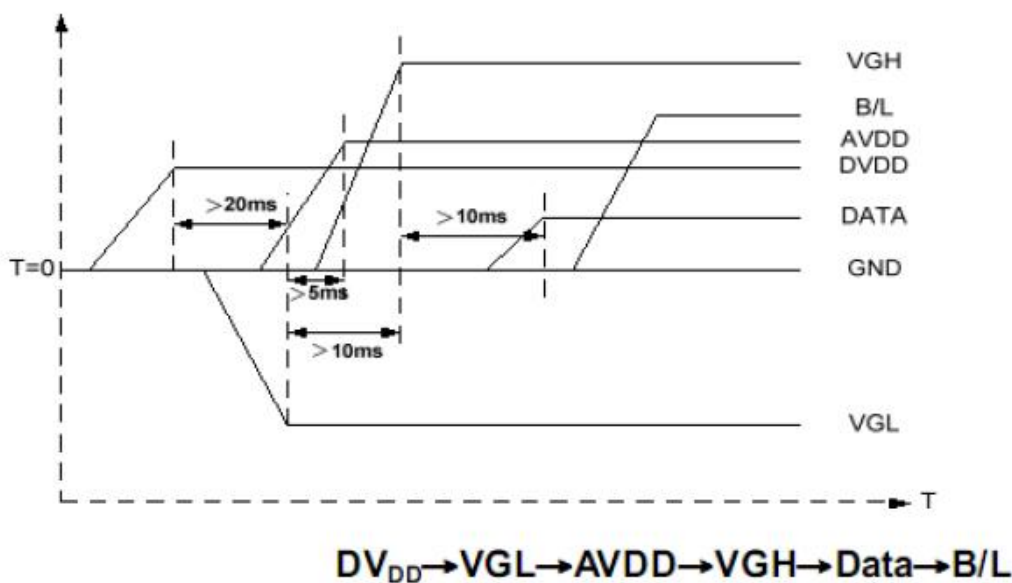

7. AC Characteristics

7.1 TFT Timing Characteristics

Item	Symbol	MIN.	TYP.	MAX.	Unit	Remark
HS setup time	Thst	5	-	-	ns	
HS hold time	Thhd	5	-	-	ns	
VS setup time	Tvst	5	-	-	ns	
VS hold time	Tvhd	5	-	-	ns	
Data setup time	Tdsu	5	-	-	ns	
Data hole time	Tdhd	5	-	-	ns	
DE setup time	Tesu	5	-	-	ns	
DVDD Power On Slew rate	TPOR	-	-	20	ms	From 0 to 90% DVDD
DCLK cycle time	Tcph	14	-	-	ns	
DCLK pulse duty	Tcwh	40	50	60	%	

Note: For the details of the timing, please see the Driver IC data sheet.

7.2 TFT Input Clock and Data Timing Diagram

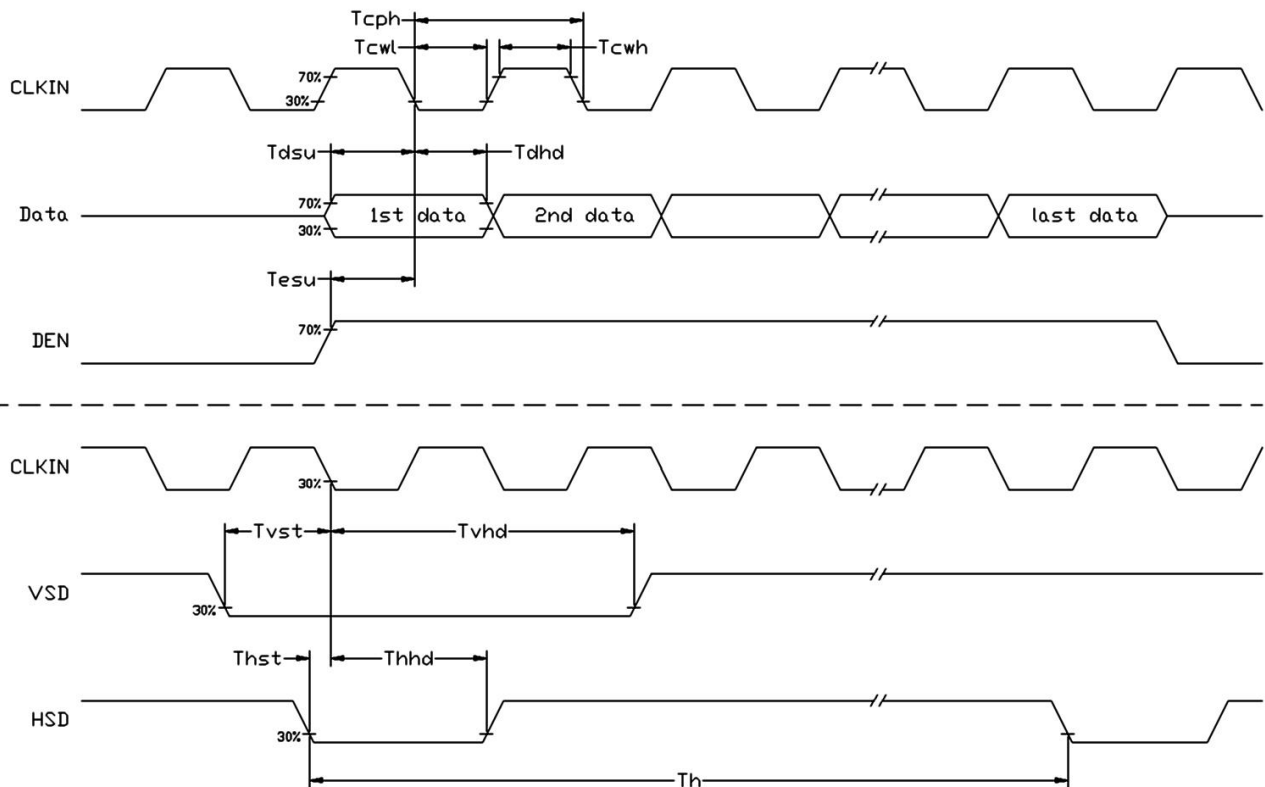

7.3 TFT Timing

Item	Symbol	MIN.	TYP.	MAX.	Unit	Remark
Clock Frequency	fclk	40.8	51.2	67.2	MHz	
Horizontal Display Area	thd	-	1024	-	DCLK	
HSD Period	th	1114	1344	1400	DCLK	
HSD Blanking	thb+thfp	90	320	376	DCLK	
Vertical Display Area	tvd	600			TH	
VSD Period	tvbp	610	635	800	TH	
VS Blanking	tvbp+tvfp	10	35	200	TH	

7.4 TFT Data Input Format

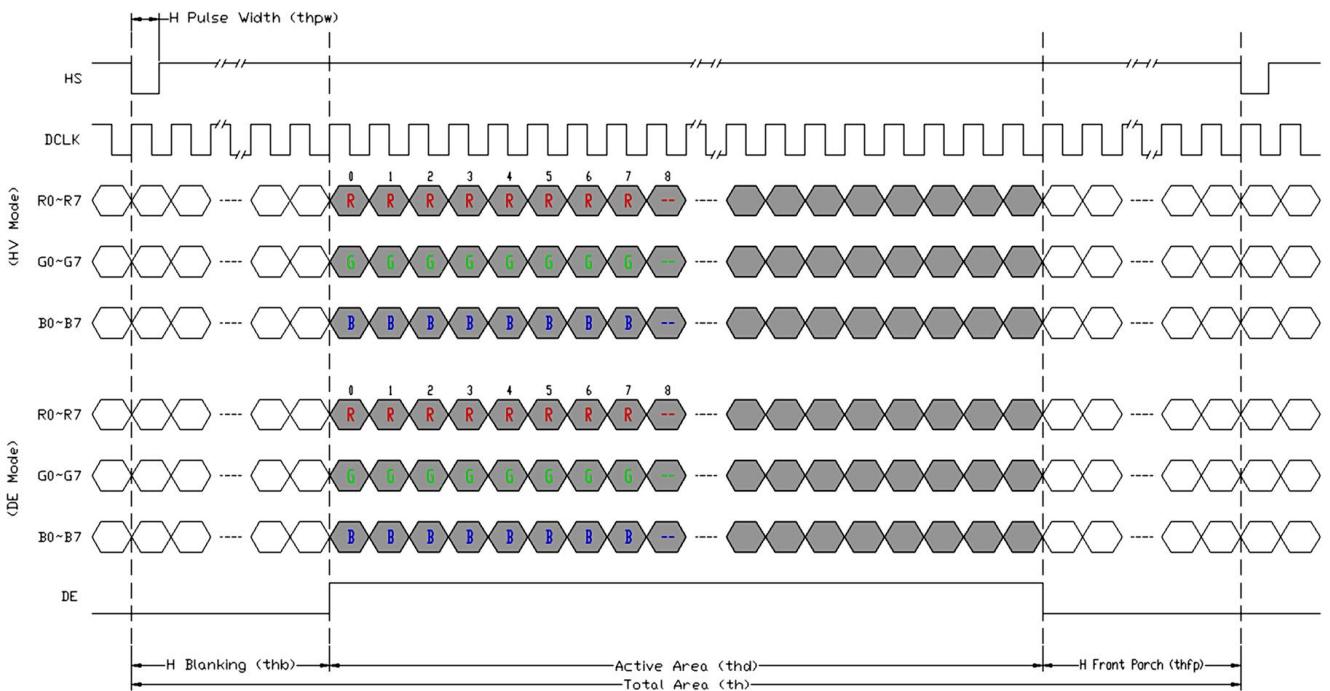

Figure 7-4-1 Horizontal input timing diagram.

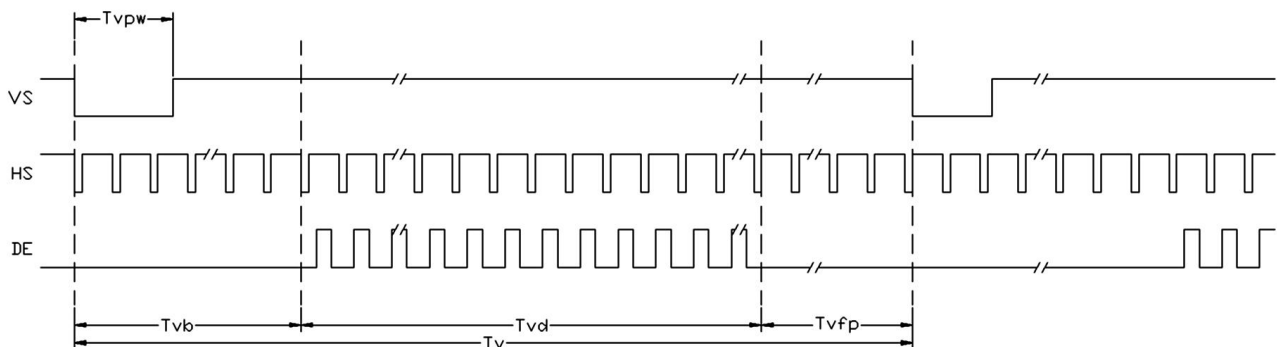
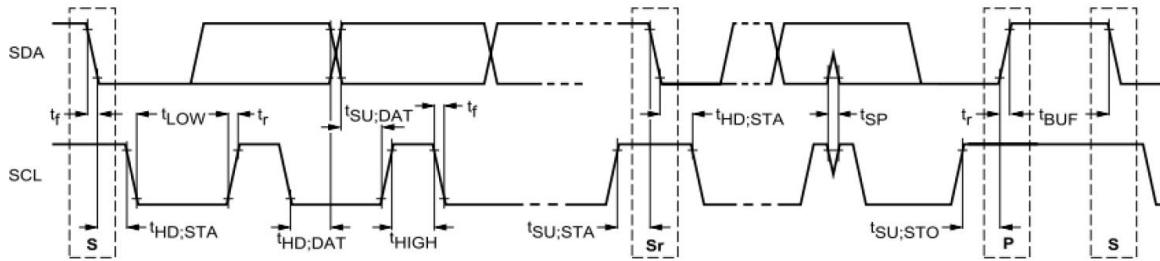

Figure 7-4-2 Vertical input timing diagram.

7.5 CTP I2C Timing



The timing of I2C Interface

Characteristics of the SDA and SCL bus lines

Symbol	Parameter	Standard mode			Fast Mode		
		Min	Max	Unit	Min	Max	Unit
f_{SCL}	SCL clock frequency	0	100	kHz	0	400	kHz
$t_{HD;STA}$	Hold time (repeated) START condition. After this period, the first clock pulse is generated	4.0	-	μs	0.6	-	μs
t_{LOW}	LOW period of the SCL clock	4.7	-	μs	1.3	-	μs
t_{HIGH}	HIGH period of the SCL clock	4.0	-	μs	0.6	-	μs
$t_{SU;STA}$	Set-up time for a repeated START condition	4.7	-	μs	0.6	-	μs
$t_{HD;DAT}$	Data hold time	5.0	-	μs	0	0.9	μs
$t_{SU;DAT}$	Data set-up time	250	-	ns	100	-	ns
t_r	Rise time of both SDA and SCL signals	-	1000	ns	-	300	ns
t_f	Fall time of both SDA and SCL signals	-	300	ns	-	300	ns
$t_{SU;STO}$	Set-up time for STOP condition	4.0	-	μs	0.6	-	μs
t_{BUF}	Bus free time between a STOP and START condition	4.7	-	μs	1.3	-	μs

7.6 CTP I2C Interface Data Structure

7.6.1 Device Address

The device addresses are 7-binary bits long and are conventionally expressed as 4 bits followed by 3 bits followed by the letter 'b', 1000 001b. These addresses occupy the high seven bits of an eight-bit field on the bus.



7-bit Device
Address: 0x41
8-bit Device Read
Address: 0x83

8-bit Device Write
Address: 0x82
I2C Device Address

7.6.2 CTP Data Transfer

Data is transferred over the I2C bus with 8-bit address and 8-bit data. The related protocol and timing diagrams are shown as below.

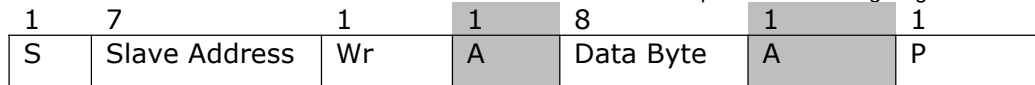

- S Start Condition
- Sr Repeated Start Condition
- Rd Read (bit value of 1)
- Wr Write (bit value of 0)
- A Acknowledge (this bit position may be '0' for an ACK or '1' for a NACK)
- P Stop Condition

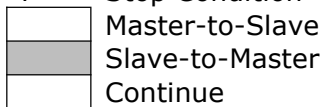

Generic Transaction Diagram

I2C Write timing

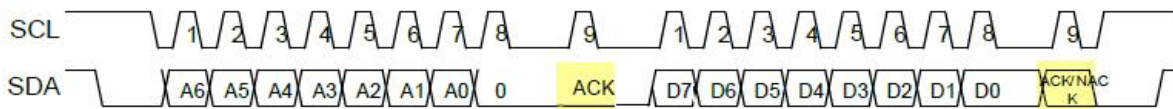

=> slave to master

I2C Read timing

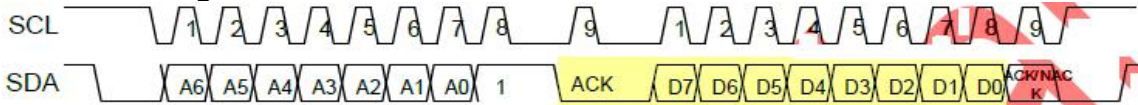

=> slave to master

Byte Write

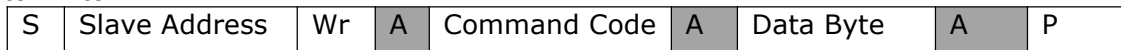

Byte Read

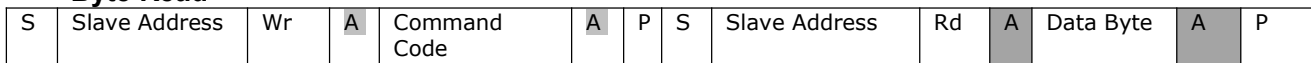

Note1: CTP Driver IC: ILI2511.

7.7 Optical Characteristics

Item	Symbol	Condition	MIN.	TYP.	MAX.	UNIT	Note.
Viewing angle	θ_L	(CR \geq 10)	70	85	-	degree	*2
	θ_R		70	85	-		
	θ_T		70	85	-		
	θ_B		70	85	-		
Response Time	T_f	Normal $\theta=0^\circ$	-	25	35	msec	*3
	T_r		-	25	35	msec	
Contrast ratio	CR		600	800	-	-	*1
Color chromaticlty	W_X		0.265	0.315	0.365	-	
	W_Y		0.265	0.315	0.365	-	
Luminance	L		-	400	-	cd/m ²	*4
Luminance uniformity	Y_U		70	75	-	%	*4

Note:

***1. Definition of Contrast Ratio**

The contrast ratio could be calculate by the following expression:

Contrast Ratio (CR) = Luminanc with all pixels white / Luminance with all pixels black

***2 Definition of Viewing Angle**

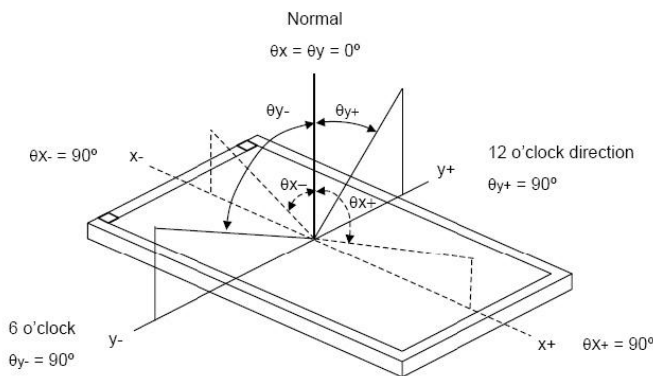

***3 Definition of response time**

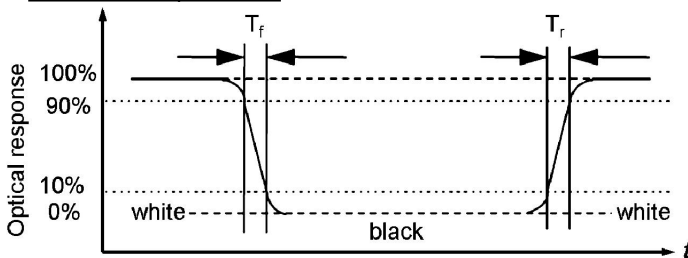

***4 Definition of Luminance Uniformity**

Luminance uniformity (Lu)=

Min. Luminance form pt1~pt9 / Max Luminance form Pt1~pt9

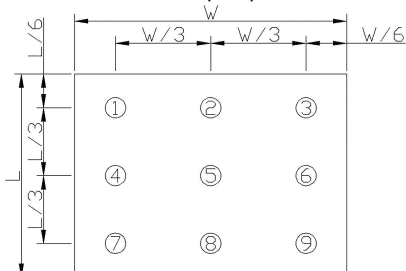

8. LCD Module Design and Handling Precautions

- Please ensure V0, VCOM is adjustable, to enable LCD module get the best contrast ratio under different temperatures, view angles and positions.
- Normally display quality should be judged under the best contrast ratio within viewable area. Unexpected display pattern may come out under abnormal contrast ratio.
- Never operate the LCD module exceed the absolute maximum ratings.
- Never apply signal to the LCD module without power supply.(No Hot-plugging)
- WARNING! Be aware of (if any) frame grounding of the LCD Module connection with the system which may cause safety issue (e.g. electric shock,etc)
- Keep signal line as short as possible to reduce external noise interference.
- IC chip (e.g. TAB or COG) is sensitive to light. Strong light might cause malfunction. Light sealing structure casing is recommended.
- Make sure there is enough space (with cushion) between case and LCD panel, to prevent external force passed on to the panel; otherwise that may cause damage to the LCD and degrade its display result.
- Avoid showing a display pattern on screen for a long time (continuous ON segment).
- LCD module reliability may be reduced by temperature shock.
- When storing and operating LCD module, avoids exposure to direct sunlight, high humidity, high or low temperature. They may damage or degrade the LCD module.
- Never leave LCD module in extreme condition (max./min storage/operate temperature) for more than 48hr.
- Recommend LCD module storage conditions is 0 C~40 C <80%RH.
- LCD module should be stored in the room without acid, alkali and harmful gas.
- Avoid dropping & violent shocking during transportation, and no excessive pressure press, moisture and sunlight.
- LCD module can be easily damaged by static electricity. Please maintain an optimum anti-static working environment to protect the LCD module. (eg. ground the soldering irons properly)
- Be sure to ground the body when handling LCD module.
- Only hold LCD module by its sides. Never hold LCD module by applying force on the heat seal or TAB.
- When soldering, control the temperature and duration avoid damaging the backlight guide or diffuser which might degrade the display result such as uneven display.
- Never let LCD module contact with corrosive liquids, which might cause damage to the backlight guide or the electric circuit of LCD module.

8. 液晶显示模块设计和使用须知

- 请注意 V0, VCOM 的设定, 以确保液晶显示模块在不同的使用温度下以及在不同的视角和位置观察模块显示, 均能达到最佳对比度, 请务必将应用电路上设置为对比度可调。
- 请注意液晶显示模块的显示品质判定是指在正常对比度下以及视窗 (V. A) 范围内进行的, 非正常对比度下液晶可能会出现非预期的显示不良, 应注意区分。
- 请勿在最大额定值以外使用液晶显示模块。
- 请勿在没有接通电源的条件下, 给液晶显示模块输送信号。(禁止热插拔)
- 警告! 使用前需评估液晶显示模块的金属框架/壳体地 (如有) 与整机关系和安全性 (如: 漏电安全性, 等)
- 请尽可能缩短信号线的连接, 以避免对液晶显示模块的信号干扰。
- 集成电路因 IC 芯片 (如 TAB 或 COG) 对紫外线极为敏感, 强光环境下可能会引起液晶显示模块功能失效, 故应采用不透光的外壳。
- 请在液晶显示模块与外壳之间保留足够的空间 (可使用衬垫), 以缓冲外力对液晶显示模块的损坏或因受力不均而产生的显示不匀等异常现象。
- 避免液晶显示屏在某一画面下长时间点亮, 否则有出现残影的风险; 请通过软件每隔一段时间改变一次画面。
- 液晶显示模块的可靠性可能因温度冲击而降低。
- 请勿在阳光直射、高湿、高温或低温下储存和使用液晶显示模块, 这将造成液晶显示模块的损坏或失效。
- 请勿在极限环境 (最大/最小存储/工作温度) 下使用或放置液晶显示模块超过 48 小时以上。
- 液晶显示模块建议存储条件为: 0 C~40 C <80%RH。
- 请勿让液晶显示模块存储于带有 酸性, 碱性, 有害气体环境之中。
- 在运输过程中, 请勿让液晶显示模块跌落与猛烈震动, 同时避免 异常挤压, 高湿度, 与阳光照射。
- 液晶显示模块极易受静电损坏, 请务必保证液晶显示模块在防静电的工作环境中使用或保存。(如: 烙铁正确接地, 等)
- 拿取液晶显示模块时需注意操作人员的接地情况。
- 请手持液晶显示模块的边沿取放模块, 防止热压纸或 TAB 部位受力。
- 焊接液晶模块时, 请注意控制烙铁的温度、焊接时间, 以免烫坏导光板或偏光片, 导致显示不匀等不良现象发生。
- 请勿使用洗板水等腐蚀性液体接触液晶模块, 以免腐蚀导光板或模块电路。

- Only clean LCD with a soft dry cloth, Isopropyl Alcohol or Ethyl Alcohol. Other solvents (e.g. water) may damage the LCD.
- Never add force to components of LCD module. It may cause invisible damage or degrade the module's reliability.
- When mounting LCD module, please make sure it is free from twisting, warping and bending.
- Do not add excessive force on surface of LCD, which may cause the display color change abnormally.
- LCD panel is made with glass. Any mechanical shock (e.g. dropping from high place) will damage the LCD module.
- Protective film is attached on LCD screen. Be careful when peeling off this protective film, since static electricity may be generated.
- Polarizer on LCD gets scratched easily. If possible, do not remove LCD protective film until the last step of installation.
- When peeling off protective film from LCD, static charge may cause abnormal display pattern. The symptom is normal, and it will turn back to normal in a short while.
- LCD panel has sharp edges, please handle with care.
- Never attempt to disassemble or rework LCD module.
- If display panel is damaged and liquid crystal substance leaks out, be sure not to get any in your mouth, if the substance comes into contact with your skin or clothes promptly wash it off using soap and water.

- 仅可使用柔软的干布，异丙醇或乙醇清洁液晶屏表面，其他任何溶剂(如:水)都有可能损坏液晶模块。
- 请勿挤压液晶显示模块上的元器件，以避免产生潜在的损坏或失效而影响产品可靠性。
- 装配液晶显示模块时，请务必注意避免液晶显示模块的扭曲或变形。
- 请勿挤压液晶显示屏表面，这将导致显示颜色的异常。
- 液晶屏由玻璃制作而成，任何机械碰撞(如从高处跌落)均有可能损坏液晶显示模块。
- 液晶屏表面带有保护膜，揭除保护膜时需要注意可能产生的静电。
- 因液晶显示屏表面的偏光片极易划伤，安装完成之前请尽量不要揭下保护膜。
- 请缓慢揭除保护膜，在此过程中液晶显示屏上可能会产生静电，此为正常情况，可在短时间内消失
- 请注意避免被液晶显示屏的边缘割伤。
- 请不要试图拆卸或改造液晶显示模块。
- 当液晶显示屏出现破裂，内部液晶液体可能流出；相关液体不可吞吃，绝对不可接触嘴巴，如接触到皮肤或衣服，请使用肥皂与清水彻底清洗。

9. CTP Mounting Instructions

9.1 Surface Mounting (Figure 1)

- As the CTP assembling on the countersink area with double side adhesive. The countersink area should be flat and clean to ensure the double side adhesive installation result.
- The Bezel is recommend to keep a gap ($\geq 0.3\text{mm}$ each side) around the cover lens for tolerance.
- It is recommended to provide an additional support bracket with gasket for backside support when necessary (e.g. TFT module without mounding structure). They should only provide appropriate support and keep the module in place.
- The mounting structure should be strong enough to prevent external uneven force or twist act onto the module

9. 电容触摸屏安装指导

9.1 嵌入安装（附图 1）

- 客户面框应具有使用双面胶粘贴 CTP 的结构沉台面，其粘贴面要求平整且洁净无污以保证粘贴牢靠。
- 考虑到制作误差，建议面框与 CTP 盖板之间四周留有 $\geq 0.3\text{mm}$ 间隙。
- 建议必要时在背面提供垫有胶垫附加支架(例如无安装结构的 TFT 模块)，应仅利用适当支撑以保持模块位置。
- 安装结构应具有足够的强度，以防止外部不均匀力或扭曲力作用到模块上。

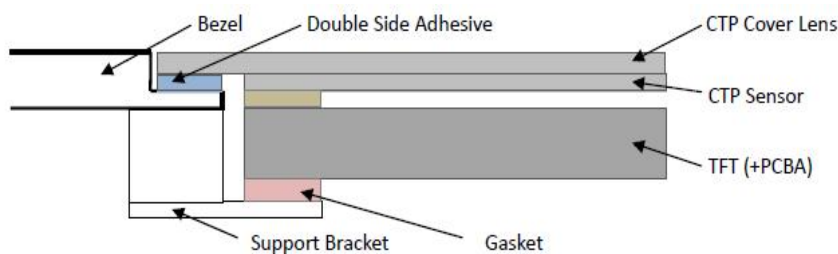

Figure 1

9.2 Pressure sensitive adhesive tape operation

- For maximum bond strength, the surfaces should be flat and thoroughly cleaned.
- 50:50 mixture of isopropyl alcohol and water is suggested.
- Let dry before taping.
- Ideal tape application is accomplished when temperature is between 21° C and 38°C. Initial tape application to surfaces at temperatures below 10°C is not recommended.
- Alignment jig should be applied for objects alignment
- Pressing jig surface should be fine enough to prevent uneven pressure onto the display module.
- General initial tape application pressure is 15PSI (0.1N/mm²) for 5~10sec (operating pressure can be calculated with the tape surface area)
- The bond is allowed to dwell 72 hr (100% bond typical build). (note: 20min about 50%; 1hr about 70%; 24hr about 90%)
- Consult manufacturer's directions for use and precautions when using cleaning solvents.

9.2 压敏胶带贴合

- 为达到最佳贴合效果, 被贴物应为平整, 无翘曲, 无凸点等; 并需完全清洁干净, 无灰尘, 无油污, 无残留物等。
- 建议用异丙醇和水的 50:50 混合液清洁, 或先用脱脂剂, 后用异丙醇和水的 50:50 混合液。
- 表面干透后才可进行贴合。
- 理想作业环境温度为 21°C~38°C。
- 不建议在 10°C 或以下的环境温度下作业。
- 撕去离型纸后应尽早贴合, 避免污染胶带表面。
- 建议使用治具定位, 一次贴正。(二次贴合可能会影响效果) 初压治具需要注意平整, 避免压破模块或产生变形。
- 一般初压时用不小于 15PSI (0.1N/mm²) 的压力并保持 5~10 秒 (请使用胶带面积运算实际组装所需压力)。
- 初压后一般需在常温下静置 (避免受力) 72hr 以达到最佳贴合效果 (100%)。
- (注: 20min 约 50%; 1hr 约 70%; 24hr 约 90%)
- 详细请参阅胶带供应商的使用说明与清洁建议

Warranty

This product has been manufactured to our company's specifications as a part for use in your company's general electronic products. It is guaranteed to perform according to delivery specifications. For any other use apart from general electronic equipment, we cannot take responsibility if the product is used in medical devices, nuclear power control equipment, aerospace equipment, fire and security systems, or any other applications in which there is a direct risk to human life and where extremely high levels of reliability are required. If the product is to be used in any of the above applications, we will need to enter into a separate product liability agreement.

- We cannot accept responsibility for any defect, which may arise from additional manufacturing of the product (including disassembly and reassembly), after product delivery.
- We cannot accept responsibility for any defect, which may arise after the application of strong external force to the product.
- We cannot accept responsibility for any defect, which may arise due to the application of static electricity after the product has passed our company's acceptance inspection procedures.
- When the product is in CCFL models, CCFL service life and brightness will vary according to the performance of the inverter used, leaks, etc. We cannot accept responsibility for product performance, reliability, or defect, which may arise.
- We cannot accept responsibility for intellectual property of a third part, which may arise through the application of our product to our assembly with exception to those issues relating directly to the structure or method of manufacturing of our product.

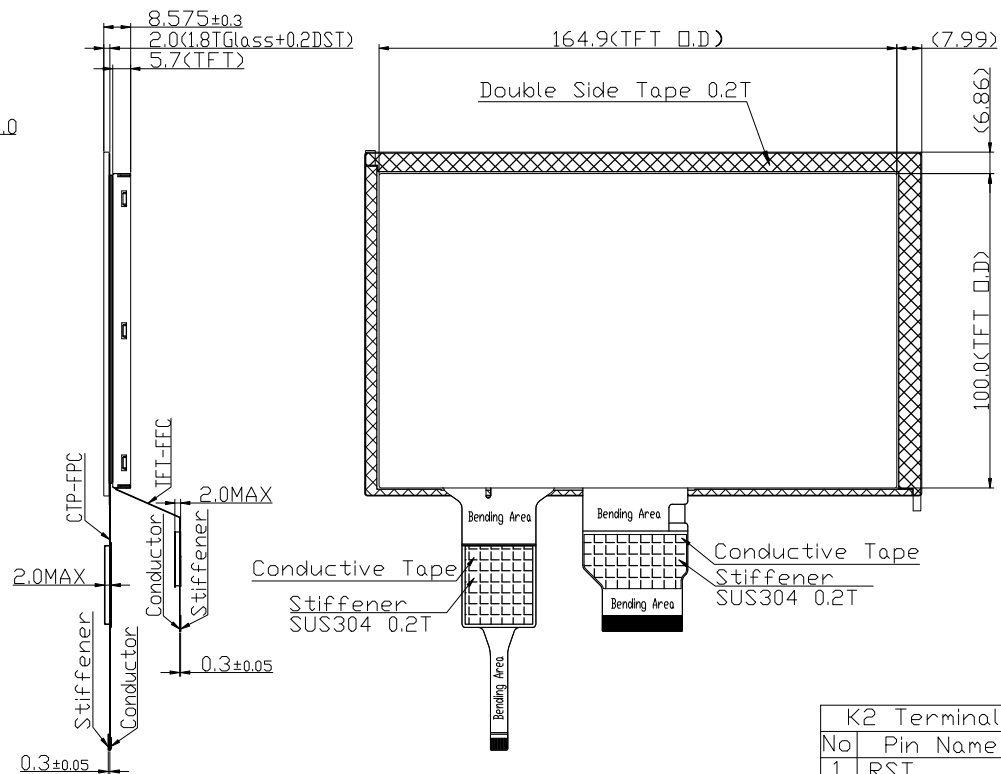
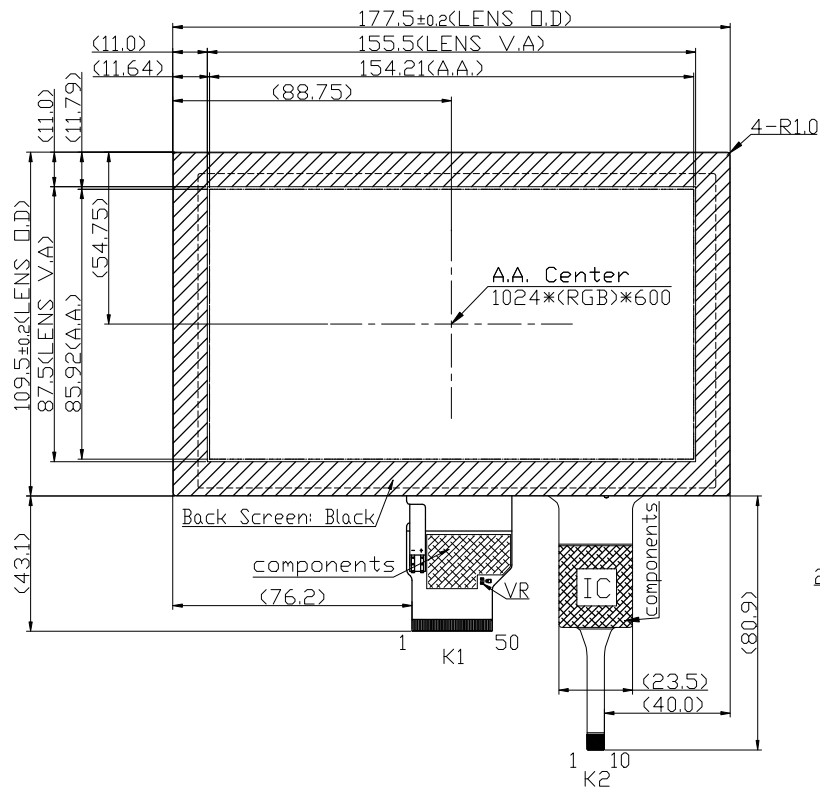

K1 Terminal

No	Pin Name
1	VLED+
2	VLED+
3	VLED-
4	VLED-
5	GND
6	VCOM
7	DVDD
8	MODE
9	DE
10	VS
11	HS
12	B7
:	:
19	B0
20	G7
:	:
27	G0
28	R7
:	:
35	R0
36	GND
37	DCLK
38	GND
39	L/R
40	U/D
41	VGH
42	VGL
43	AVDD
44	RESET
45	NC
46	VCOM
47	DITHB
48	GND
49	NC
50	NC

K2 Terminal

No	Pin Name
1	RST
2	VDD(3.3V)
3	GND
4	INT
5	SDA
6	SCL
7	GND
8	D+
9	D-
10	VDD(+5V)

Note:

- *1. LCD Display Type: TFT.Transmissive (Full View)
- *2. Pixel Arrangement: RGB-STRIPE
- *3. Color Depth : 16.7M Colors
- *4. Operating Voltage(TFT) : 3.3V
Operating Voltage(CTP) : 3.3V(IIC) / 5.0V(USB)
- *5. Backlight: White LED
- *6. Backlight Supply: 180mA(Constant Current 9.6V TYP.)
- *7. Interface :
K1 RGB_24bit (P0.5x50pin FFC Socket or equivalent)
K2 IIC/USB (P0.5x10pin FFC Socket or equivalent)
- *8. Operating Temperature : $-20^{\circ}\text{C} \sim 70^{\circ}\text{C}$
- *9. Storage Temperature : $-30^{\circ}\text{C} \sim 80^{\circ}\text{C}$
- *10. Touch Panel Type : Capacitive Touch Panel
- *11. Unmarked Tolerance : $\leq 150, \pm 0.3$; $> 150, \pm 0.5$

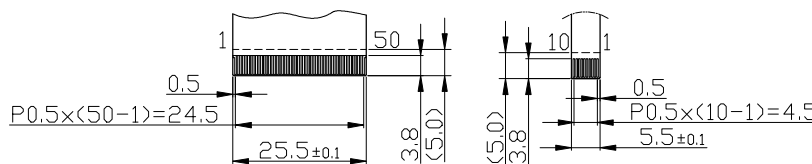

K1 Details
Scale=1/1

K2 Details
Scale=1/1

C		
B		
A		
Rev	Note	Date
Dwg	Title	
LMT070ENMFWA-NND-4 Outline Dwg		
Dwg No.	MK-007956-1-1	Date
		2022-12-29
Scale	Tol.	Unit
9/10		mm
Approved	Checked	Paper Size
		A3
		Drawn
		Zhangwenbo

TOPWAY